



**Ford E-450 Dual Rear Wheel Cutaway
Liquid Propane Autogas Fuel System – Aft-axle**

Installation Instructions

CONTENTS

C With vehicle lowered

- 8. Installing New Fuel Fill System and Fuel Filter
- 9. Preparing Engine Compartment
- 12. Installing New Fuel Rails
- 14. Installing Fuel Rail Pressure Control Module
- 16. Installing Smart Relay Module and Auxiliary Fuse Box Bracket
- 17. Installing Instrument Panel Wiring Harness
- 18. Installing Underhood Wiring Harness

E With vehicle lowered

- 24. Installing Badges and Labels and Completing the Kit Installation
- 25. ROUSH CleanTech Badge Installation

A Vehicle positioned in stall

- 1. Removing the Powertrain Control Module
Sending the PCM for Reprogramming

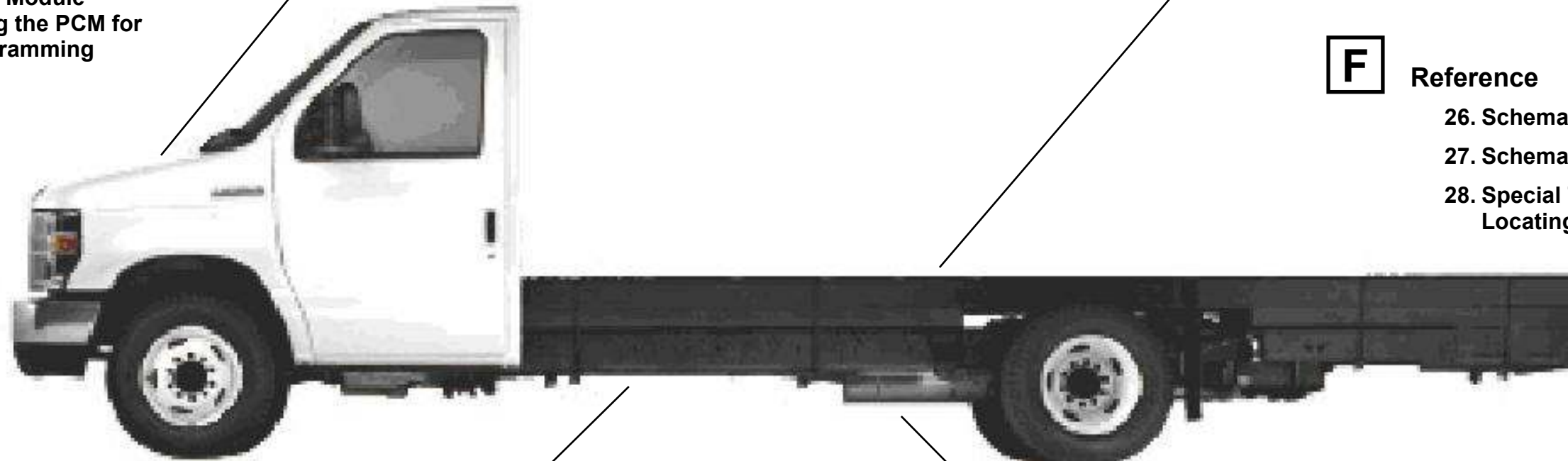

F Reference

- 26. Schematic — ROUSH Fuel System
- 27. Schematic — ROUSH Wiring Harness
- 28. Special Tools and Fuel Filter Bracket Locating Templates

B With vehicle raised

- 2. Removing Original Fuel Tank
- 3. Removing Original Rear Fuel and Vapor Lines
- 4. Removing Original Forward Fuel Supply Line
Removing Original Filler Pipe
- 5. Installing New Forward Fuel Lines
- 6. Preparing the Frame
- 7. Installing New Rear Fuel Lines and Flex Couplings

D With vehicle raised

- 19. Installing Rear Frame Wiring Harness
- 20. Plugging Vapor Canister Port and Sealing FTPT Connector
- 21. Preparing the Tank
- 22. Installing New Fuel Tank
- 23. Installing Fuel Fill Line, Tank-to-Filter

REMOVING THE POWERTRAIN CONTROL MODULE

1. Using a scan tool, check for all error codes. Correct all errors before continuing.
2. Remove upper radiator shroud (cover) for tool access. Remove air cleaner inlet assembly, disconnect mass air flow (MAF) sensor connector and remove air cleaner cover.
3. Remove the powertrain control module (PCM) following the procedure in the *Ford Workshop Manual, Section 303-14, Electronic Engine Controls*. Keep all fasteners for reuse.
4. Depressurize the fuel rail using the procedure described in the *Ford Workshop Manual, Section 310-00 Fuel System, General Information*.
5. Disconnect and remove the battery from the vehicle.
6. From inside the passenger compartment, remove the engine cover.
7. Install the hang tag label onto the rear view mirror of the vehicle.

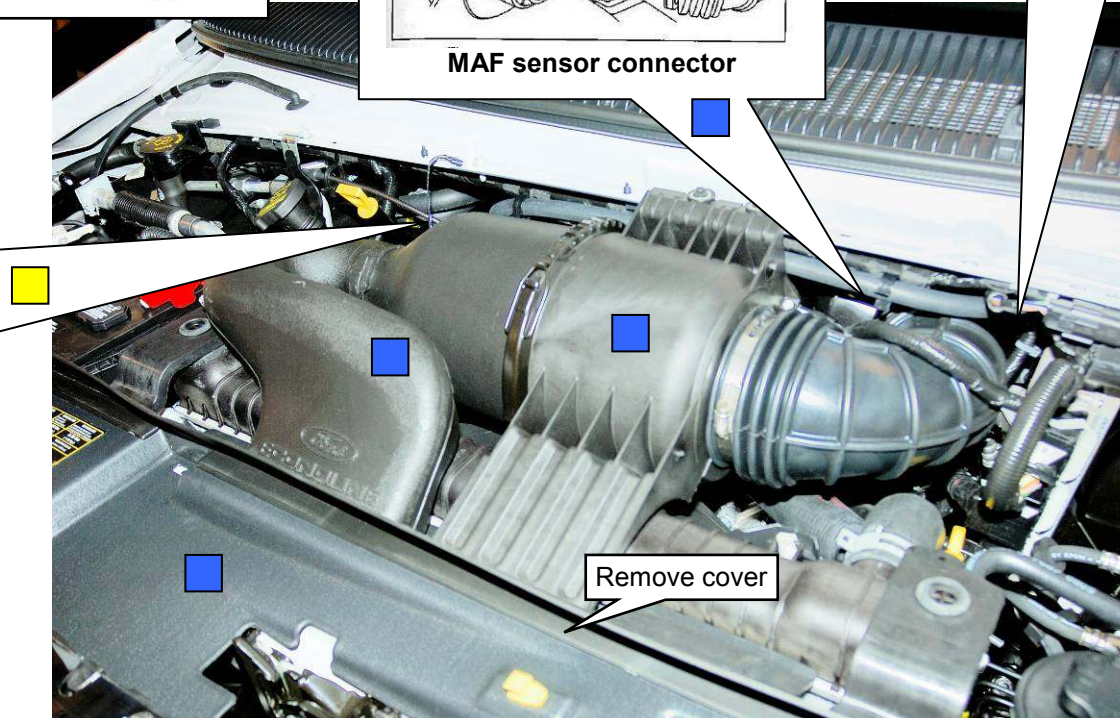
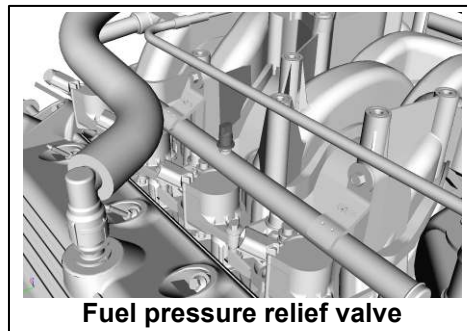
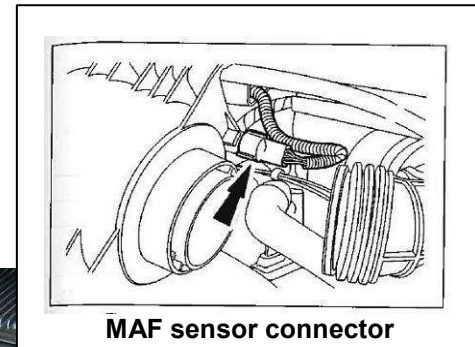
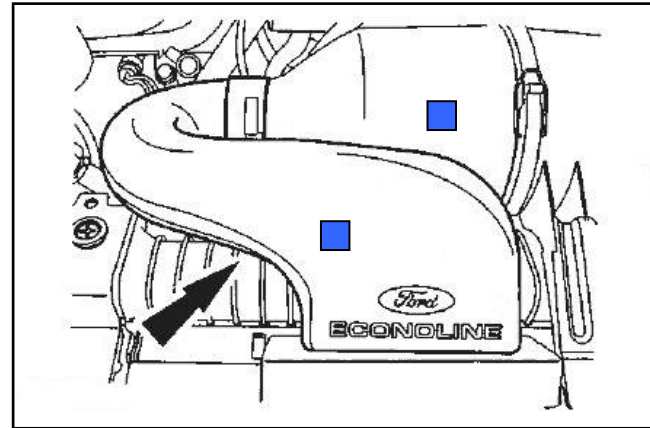
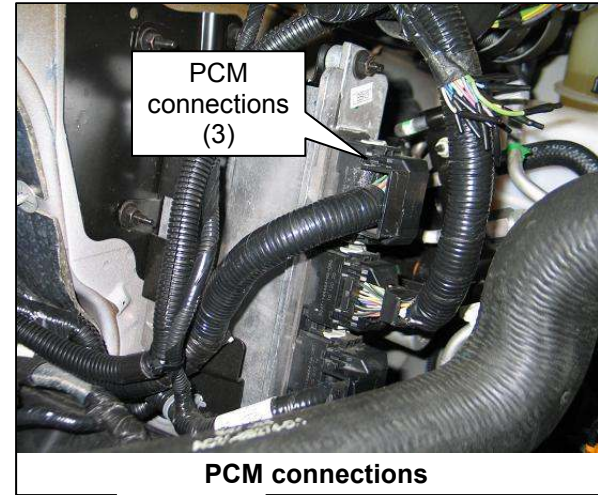

SENDING THE PCM FOR REPROGRAMMING

ROUSH CLEANTECH
E-450 PROPANE PCM LABEL

Purchaser's Full Name _____
 Purchaser's Address _____
 Vehicle Model Year _____ Mileage at Installation _____
 Vehicle Test Group _____
 Vehicle Identification Number _____
 Hang Tag Installed
(Must be marked for PCM to be tested)
 GVWR Front _____
 GVWR Rear _____
 Propane Fuel Tank Serial Number _____

P8C2-9A095-DB

Ford Motor Company
IMPORTANT ENGINE INFORMATION/
VEHICLE EMISSION CONTROL INFORMATION

Conforms to regulations: 2009 MY Incomplete

U.S. EPA: HDE* OBD: HD Fuel: Gasoline
California: HDE* OBD: EMD Fuel: Gasoline
*** FOR USE ONLY IN HDV WITH GVWR ABOVE 14,000#.**

Fuel Tank Capacity: 55 gal max. Persons wishing to add fuel tank capacity beyond the maximum must meet the requirements of 40CFR 86.095-35 (g)(2).

TWC/HO2S/SFI No adjustments needed. ⚠

SAMPLE 6.8L - Group: 9FMXE06.8BWX
 Evap: 9FMXF0265NAT

8. Write the requested information, including the gross vehicle weight rating (GVWR), on the PCM Return Label (P10C2-9A095-E). The test group information will be found on the original vehicle emissions control information (VECI) label (example: 6.8L – Group: 9FMXE06.8BWX). The propane fuel tank serial number can be found on the raised serial badge welded to the side of the tank. Once all information has been completed, apply the label to the back side of the PCM.

Note: Do NOT alter or remove the original VECI label from the vehicle. This label is required by law. Failure to heed this notice may void all warranties.

9. Pack the PCM securely in the shipping box (P10C2-SB-AA) provided. Enter your name and address in the **FROM** area of the shipping label provided and apply the label to the box.
10. Call for a **FedEx package pickup**. Dial **1-800-463-3339**, then **0**, and **speak to an agent in person**. Do NOT use the automated option to schedule a pickup.

FedEx will deliver the package to ROUSH CleanTech via overnight service. ROUSH CleanTech will reprogram the PCM during the day in which it is received and return it to you via overnight service.

Included with the returned newly flashed PCM will be a ROUSH CleanTech VECI label and supplemental instructions for installing the new VECI label.

Note: ROUSH CleanTech Certified Installers who are authorized to perform on-site PCM flashing should consult the appropriate training materials for proper VECI label selection and disposition. Failure to properly follow the training guidelines could result in non-conformance to federal and local regulations.

REMOVING ORIGINAL FUEL TANK

Refer to the *Ford Workshop Manual, Section 310-01, Fuel Tank and Lines*, for instructions on removing the original fuel tank.

Note: Remove only the fuel lines, do NOT remove the brake lines when following the *Ford Workshop Manual* procedure.

1. Disconnect vapor line and fuel supply line from fittings at tank and frame rail.
2. Remove fuel tank and all supports and brackets.
3. Remove and discard fuel supply and vapor lines.
4. Remove inner frame support at right side of tank.

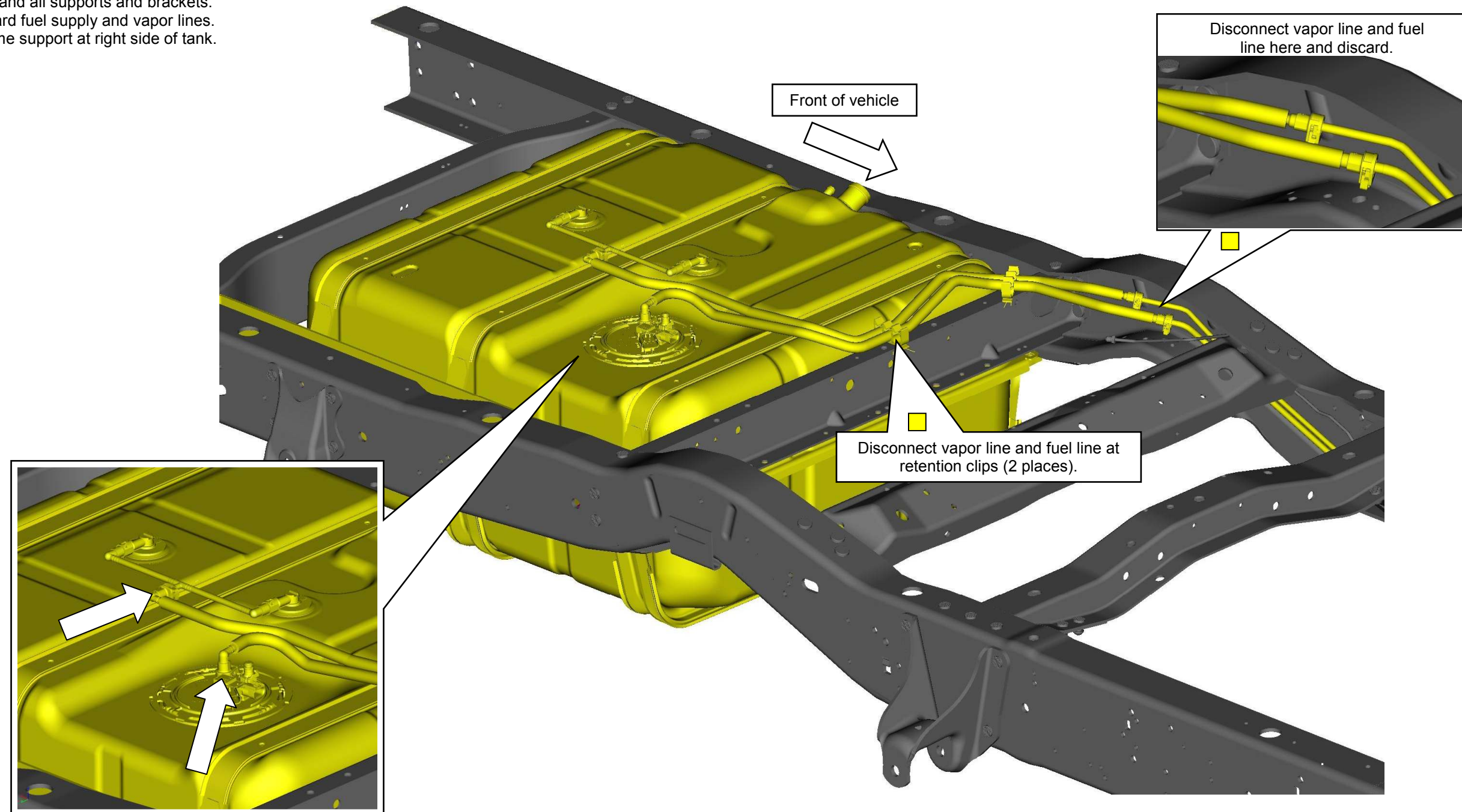

REMOVING ORIGINAL REAR FUEL AND VAPOR LINES

1. Remove vapor line from retaining clips on frame rail, disconnect from evaporative canister and discard.
2. Remove evaporative canister and fresh air hose following procedure in *Ford Workshop Manual, Section 303-13, Evaporative Emissions*. Disengage the bracket from the frame rail and crossmember. Leave the canister attached to the bracket.
3. Remove gasoline rear fuel supply line from retaining clips. Leave clips in place for new fuel lines.

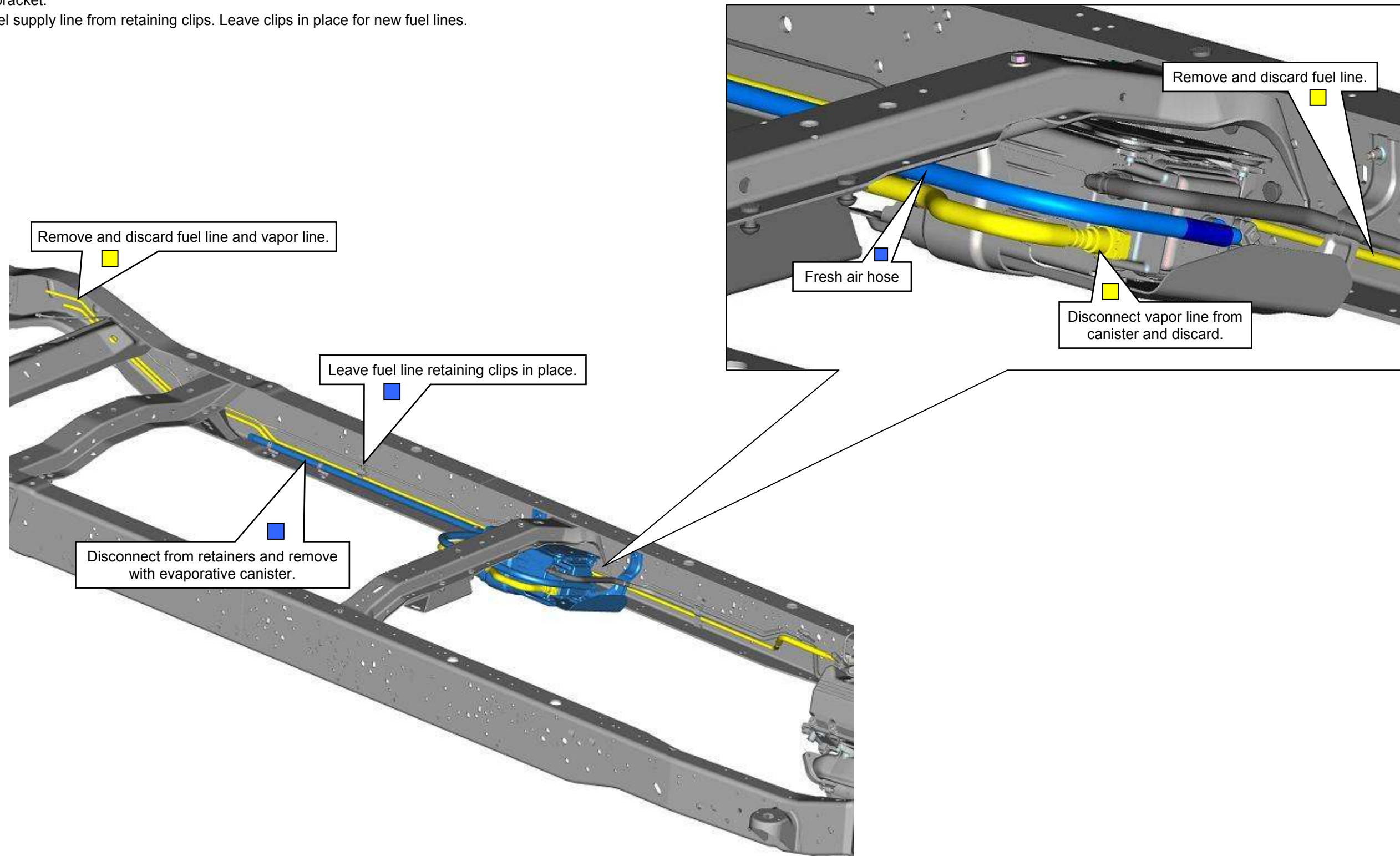

REMOVING ORIGINAL FORWARD FUEL SUPPLY LINE

Refer to the *Ford Workshop Manual, Section 310-01, Fuel Tank and Lines*, for complete instructions for removing the original forward fuel supply line and setting aside the evaporative canister.

If installing this kit on an unfinished vehicle (no box or bed installed), the filler pipe, fuel supply and vapor lines (at tank) can be removed along with the fuel tank.

1. Disengage the forward fuel supply line from retention clips, disconnect from fuel rail and discard line.
2. Disconnect the heated exhaust gas oxygen (HEGO) sensor harness and connector from the line bracket at transmission.

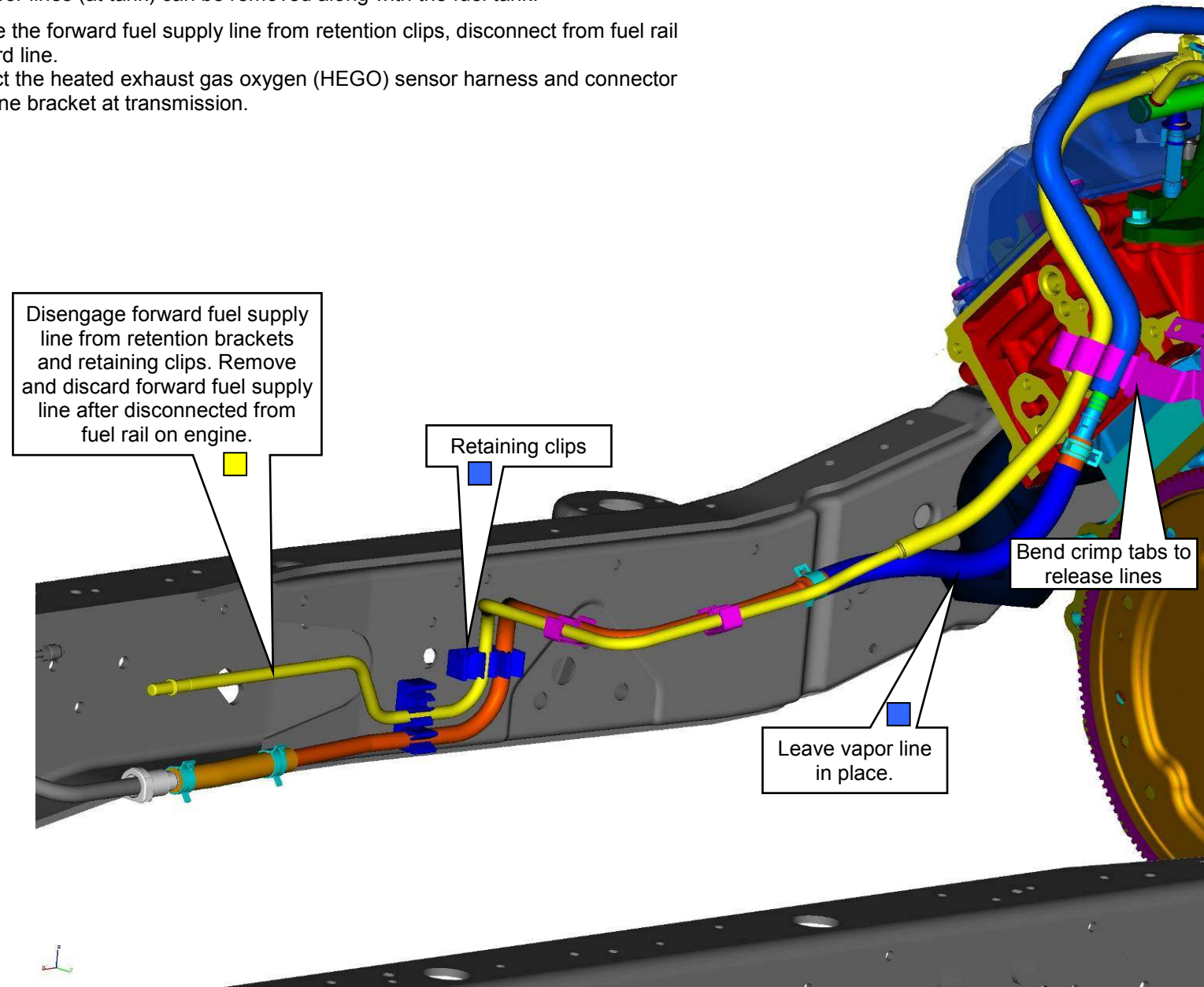

REMOVING ORIGINAL FILLER PIPE

Refer to the *Ford Workshop Manual, Section 310-01, Fuel Tank and Lines*, for complete instructions for removing the original filler pipe.

If installing this kit on an unfinished vehicle (no box or bed installed), the filler pipe, fuel supply and vapor lines (at tank) can be removed along with the fuel tank.

- If equipped, remove the gasoline cap, bracket and filler pipe assembly from the vehicle. Remove all associated hardware.

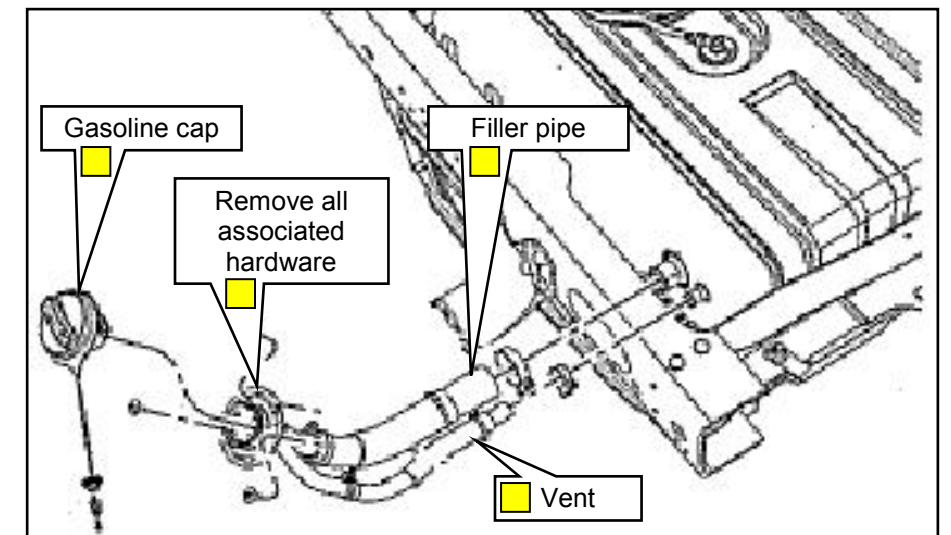

INSTALLING NEW FORWARD FUEL LINES

After removing original gasoline fuel line and removing filler pipe, temporarily position ROUSH CleanTech forward fuel supply and return lines from under vehicle so lines extend into engine compartment near intake manifold. Final installation is after installation of fuel rail pressure control module (FRPCM).

1. Remove left exhaust heat shield as needed. Be careful of sharp edges.
2. Install forward fuel supply line and forward fuel return line from underneath vehicle. Follow 5/8" vapor management valve (VMV) line and route both lines above LH exhaust heat shield (remove if necessary) through transmission bellhousing bracket and up into engine compartment. Do not close retention bracket at bellhousing or snap lines into retainer until FRPCM is installed. Also, detach HEGO sensor connector from bracket and zip tie connector securely to fuel supply line.
3. Install 1/4 to 3/8" ethylene propylene diene monomer (EPDM) sleeves on 1/4" diameter fuel line at retention clips on frame rail.
4. The rearmost retaining clip for new forward fuel lines might be mislocated. Move clip forward to next frame hole location, approximately 25-3/4 inches forward of parking brake equalizer.

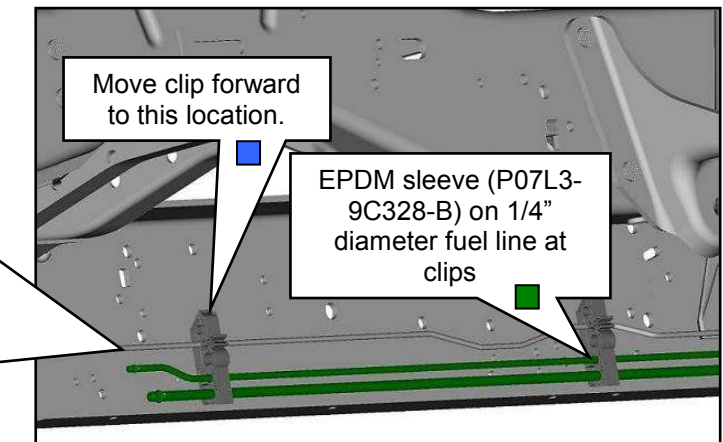
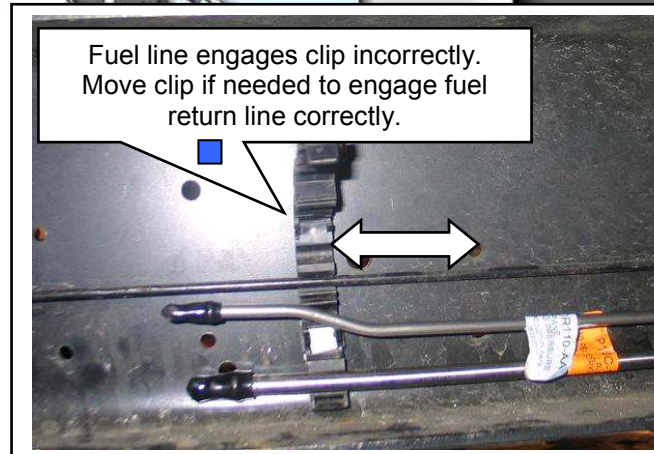
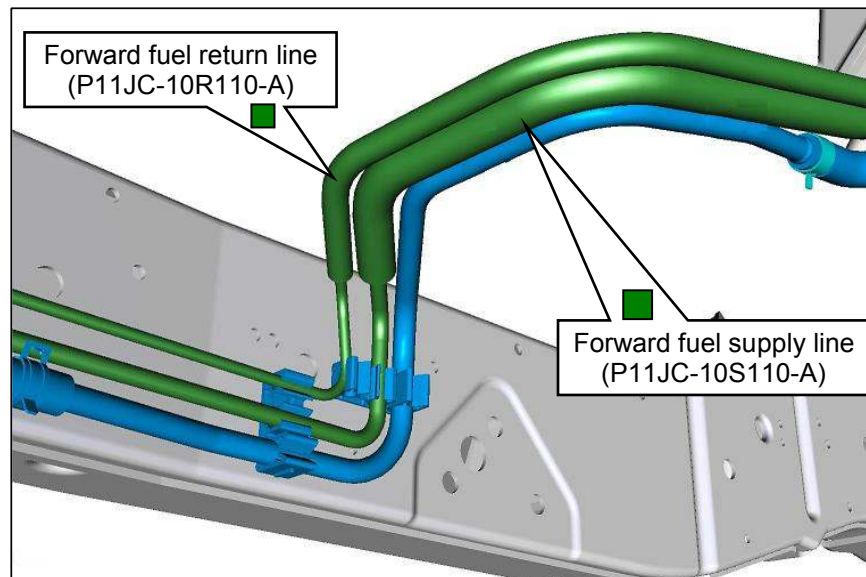
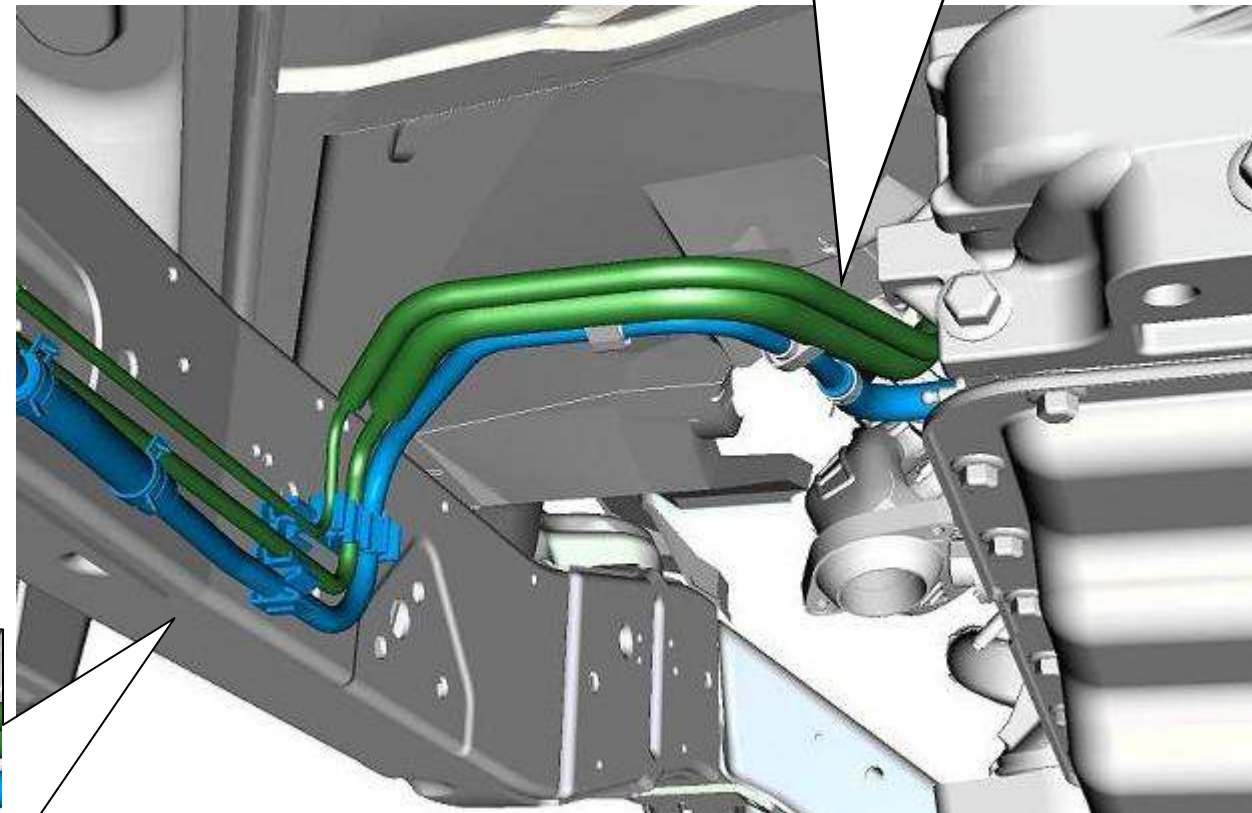
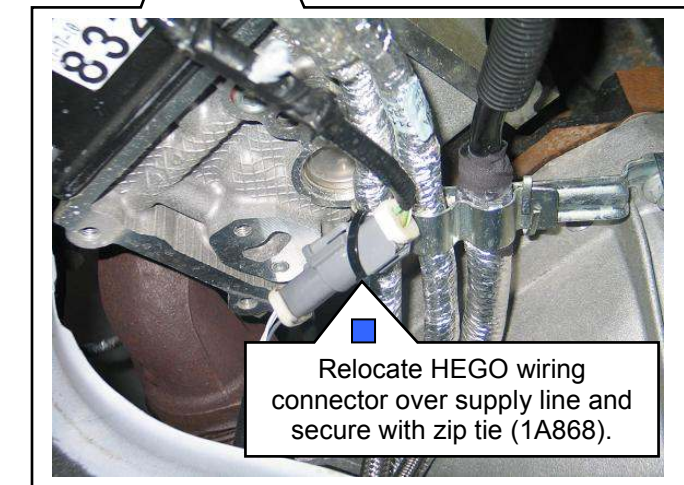
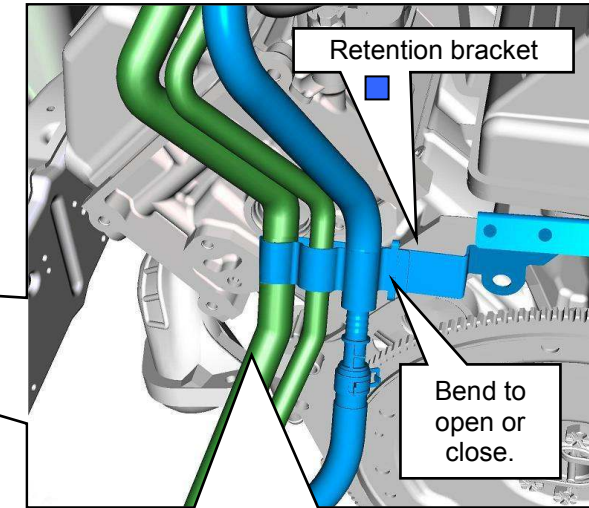
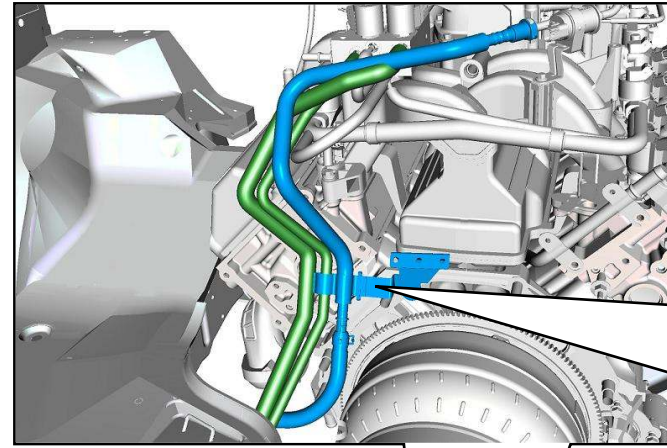

PREPARING THE FRAME

1. Remove gasoline tank mounting hardware, bolts, nuts and brackets.
2. Prepare the frame rails by drilling holes where indicated.
3. After frame rail preparation, install frame mounting brackets and M12 x 1.75 x 35 bolts. Tighten bolts to 100–110 Nm.
4. Install frame rail washers, two locations on right, rear location on left.
5. Insert M12 x 1.75 x 55 bolts, two on right, rear on left, through frame washers and frame rail.

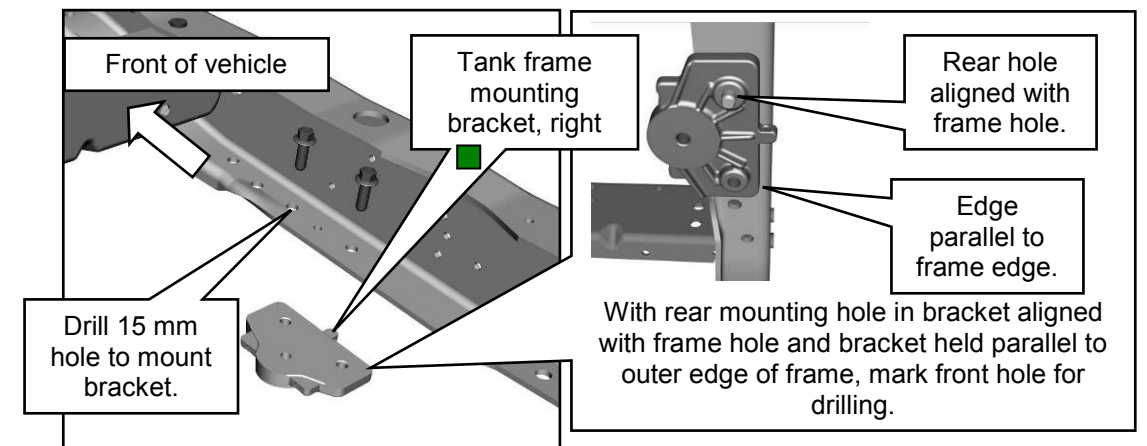
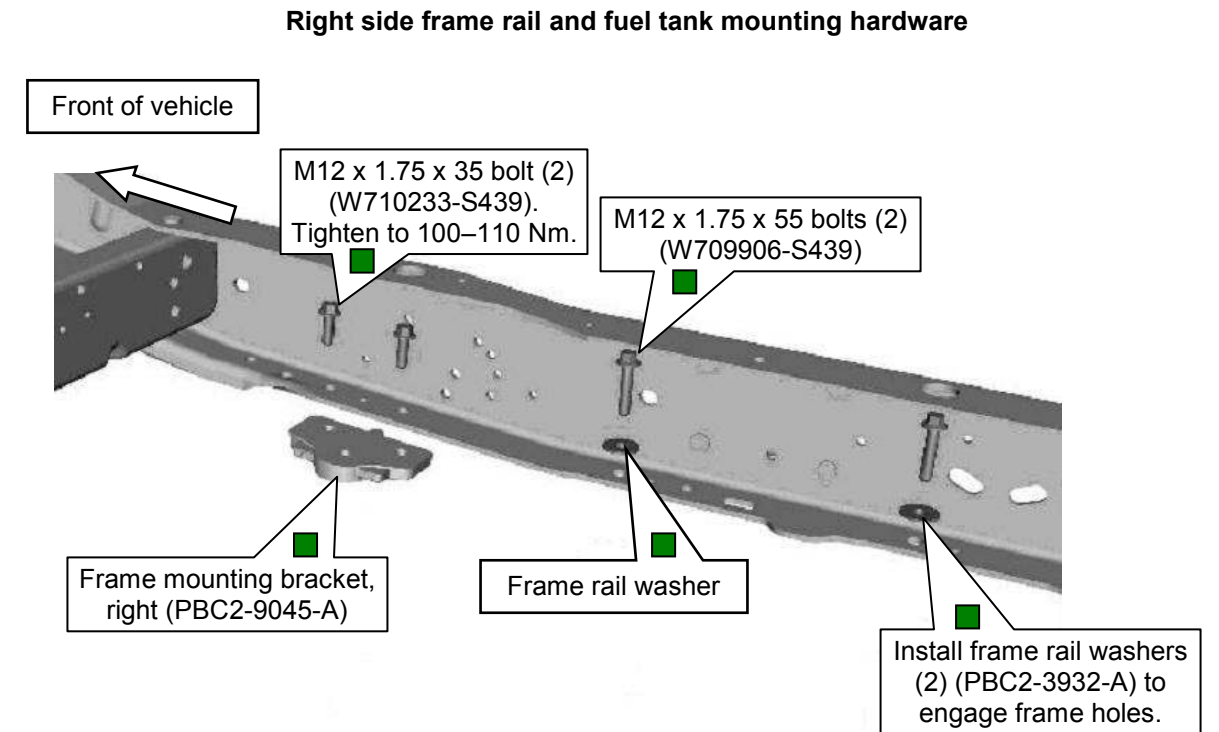
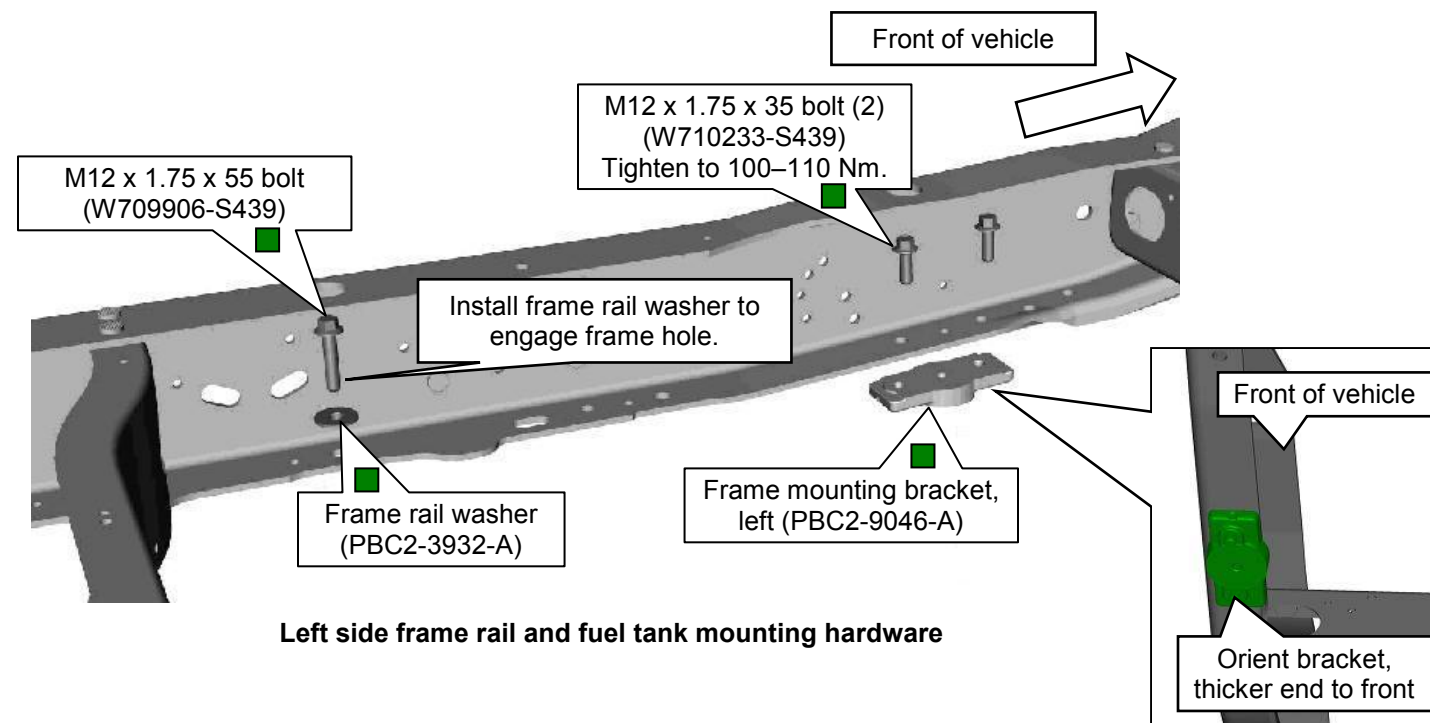
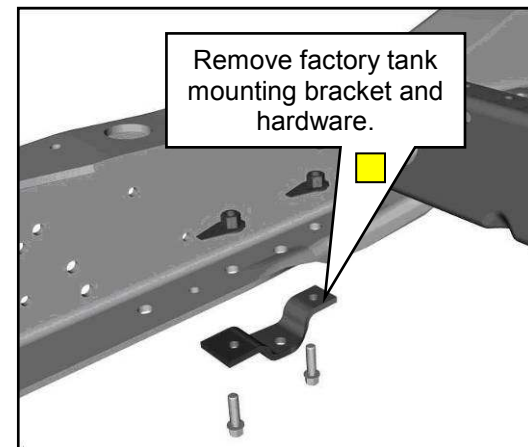
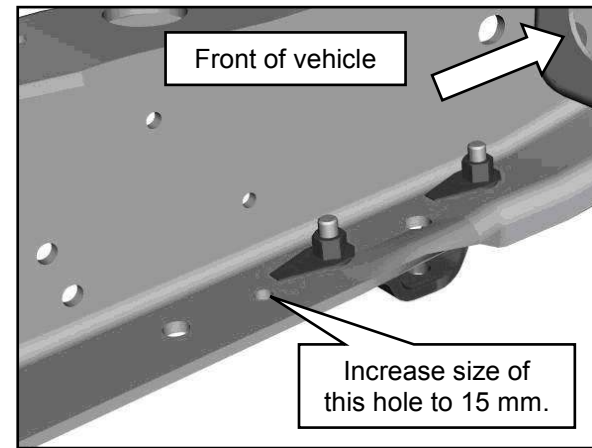

INSTALLING NEW REAR FUEL LINES AND FLEX COUPLINGS

1. Route new rear fuel supply line and rear fuel return line along frame rail from rear to front. Position lines behind and through crossmembers, align and connect lines into fuel return line (flex line quick-coupling) and fuel supply line (flex line quick-coupling).
2. Attach lines into retaining clips along frame rail and snap in place.
3. Attach double snail retainer clip into rear fuel line support bracket.
4. Snap retainer clip and bracket assembly onto rear fuel lines just forward of flex portions of rear lines.
5. Position bracket against frame rail so that the fuel lines are centered in crossmember hole and the bottom of the bracket edge is flat on rail flange and align with hole in frame rail (158" WB). For 176" WB vehicles, center the bracket weld nut between the left front tank bracket bolts.
6. Mark location of weld nut and drill a 1/4" hole in web of frame rail (176" WB only). Reposition bracket, install M6 x 16 bolt through outside of frame rail to engage bracket nut and tighten to 8–12 Nm.
7. Install EPDM sleeves over flex portion of fuel lines before tank installation. Secure with two zip ties. Face opening of EPDM sleeves away from the frame rail.
8. Wrap fuel lines with convolute and two zip ties to secure convolute forward and rearward of hole in crossmember. Make sure convolute spans across crossmember through hole.

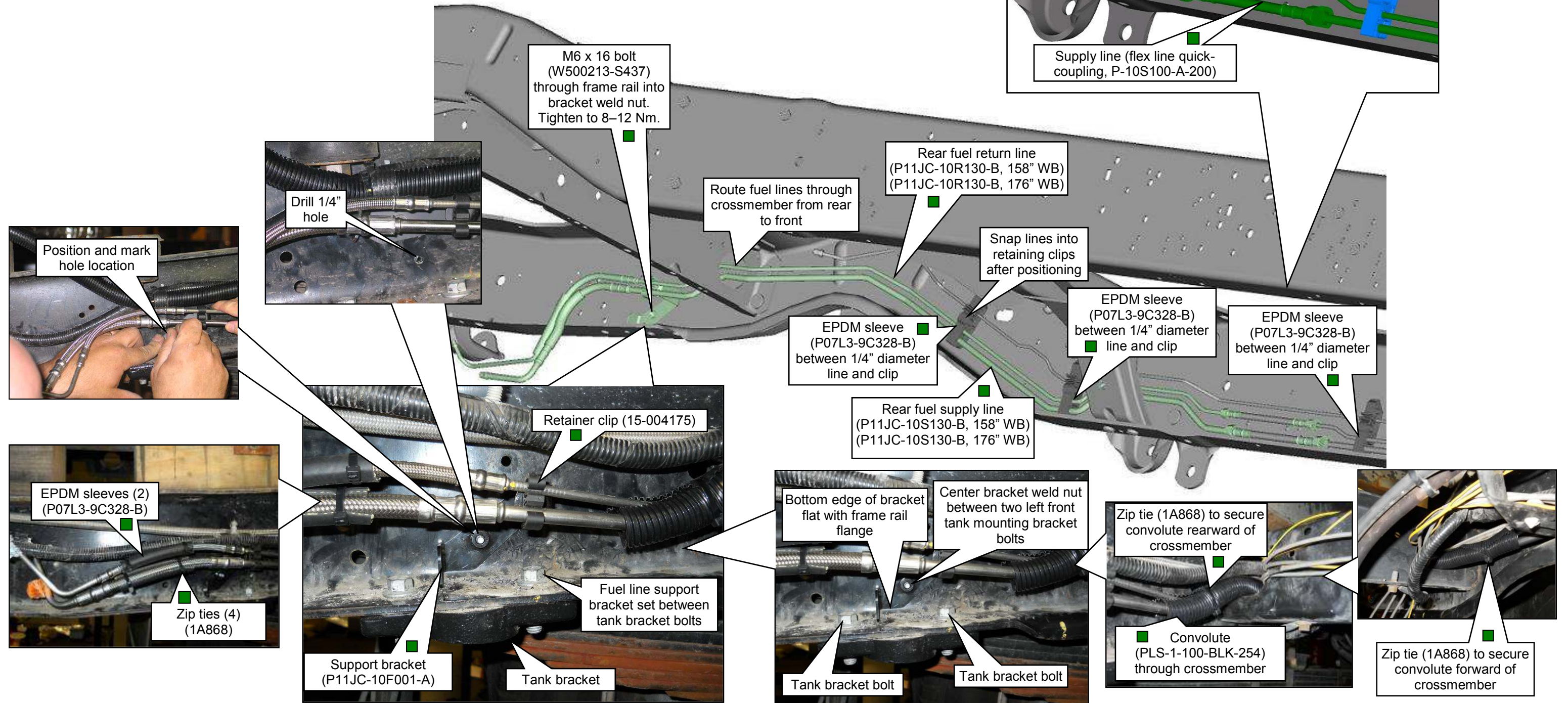
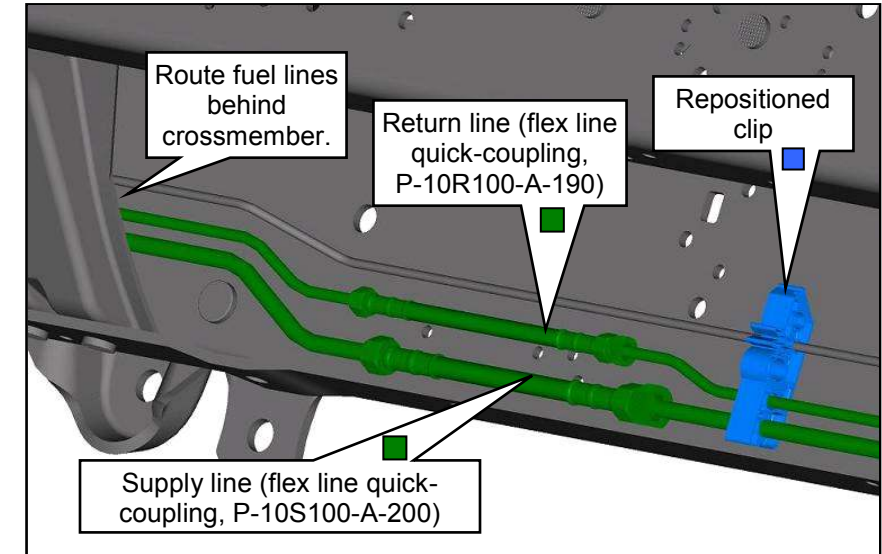

■ DISCARD
 ■ REUSE
 ■ NEW

INSTALLING NEW FUEL FILL SYSTEM AND FUEL FILTER

1. Remove nut and washer from fuel fill valve and assemble valve to fuel fill bracket. Support fill valve and bracket assembly and tighten nut securely. These parts are in hardware kit P11GD-FILLKIT-A.
2. If applicable, install fuel fill valve and fuel fill bracket behind factory fill area using three M5 x 16 mm bolts and washers. These parts are found in hardware kit P11GD-FILLKIT-A. Tighten the bolts to 5–7 Nm.
3. Install fuel fill line, nozzle-to-filter to fuel fill valve. Tighten to 41–49 Nm.
4. Install 62" of convolute over fuel fill line, nozzle to filter, making sure to cover the entire braided portion of the line. Secure with a zip tie at each end.
5. Route fuel fill line over left frame rail and back toward rear crossmember.
6. Secure fuel fill line as necessary using two cable tie edge clips to route fill hose over frame rail to mounting location between fill valve and filter. For vehicles without body, secure the fill line to the center of the fuel tank, after tank installation.
7. Position the standard template against the bottom of the crossmember. Mark (center punch) the location for drilling a new hole. Refer to the *Special Tools* section for the size and dimensions of the template. Drill 1/4" hole in lower flange of crossmember. **Note:** The filter, bracket and clamp can be installed in an alternate location based on vehicle body configuration. Install the parts at the top front of the crossmember, instead of the bottom rear. Use the alternate template as shown to determine the drilling location of the holes for the two bracket bolts. Place the template at the top rear of the crossmember, centerpunch and drill the holes.
8. Install filter bracket to crossmember. Tighten bolts to 8–12 Nm.
9. Install filter clamp to bracket so it can be easily tightened (or loosened).
10. Install the fuel filter through the clamp and correctly positioned in the bracket. **Note:** The arrows on the fuel filter must point in the direction of fuel flow into the fill system; in to the filter from the fill valve and out of the filter to the fuel tank.
11. Tighten the clamp to secure the filter.
12. Connect opposite end of fuel fill line (end with 45-degree fitting) to fuel filter inlet. Tighten fitting to 53–61 Nm. Make sure to securely hold the 45-degree line fitting while tightening the line nut to avoid interference of line with crossmember or frame rail.

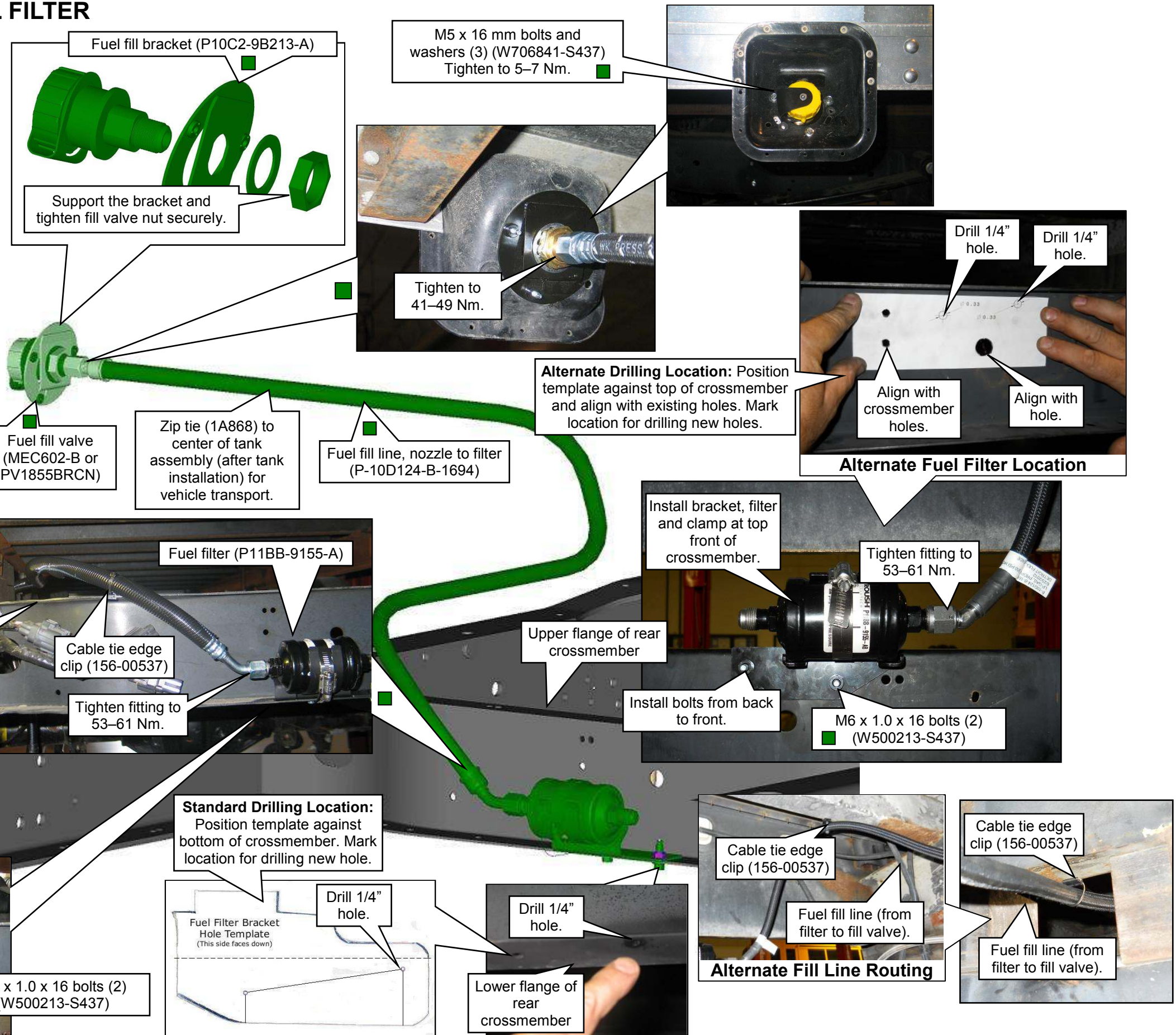

PREPARING ENGINE COMPARTMENT

Refer to the *Ford Workshop Manual, Section 303-04A, Fuel Charging and Controls, Removal and Installation*, for complete instructions on removing the fuel rails and injectors. Some original parts will be reused. The components in this section may be saved, discarded or new. Refer to color key.

1. Disconnect transmission dipstick tube/heater hose support bracket for clearance.
2. Disconnect and remove positive crankcase ventilation (PCV) hose.

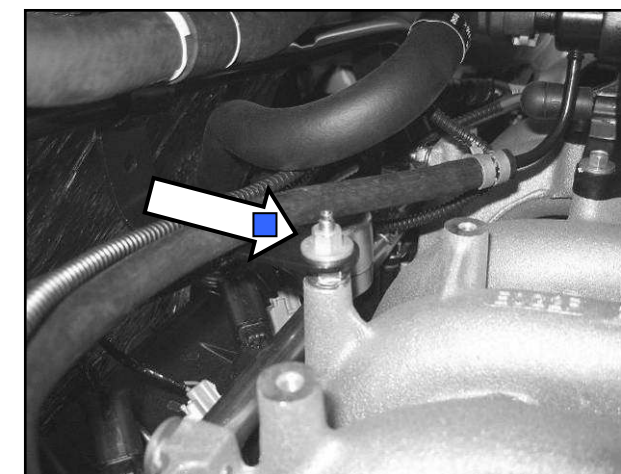
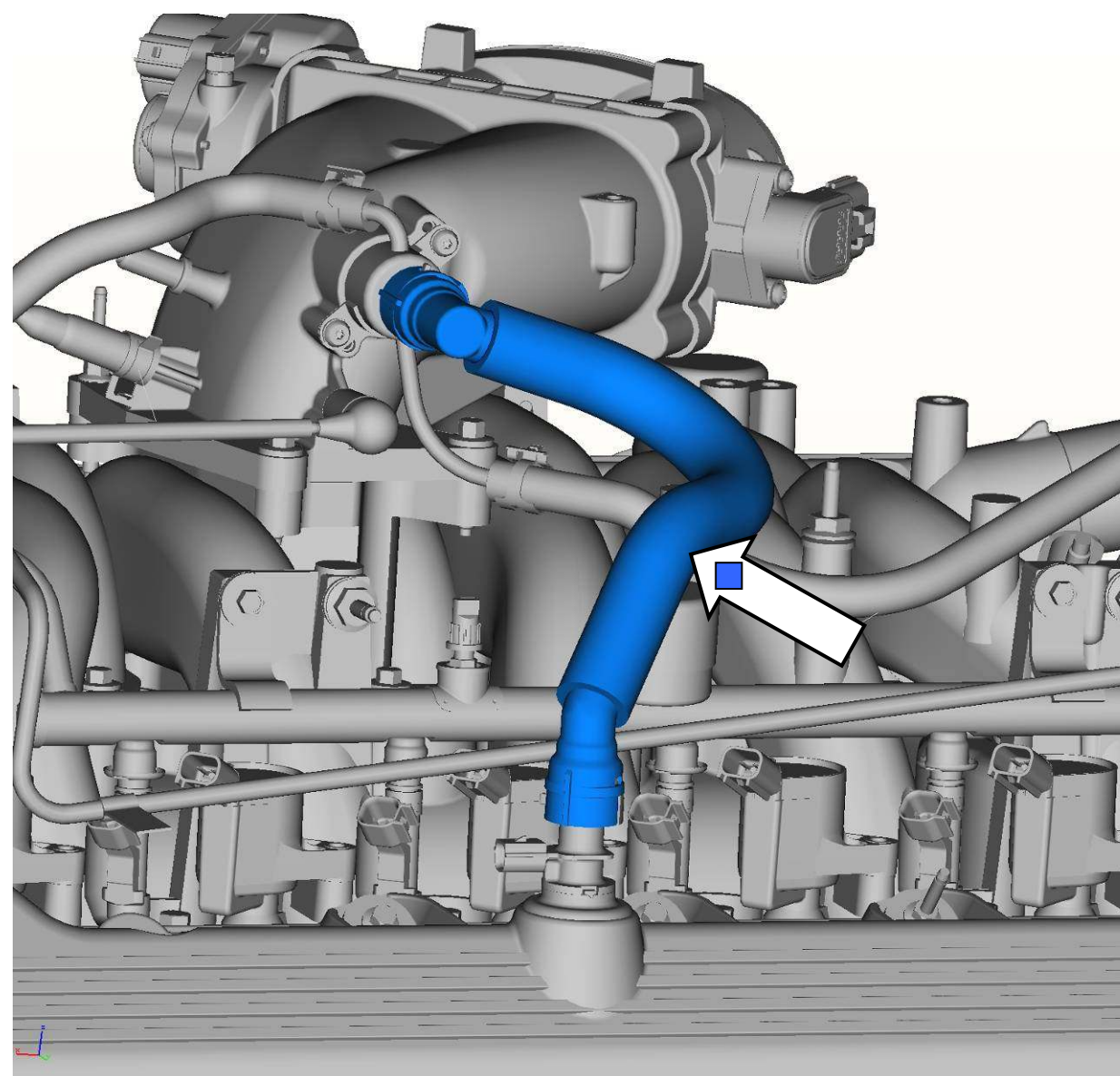

ROUSH CleanTech Liquid Propane Autogas Fuel System: Ford E-450 Dual Rear Wheel Cutaway

3. Unplug electrical harness connector (A) from VMV. Disconnect push-pin retainer (B) securing wiring harness to standoff bracket at rear of intake manifold. Remove bolt and harness standoff bracket (C) from engine. Save bolt for reuse and discard bracket.
4. Disconnect VMV tube quick-connect fitting (D) from VMV located at rear of engine. Disconnect quick-connect fitting (E) that connects VMV to rear of throttle body. Unbolt VMV bracket (F) from intake manifold, remove bracket from VMV and discard. Save bolt for reuse.
5. Install new VMV mounting bracket found in hardware kit P11JC-ENGKIT-A into rubber isolator of VMV, in same direction as removed. Rotate VMV hose 90 degrees to align with throttle body port.
6. Rotate quick-connect fitting on VMV tube 180 degrees.

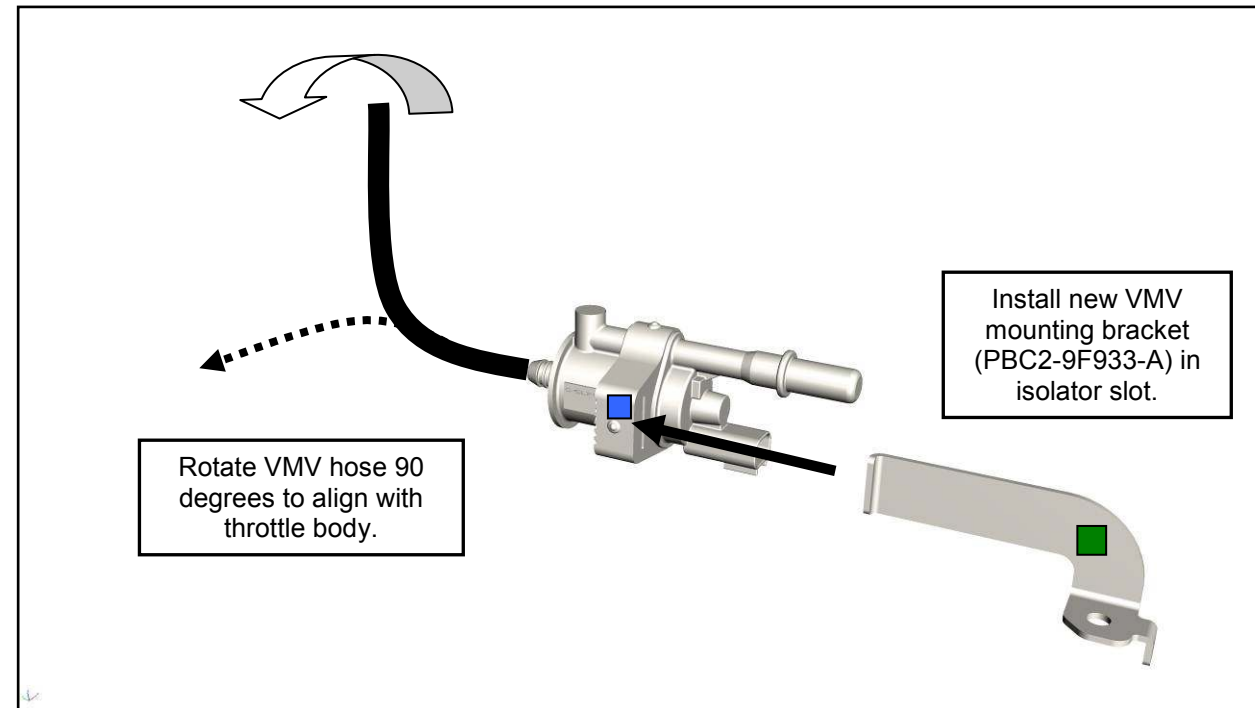
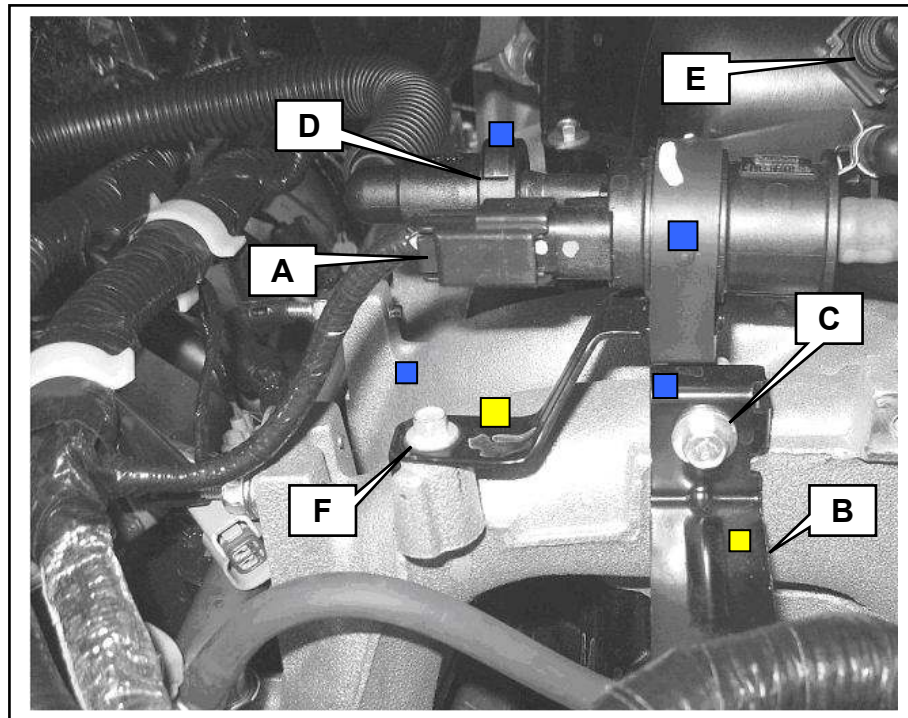
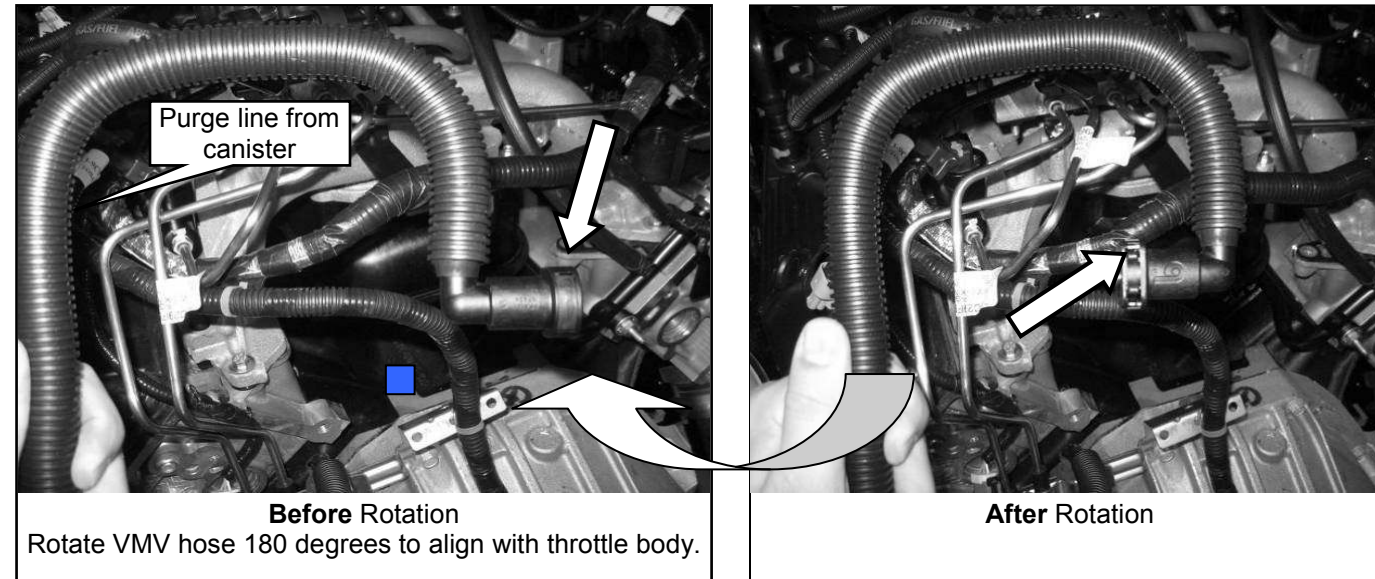

ROUSH CleanTech Liquid Propane Autogas Fuel System: Ford E-450 Dual Rear Wheel Cutaway

7. Remove engine wiring harness from mounting studs on intake manifold.
8. Disconnect electrical connector from each fuel injector.
9. Using a Ford-approved fuel line removal tool, disconnect fuel supply line from the fuel rail. Remove four fuel rail mounting bolts and fuel rail assembly. Discard fuel rail assembly and bolts.
10. Remove studs from intake manifold that were holding engine wiring harness. Discard studs.

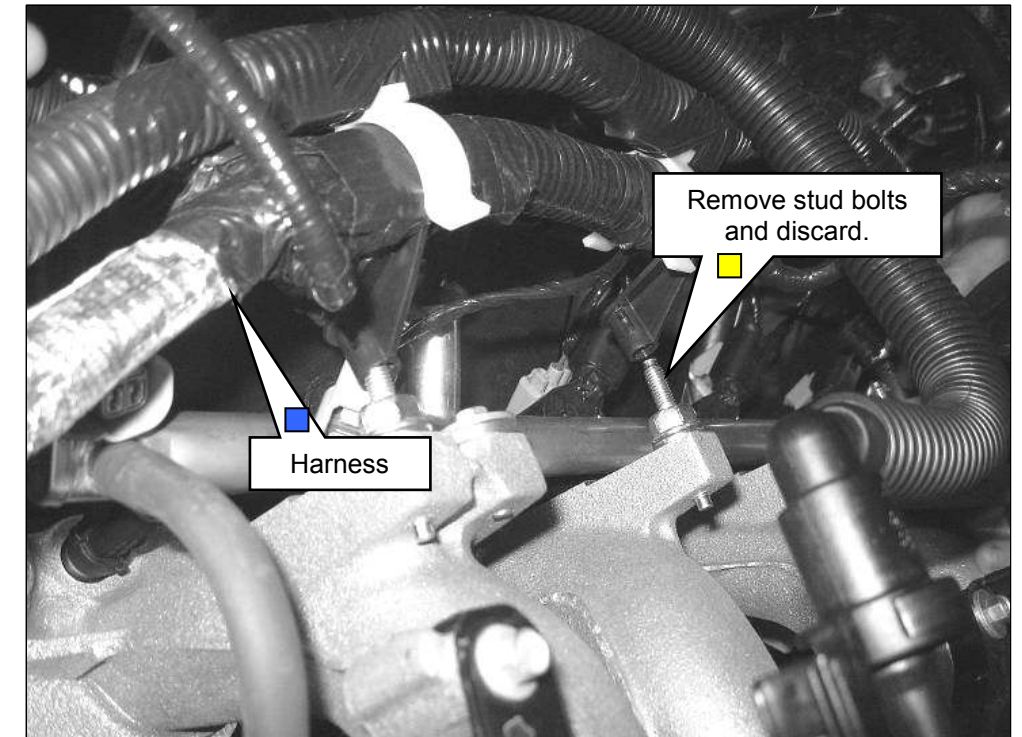
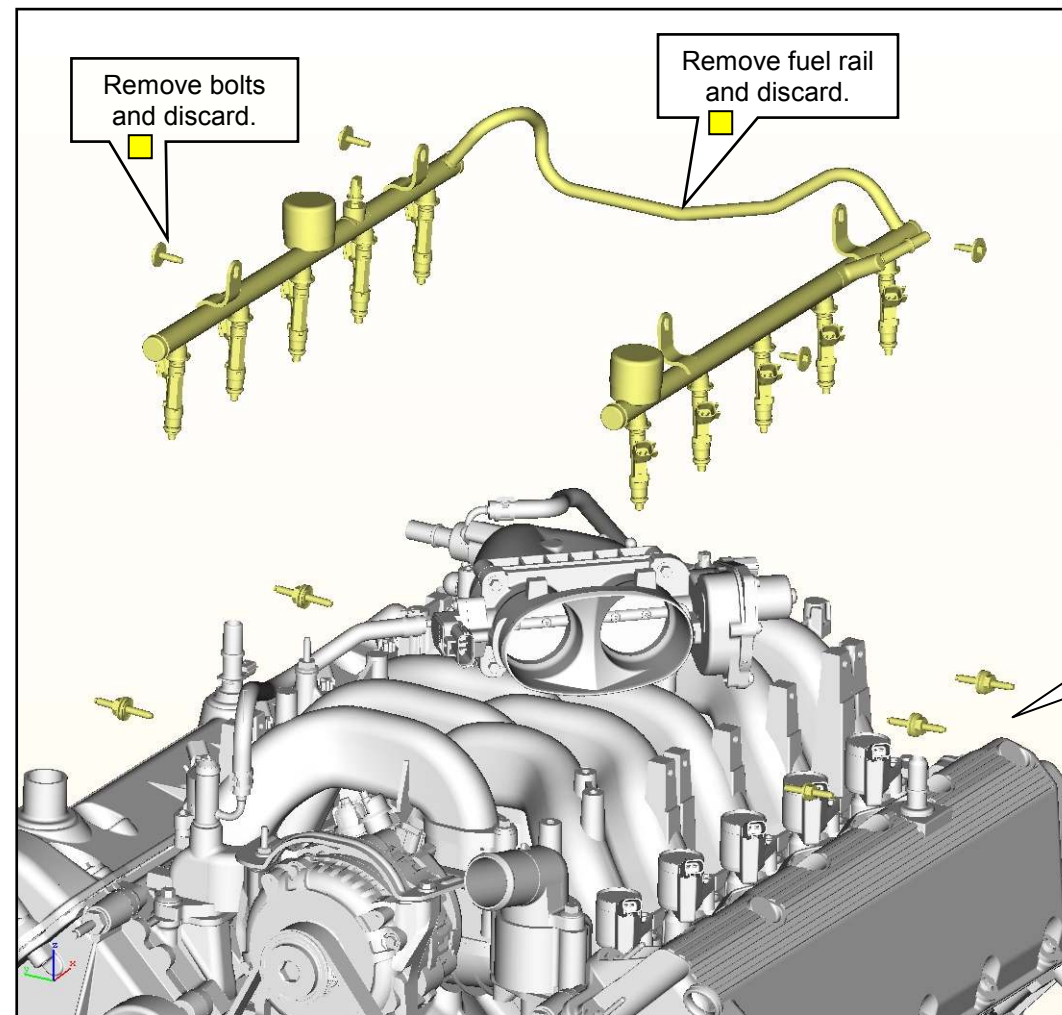
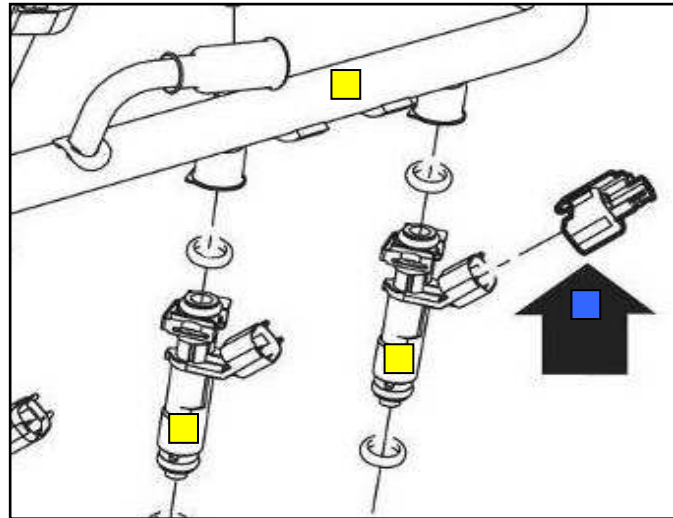

INSTALLING NEW FUEL RAILS

1. Disconnect coil wires for clearance.
2. Using engine oil (Motorcraft SAE 5W-20 or equivalent), lubricate lower O-rings on injector nozzles before seating rail assemblies.
3. Position left hand fuel rail assembly onto driver side of intake manifold and fully seat nozzles. Using two M6 x 40 bolts found in hardware kit P11JC-ENGKIT-A, secure fuel rail to intake manifold. Tighten bolts to 8–12 Nm.
4. Position right hand fuel rail assembly onto passenger side of intake manifold and fully seat nozzles. Using two M6 x 40 bolts found in hardware kit P11JC-ENGKIT-A, secure fuel rail to intake manifold. Tighten bolts to 8–12 Nm.
5. Orient and install fuel rail return line onto forward ends of fuel rails. Push to connect fittings.

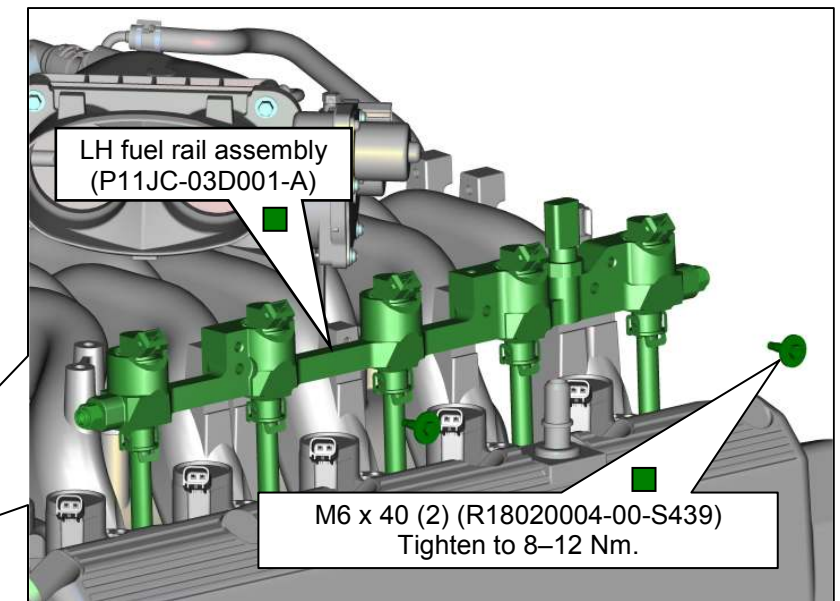
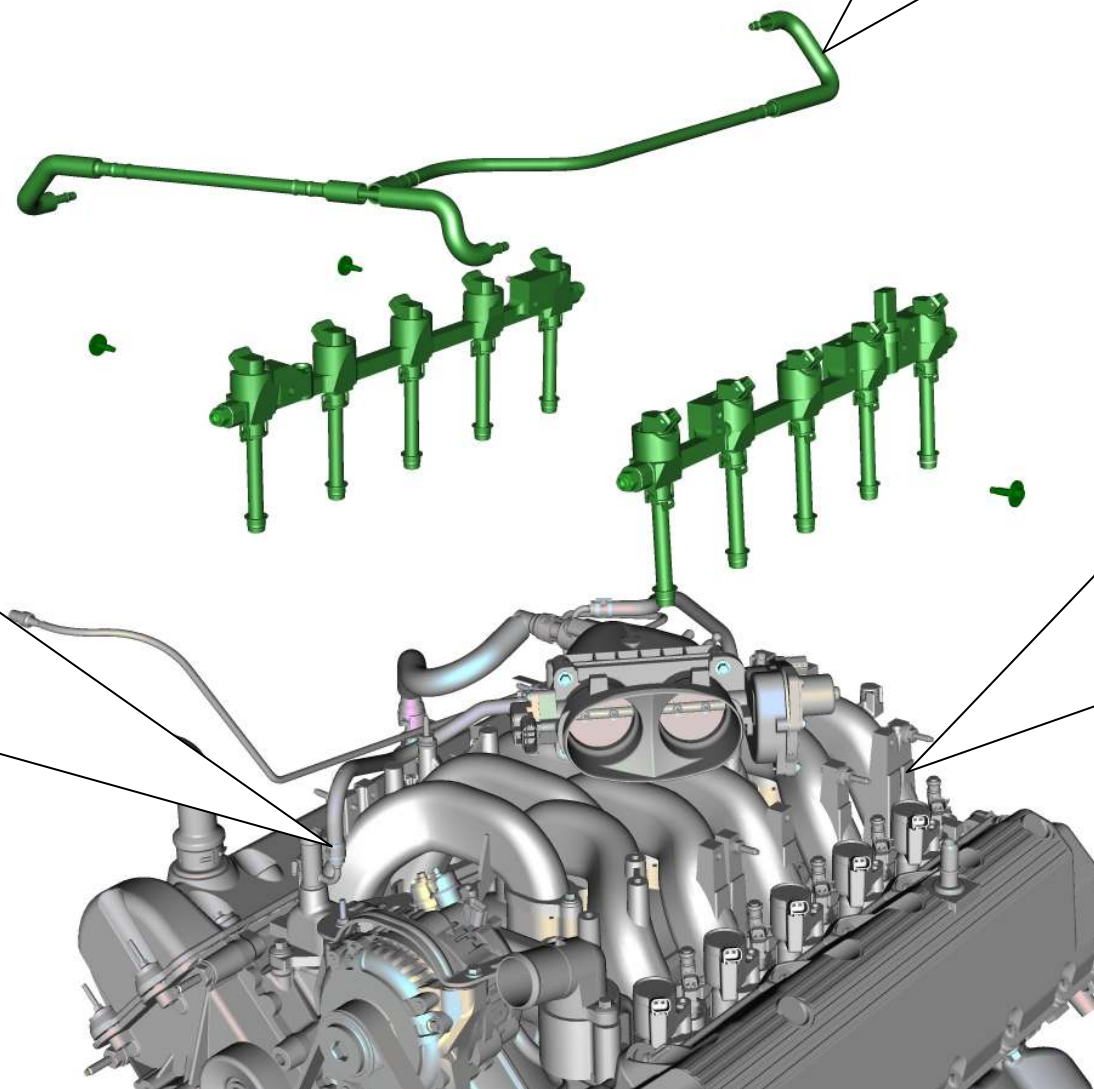
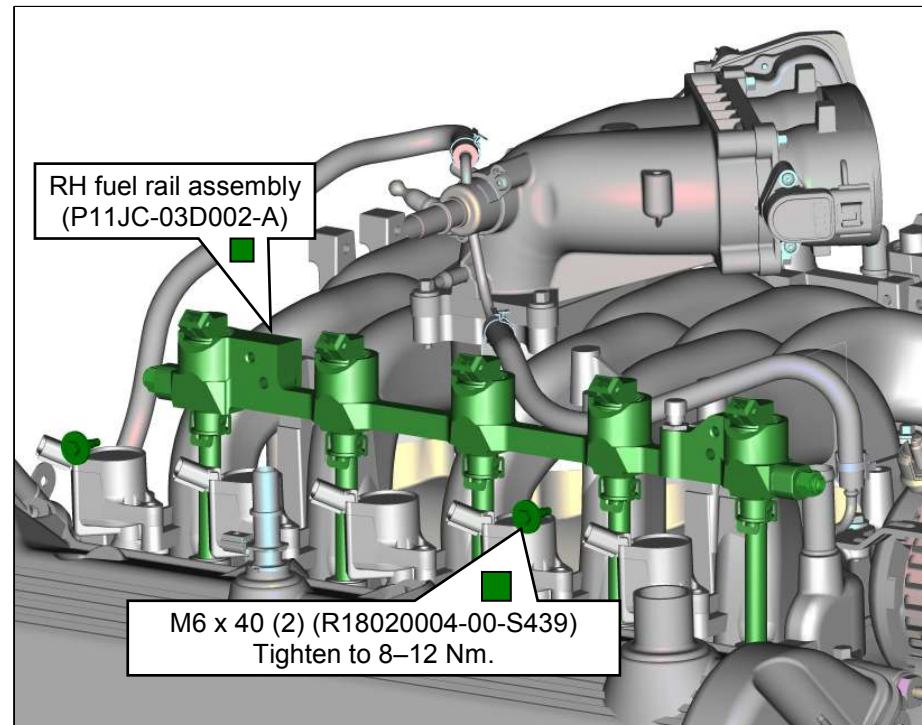
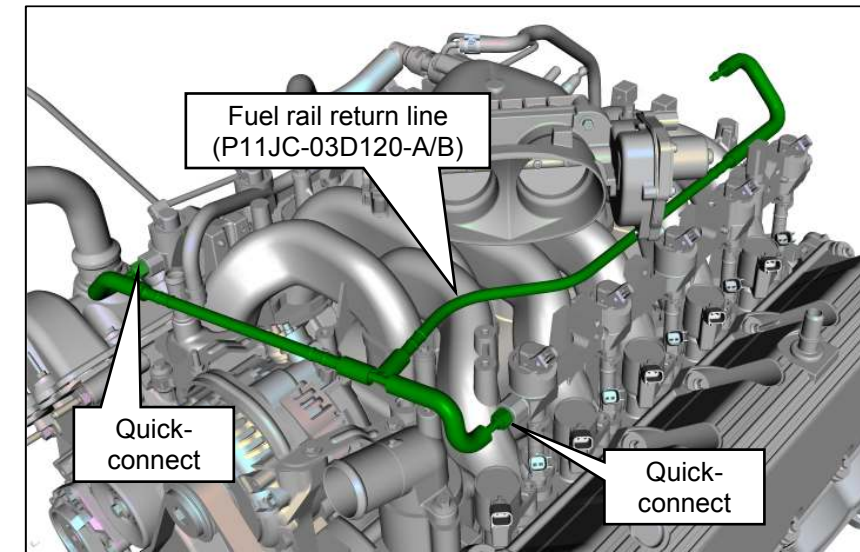

ROUSH CleanTech Liquid Propane Autogas Fuel System: Ford E-450 Dual Rear Wheel Cutaway

6. Reconnect coil wires.
7. Connect a fuel injector jumper to each original harness connector. The ten jumpers can be found in hardware kit P11JC-ENGKIT-A. Connect opposite end of each jumper to its respective fuel injector.
8. Install engine wiring harness to each fuel rail.
9. Install PCV hose. Flip PVC line 180 degrees so hose clears new fuel rail. Put 90-degree quick-connect fitting (A) onto valve cover port and 45-degree quick-connect fitting (B) on manifold port.
10. Install transmission dipstick tube/heater hose support bracket nut. Tighten nut to 8–12 Nm.

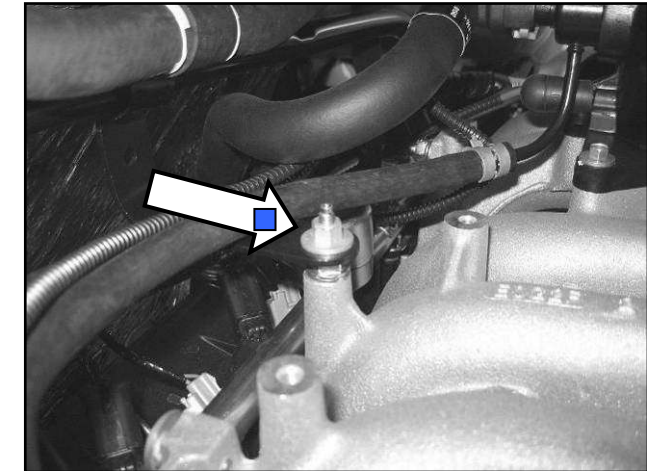
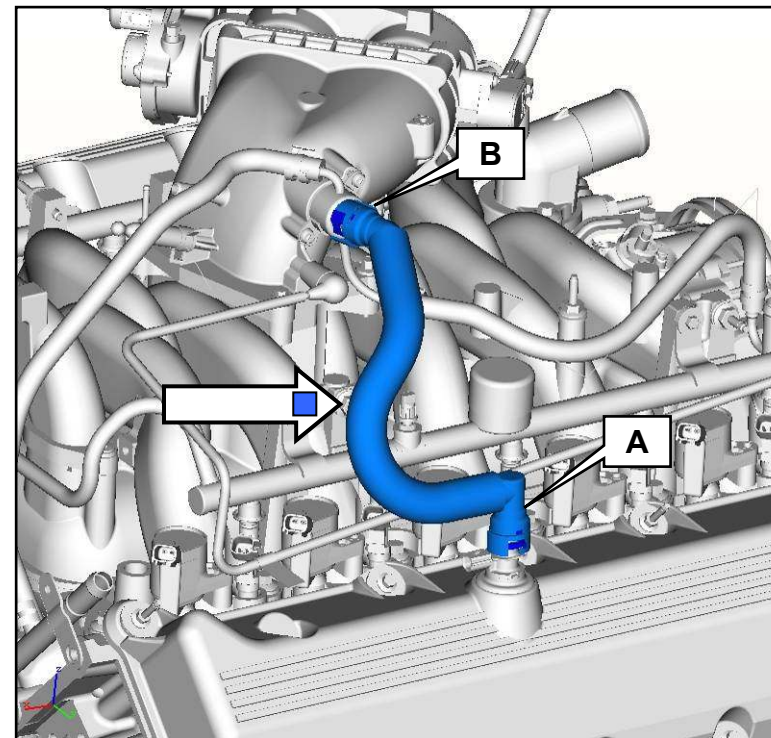
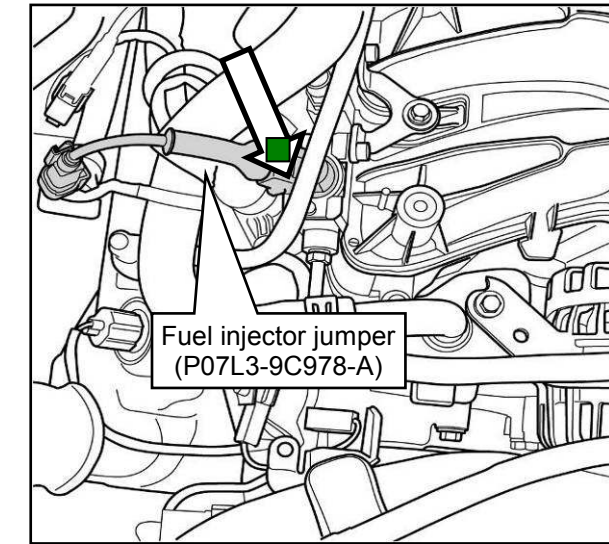
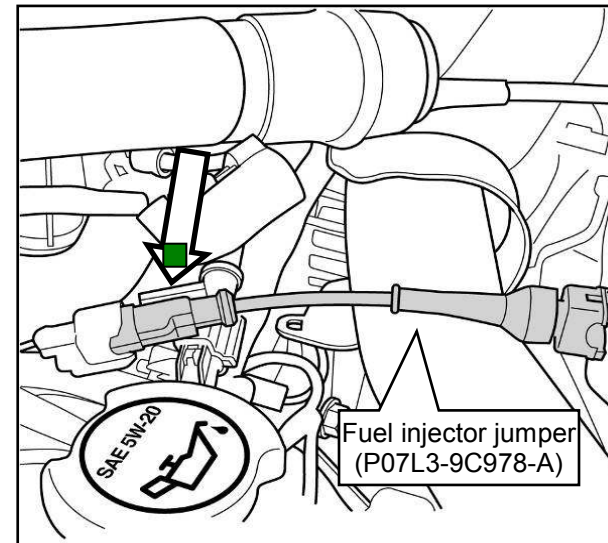
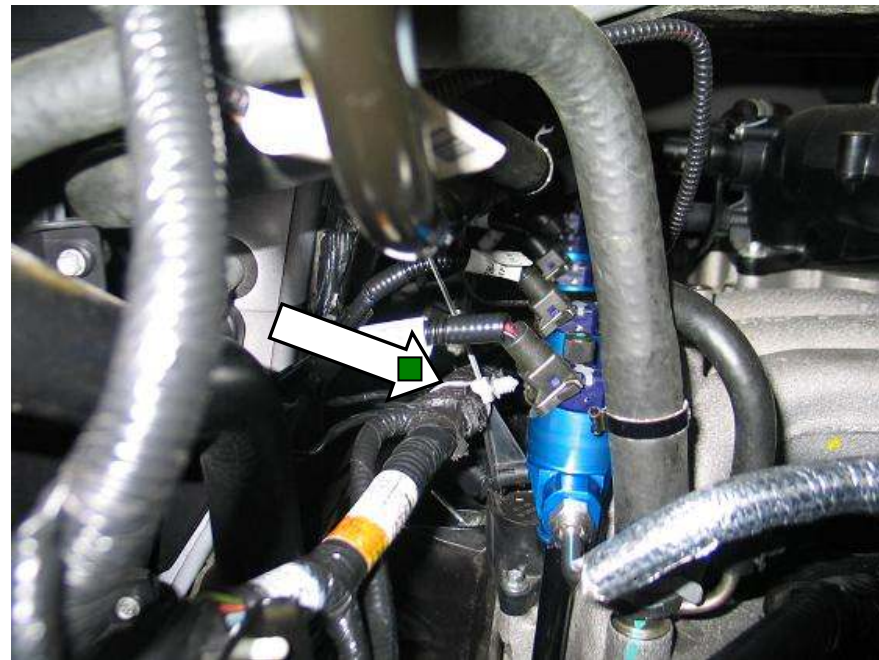

INSTALLING FUEL RAIL PRESSURE CONTROL MODULE

1. Remove and retain left-rear throttle body-to-intake manifold bolt. Save bolt for reuse.
2. Position FRPCM mounting bracket (PBC2-9E360-B) onto two bosses on intake manifold, on LH fuel rail and at left rear corner of throttle body. To secure the bracket, install two reused M6 (from original VMV and harness standoff brackets), one new M6 x 1.0 x 16 bolt and reused original throttle body bolt. Tighten bolts to 8–12 Nm. Parts are found in hardware kit P11JC-ENGKIT-A.
3. Install FRPCM to the mounting bracket using two M6 x 1.0 x 16 mm bolts and two M6 x 62 bolts. Tighten bolts to 8–12 Nm. Parts are found in hardware kit P11JC-ENGKIT-A.

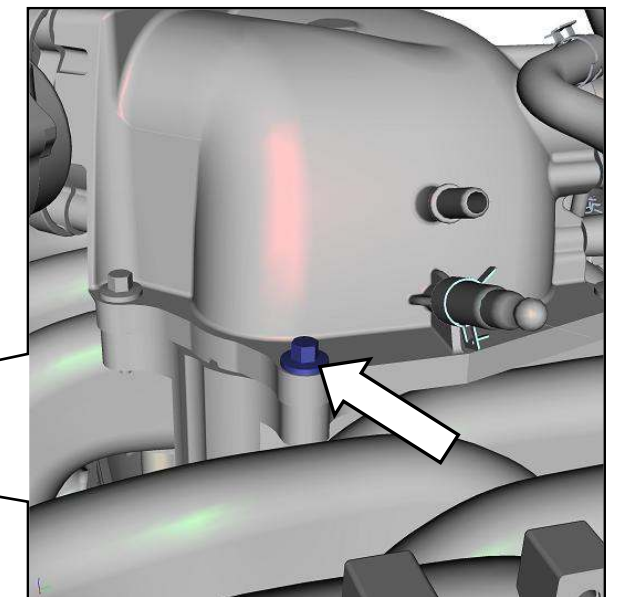
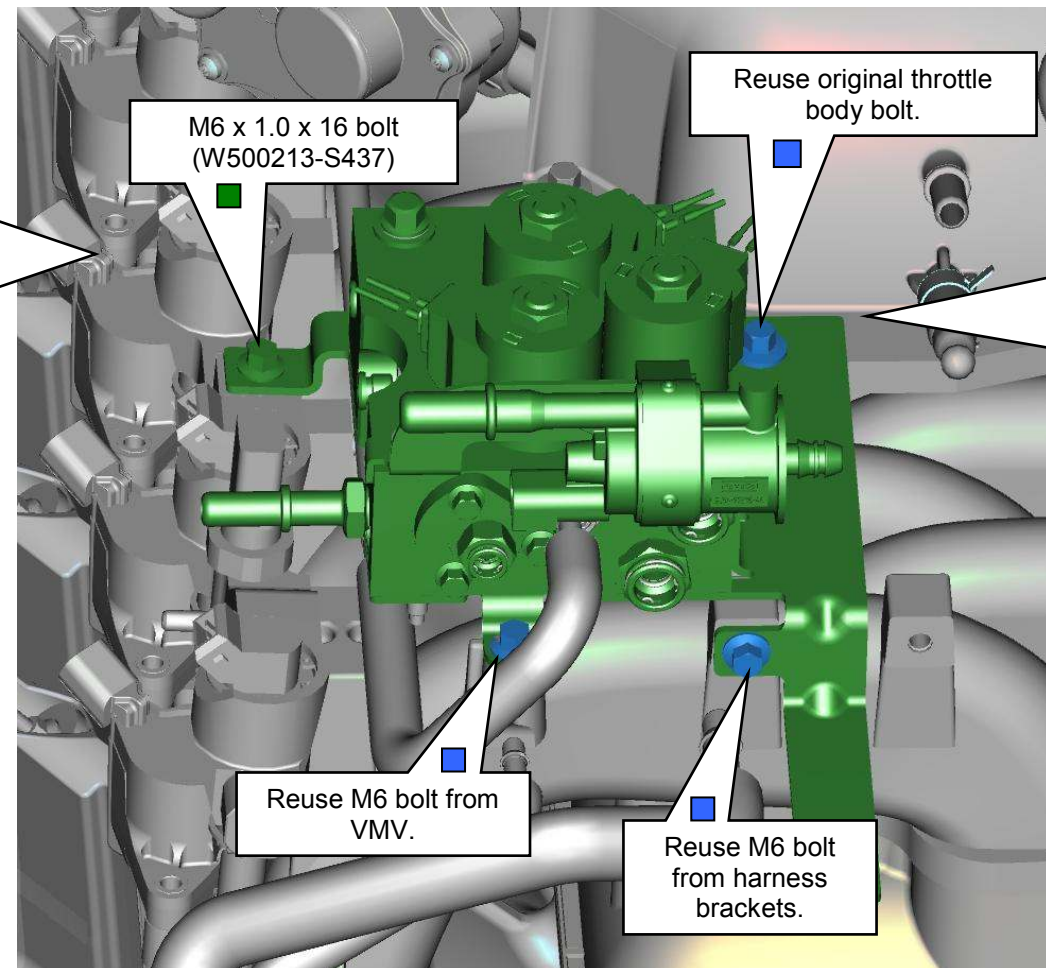
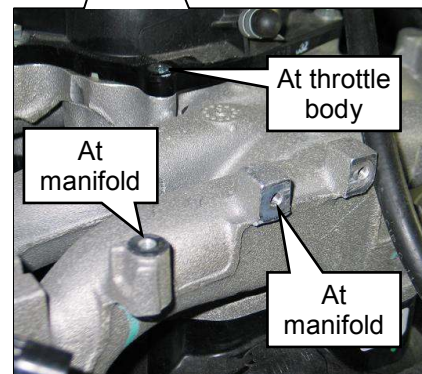
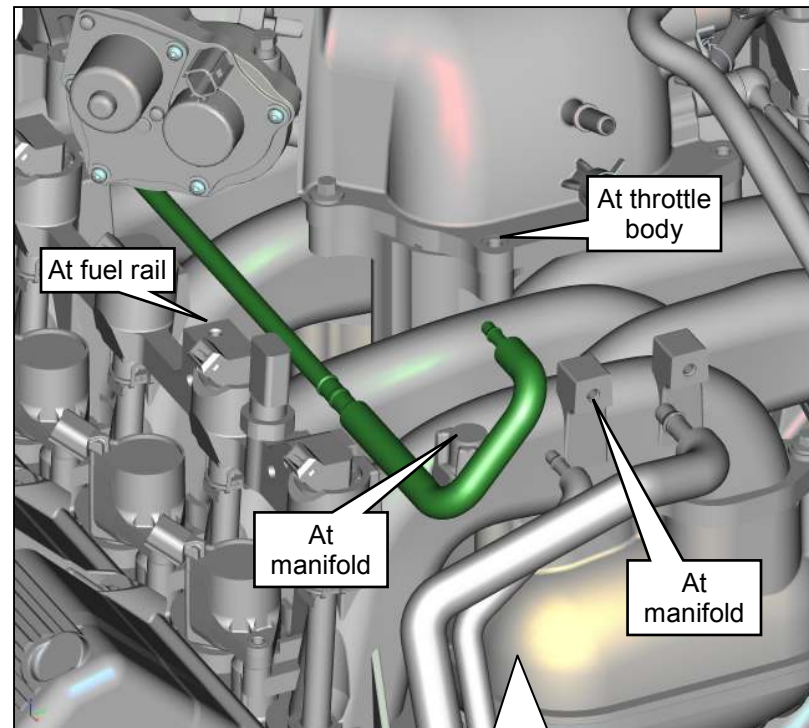
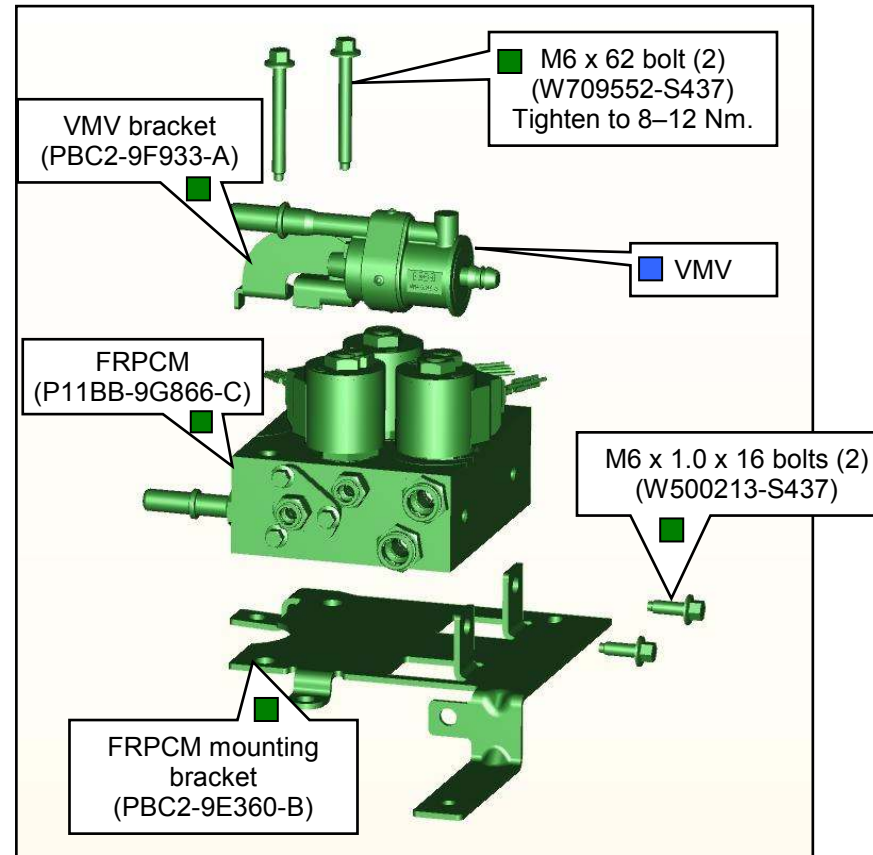

ROUSH CleanTech Liquid Propane Autogas Fuel System: Ford E-450 Dual Rear Wheel Cutaway

4. Connect fuel rail return assembly into top left port of FRPCM.
5. Install fuel rail supply assembly between left and right fuel rails and bottom right port on FRPCM. Plug quick-connect fittings into ports of FRPCM.
6. Connect the forward fuel supply and return lines into FRPCM. Plug quick-connect fittings into ports of FRPCM.
7. Connect vapor port on FRPCM to vapor management system using FRPCM purge hose assembly found in hardware kit P11JC-ENGKIT-A. The 90-degree fitting (A) connects to the FRPCM, the straight female fitting (B) connects to the VMV and the male fitting (C) connects to the factory VMV hose fitting.

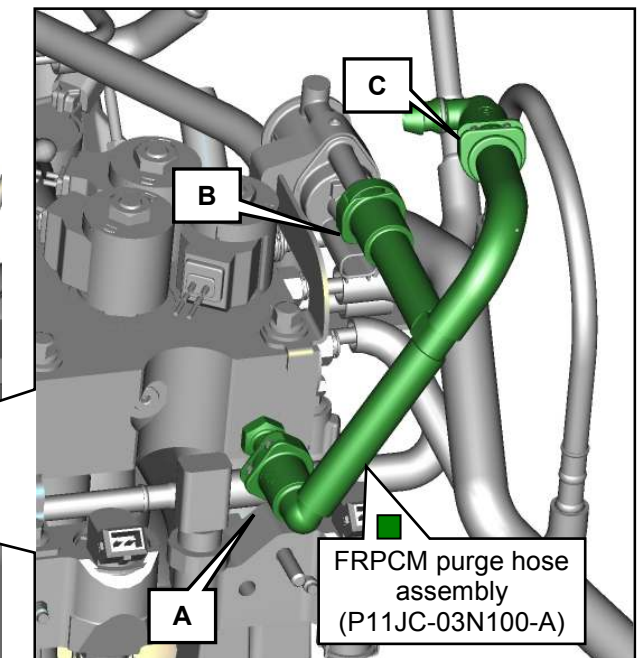
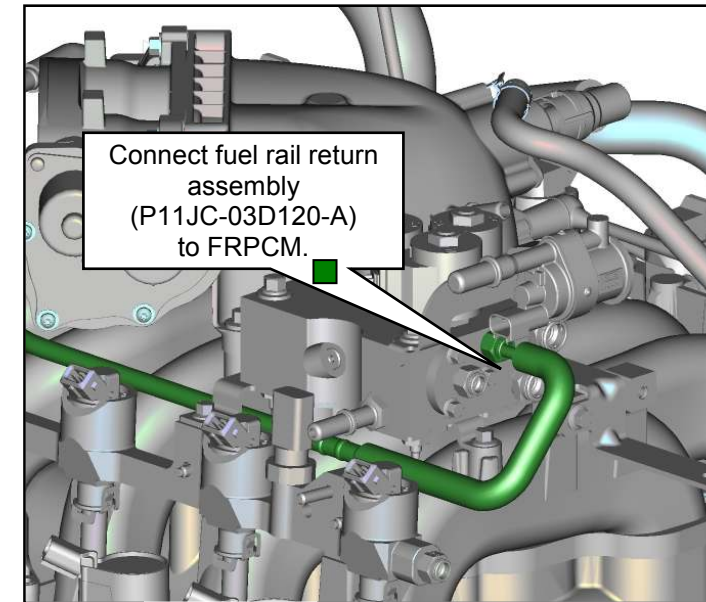
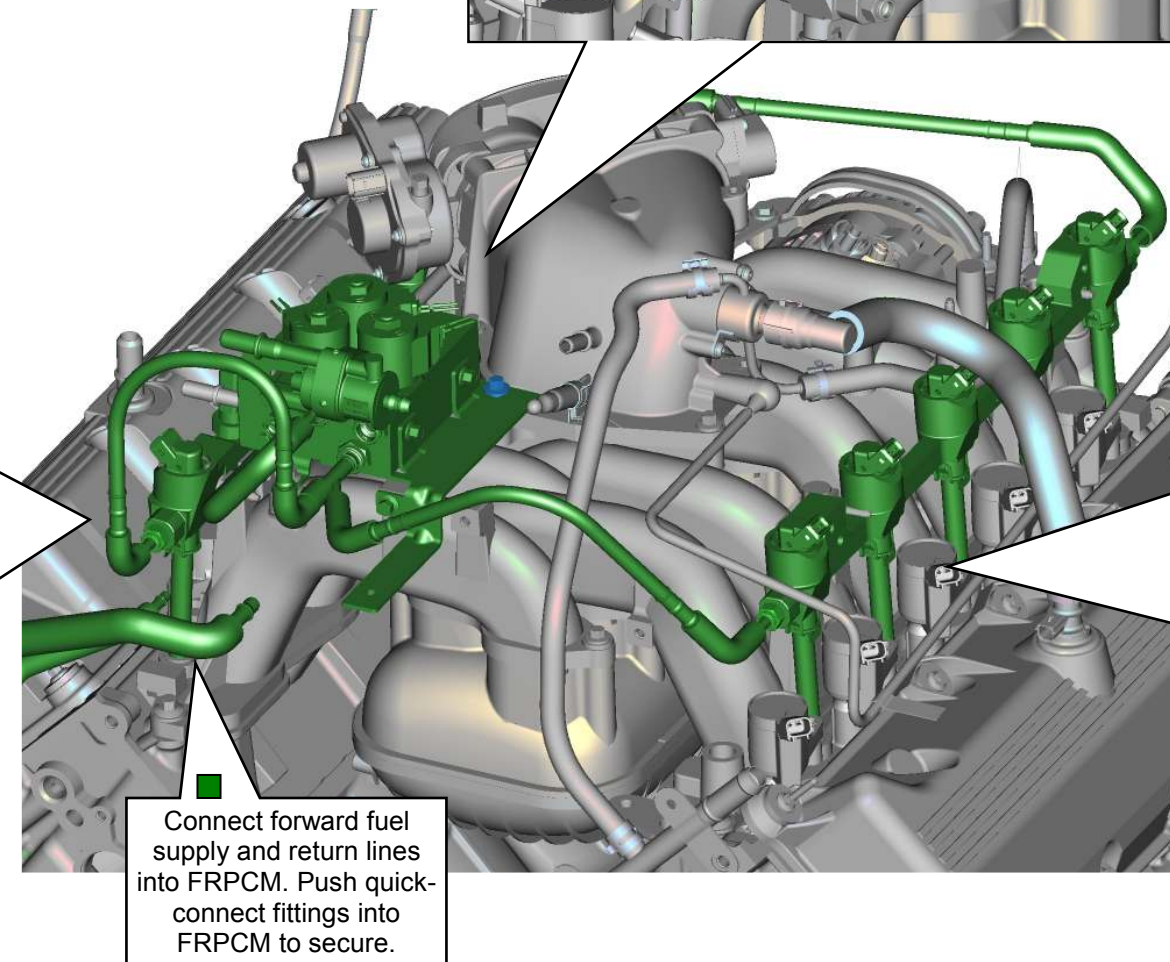
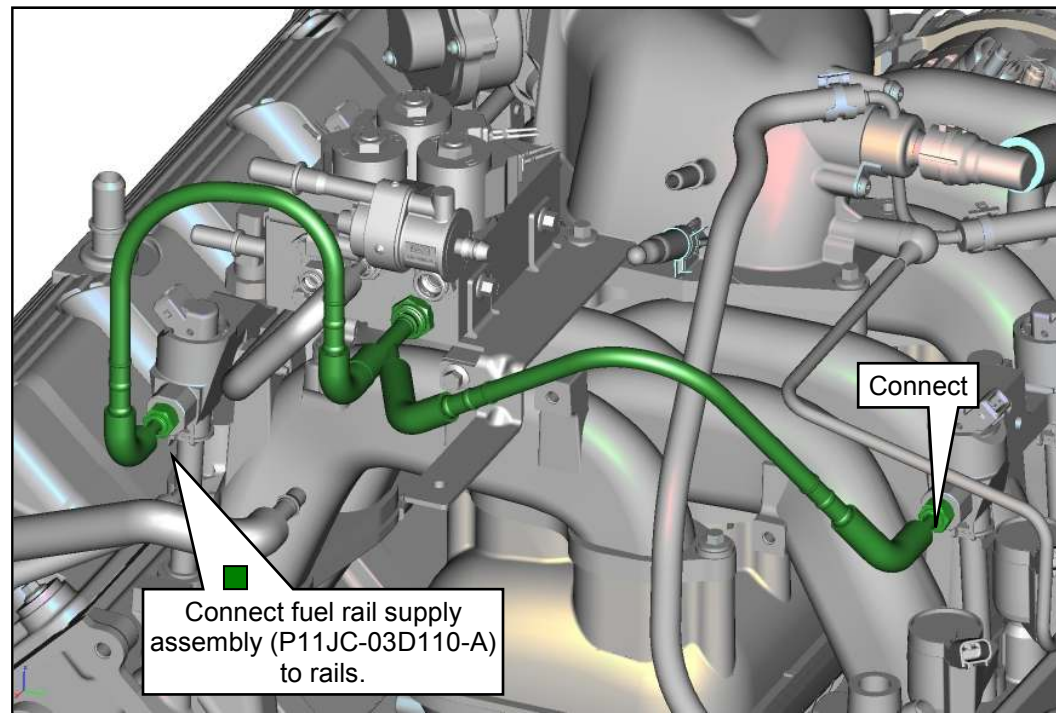

INSTALLING SMART RELAY MODULE AND AUXILIARY FUSE BOX BRACKET

Note: All parts for installing smart relay module (SRM) and auxiliary fuse box bracket are in hardware kit P11JC-ELECKIT-A.

1. Remove and retain three degas bottle mounting fasteners. Lay degas bottle on top of the brake master cylinder area.

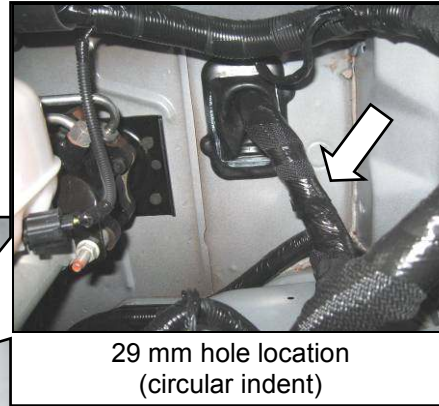
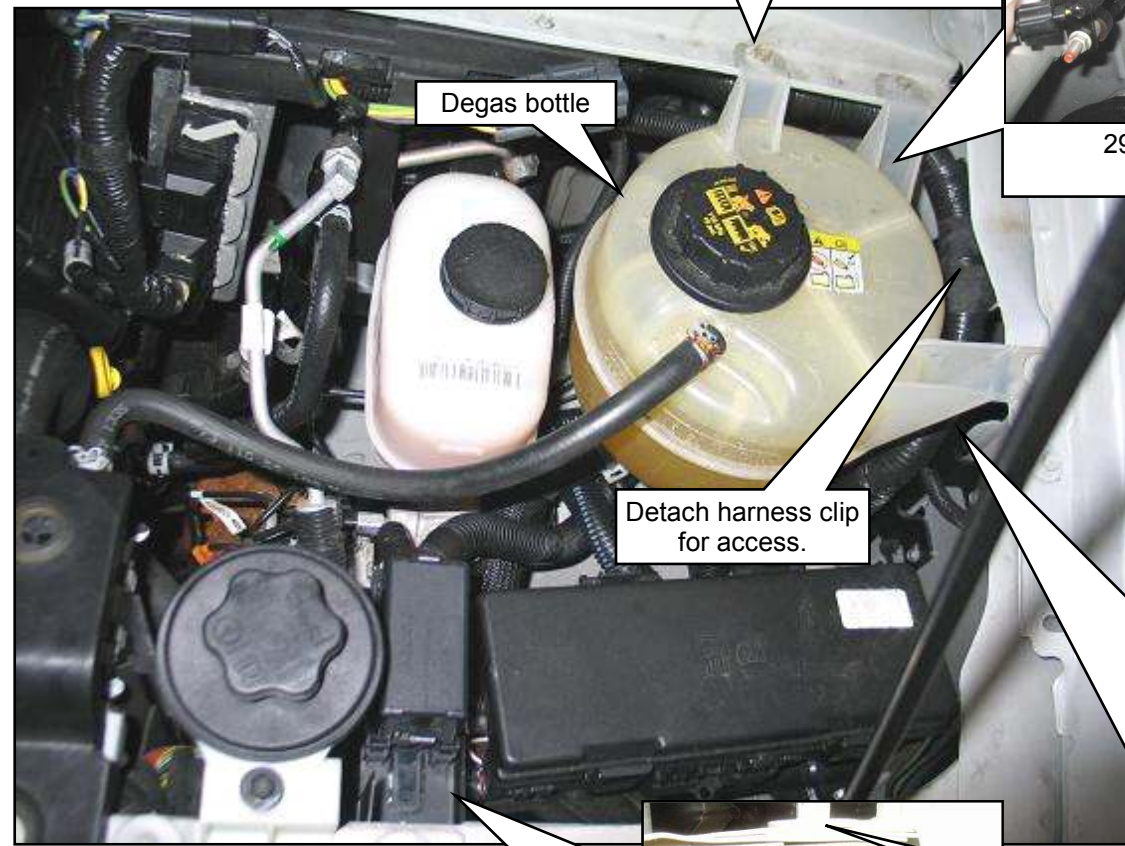

2. Drill a 29 mm (1-1/8") hole in dash panel to the right of the master cylinder and controller area network (CAN) wiring harness pass-through (circular indent in sheet metal). Use care when drilling to avoid damaging wiring harness in cab interior behind panel. Use a 29 mm hole saw with a pilot bit extending NO MORE than 13 mm (1/2") beyond saw teeth and push drill no deeper than necessary to cut through metal panel.

3. Assemble SRM to SRM bracket using four M6 socket-head capscrews, washers and nylon-insert locknuts. Tighten nut until snug.

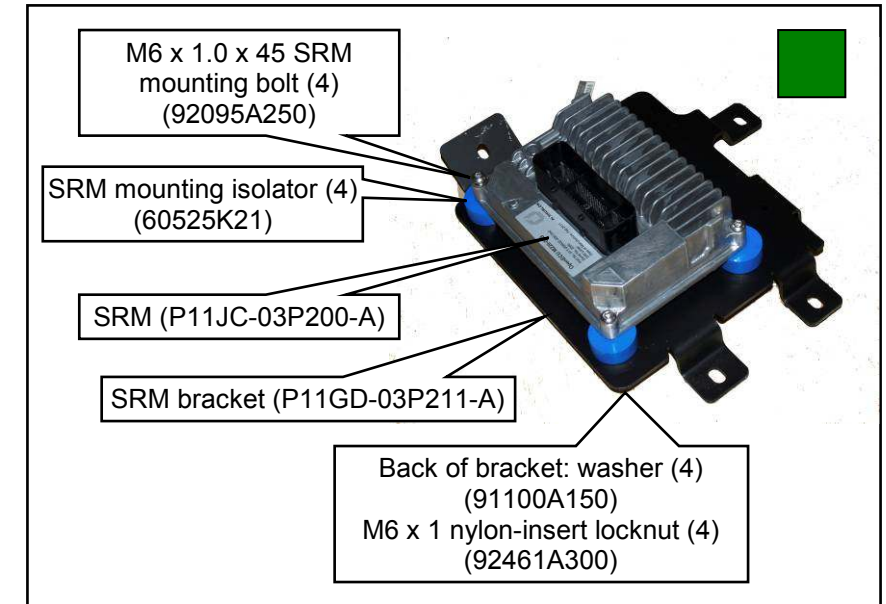

4. Remove retainer clip securing Ford wiring harness to inner fender and install one M6 x 1 J-clip in retainer hole.
5. Place SRM and bracket assembly in position on inner fender and install one M6 x 1.0 x 16 bolt in top rear hole (hole with J-clip).
6. Install an M6 x 16 self-tapping screw in each of three remaining mounting holes.



7. Install one M6 x 1 J-clip in hole at top of body flange (between fuse box and radiator).
8. Install auxiliary fuse box bracket with an M6 x 16 bolt in the top hole.
9. Drill a pilot hole and install an M6 x 16 self-tapping screw (91324A580) in lower mounting hole to secure bracket.

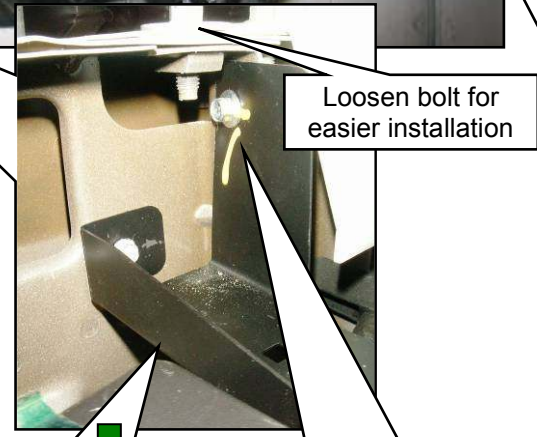

- A – M6 x 1.0 x 16 bolt (W500213-S437) ■
Tighten to 8–12 Nm.
- B – M6 x 16 self-tapping screw (91324A580) ■

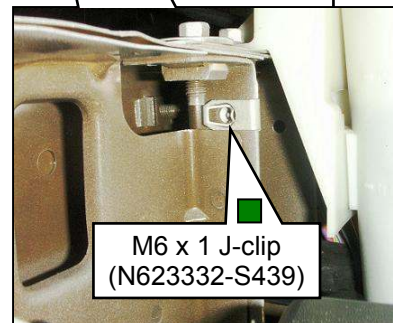
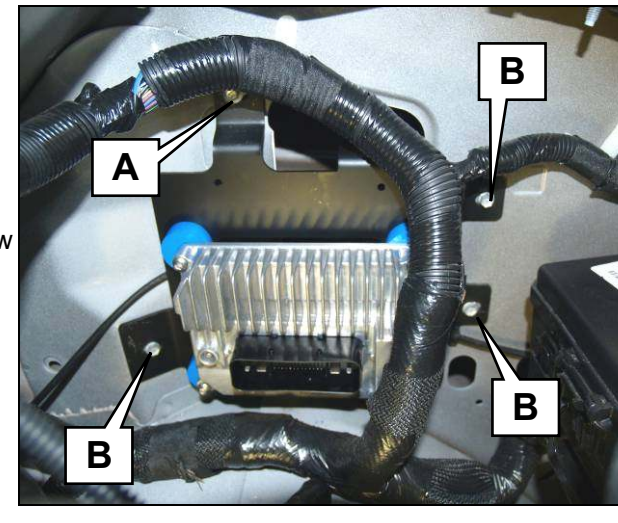

INSTALLING INSTRUMENT PANEL WIRING HARNESS

1. From passenger side of instrument panel, grasp instrument cluster finish panel at lower right corner and top and carefully pull back to release retention tabs. Carefully pull right side of panel back enough (approximately 76 mm) to gain access to connectors for completing these connections.
2. If vehicle is equipped with electronic trailer brake controller, disconnect harness from brake controller. On models not equipped with an electronic brake controller, an unused original wiring harness connector (A) is stowed in an area at right side of finish panel.

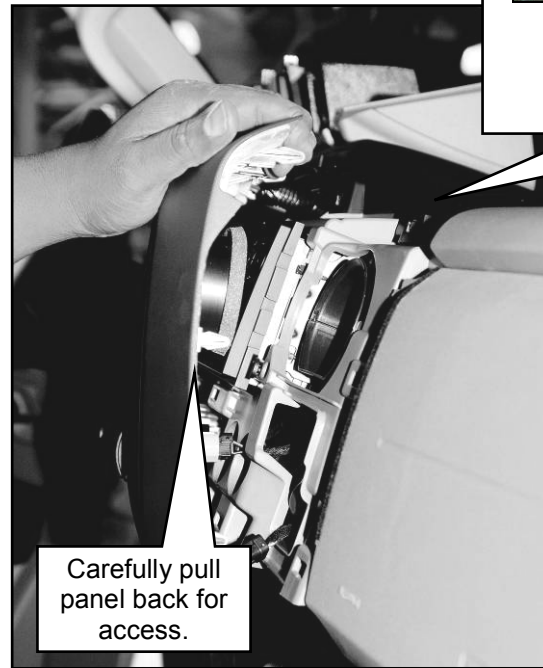
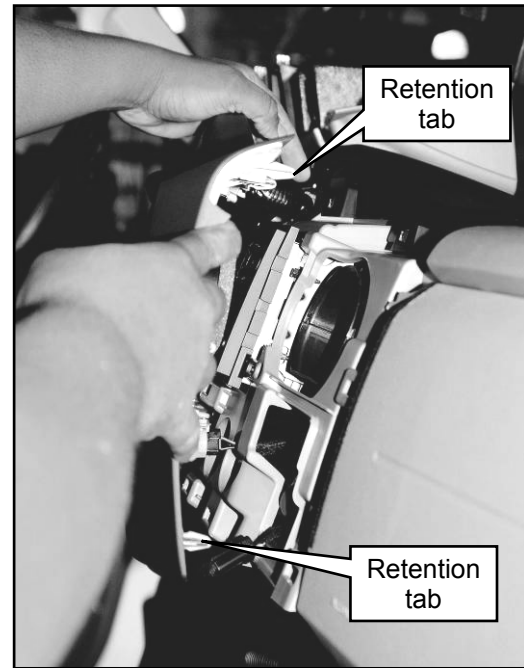
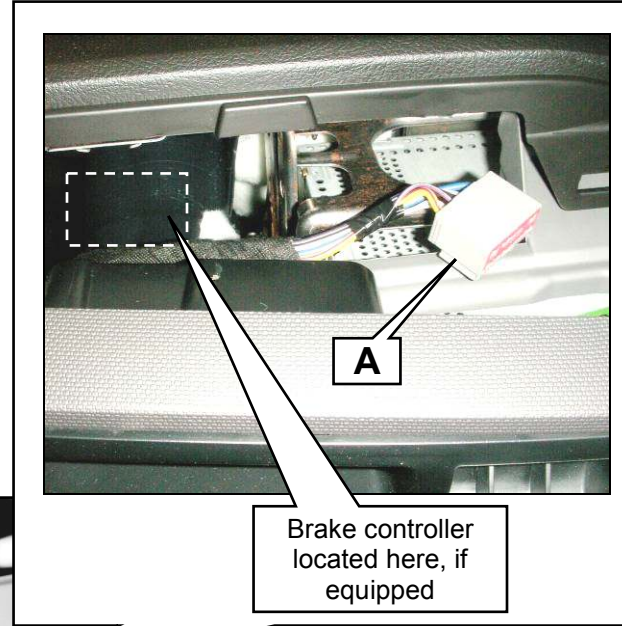

ROUSH CleanTech CAN harness connections

1. Connect terminal end (B) of CAN harness (P11GD-18B100-A) to vehicle harness connector (A).
2. Connect terminal end (C) to brake controller (if equipped) or stowed unused terminal end (C) in slot at back of instrument finish panel.

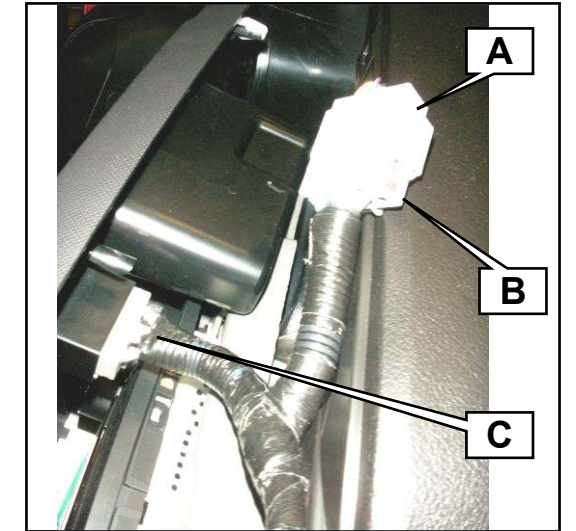

CAN harness routing to engine compartment

1. With connections to vehicle harness and brake controller complete, route harness end with single connector down behind finish panel and to area behind closeout panel under steering column. (Closeout panel must be removed to access this area along with on-board diagnostics (OBD) II diagnostic connector.)
2. Route CAN harness under steering column and over to newly drilled 29 mm pass-through hole. Use zip ties to secure CAN harness to original factory wiring harness.

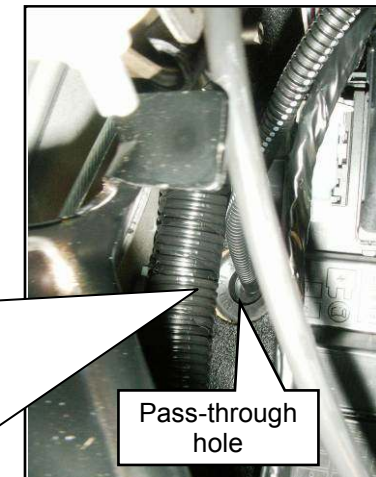
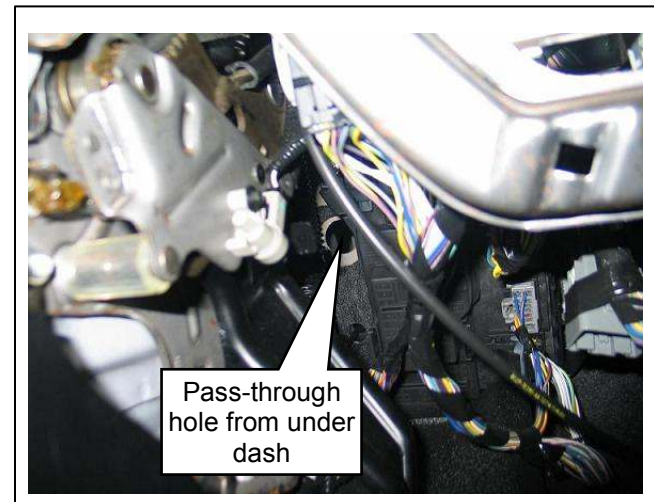
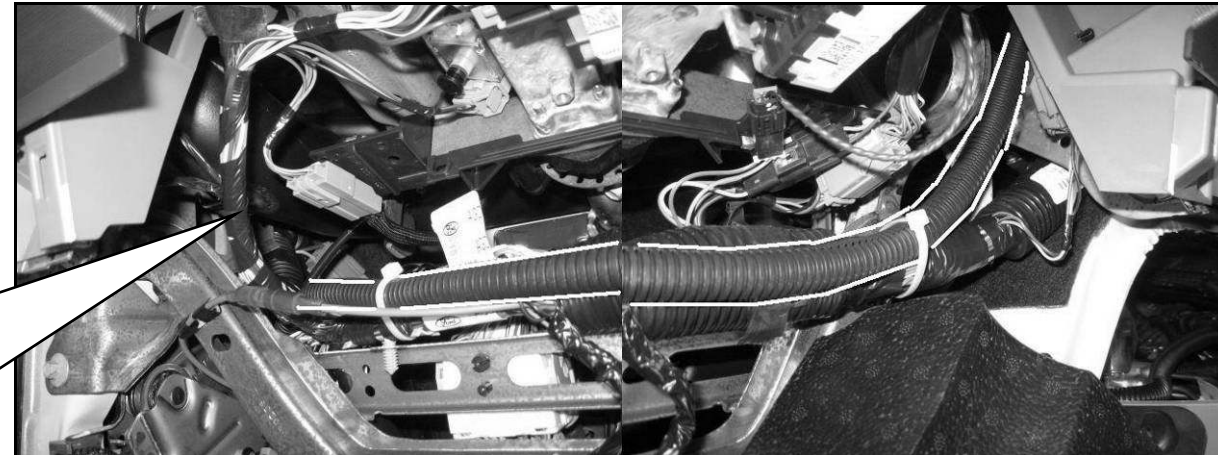

3. Insert CAN harness single-connector end through 29 mm pass-through hole into engine compartment. From engine compartment, carefully pull harness through dash panel until grommet is correctly seated in pass-through hole.
Note: See Instrument Underhood Wiring Harness for connecting CAN harness to underhood harness.
4. Install instrument cluster finish panel and closeout panel below steering column.

INSTALLING UNDERHOOD WIRING HARNESS

Note: All parts for installing ROUSH CleanTech underhood harness (P11GD-18A100-A) are in hardware kit P11JC-ELECKIT-A.

Note: It is recommended to route entire harness and make all connections prior to retaining harness with zip ties. Retaining harness with zip ties should be final step.

5. Install auxiliary fuse box (part of harness) on mounting bracket. Check that fuse box tabs are fully seated and locked in place. Add a zip tie to secure harness to bracket.
6. Open Ford fuse box and connect new underhood harness battery positive eyelet to positive post.

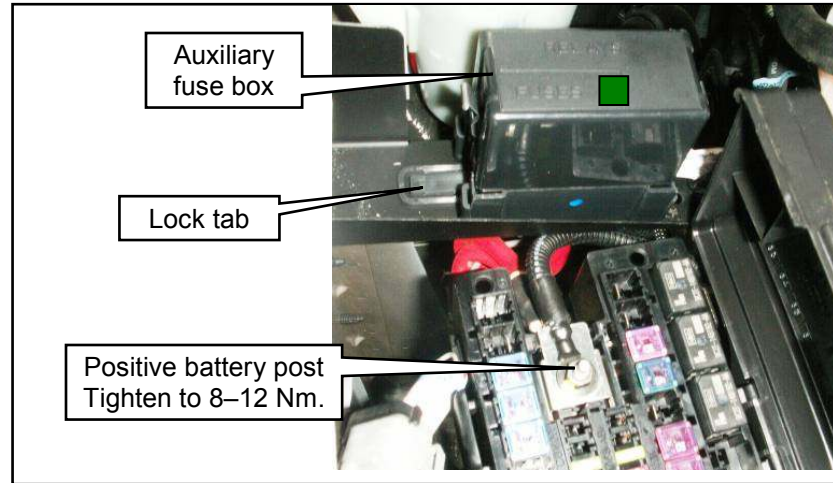

1. Connect underhood harness ground eyelet to existing Ford ground location on wheel well near SRM.
2. Attach underhood harness connector to SRM.
3. Connect CAN harness to underhood harness.

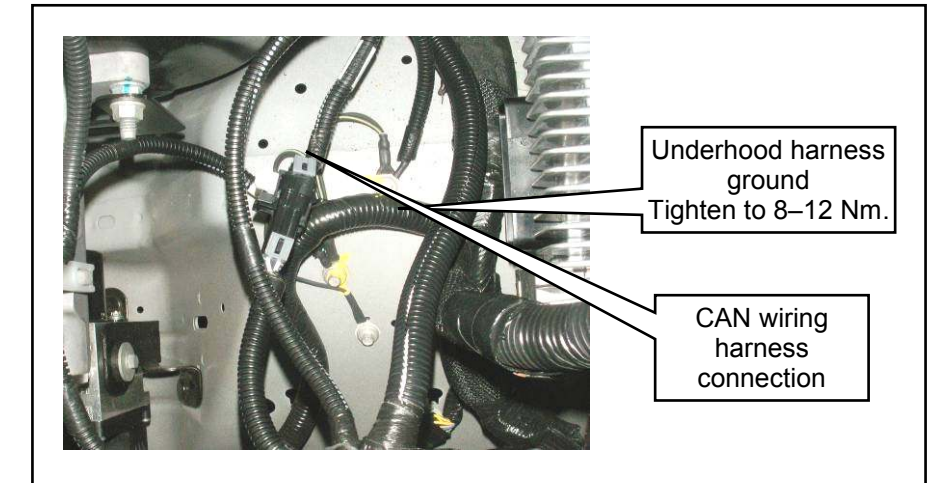

6. Plug fuel level interface module (FLIM) into underhood wiring harness. Use narrow tie strap (PLT21-MO) to secure FLIM to underhood harness.

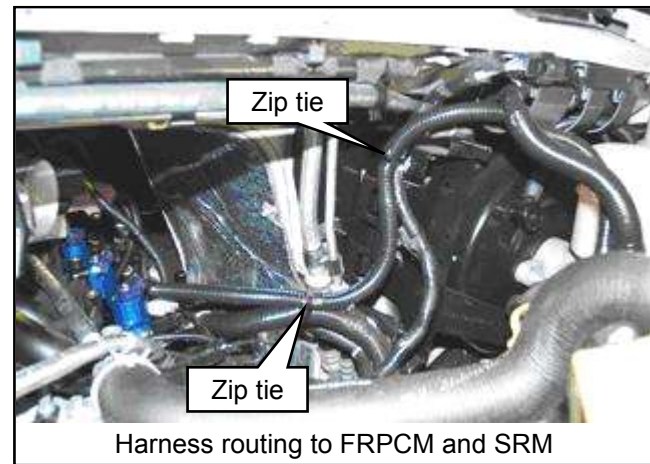

9. Route break out with FRPCM and SRM connectors along cowl above brake booster. Continue routing along left side of engine and make connections to FRPCM and SRM. Secure break out to Ford harness with zip ties.

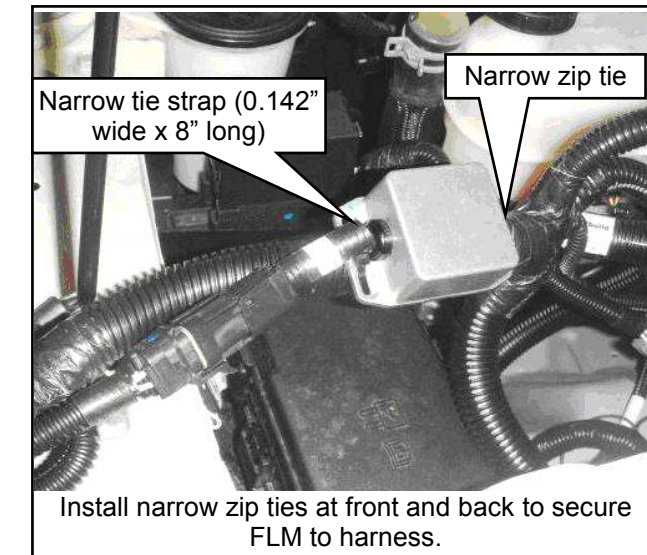
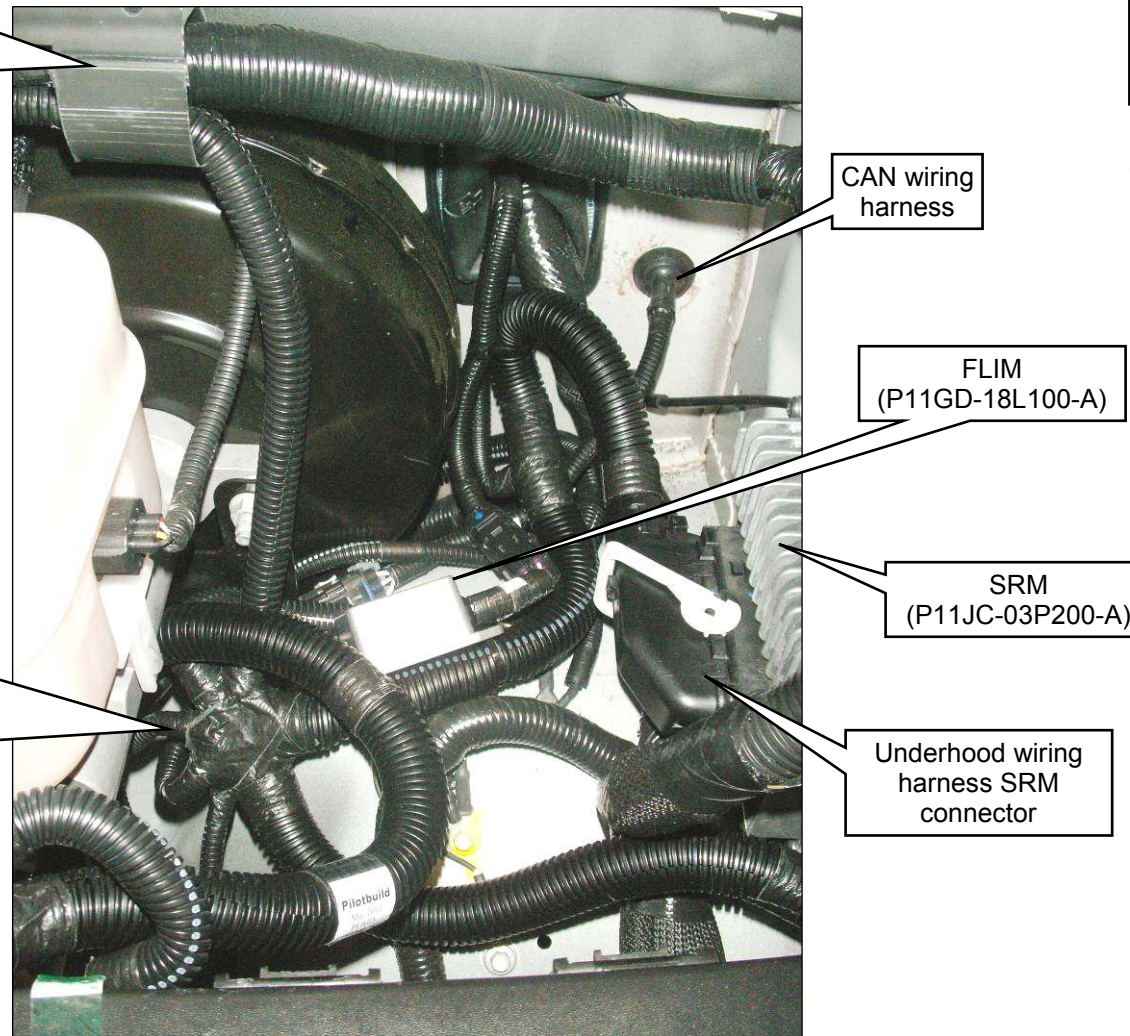
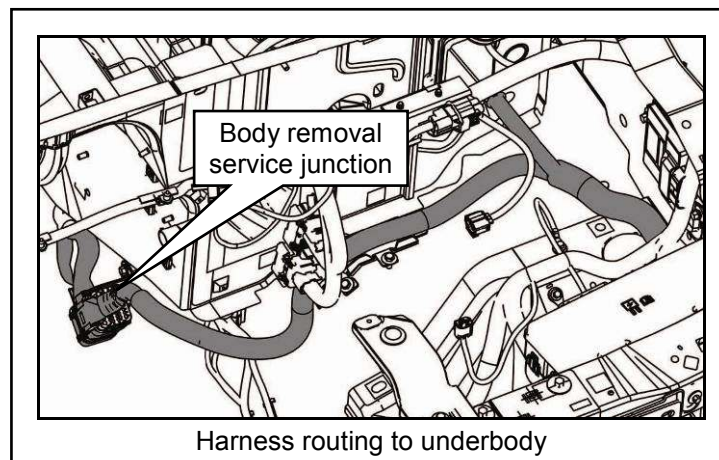

7. Route break out with 6-pin service connection under vehicle toward left frame rail, following Ford chassis harness.
8. Install degas bottle and tighten three fasteners to 8-12 Nm.

INSTALLING REAR FRAME WIRING HARNESS

1. Install new electronic fuel pump relay (EFPR) just rearward of original EFPR. Position new EFPR with electrical connector oriented rearward. Align the upper hole of the relay with frame rail hole, mark lower relay hole on frame rail and drill a 5/16" or 8 mm hole in rail. Use two spacers between EFPR and frame rail, position relay and install two M8 bolts and locknuts. Tighten to 8-12 Nm. These parts are in hardware kit P11JC-ELECKIT-A.
2. Install and route rear frame wiring harness along original vehicle harness from underhood wiring harness along left frame to original EFPR at midway of frame rail. Do NOT secure harness with zip ties until all connections are made.
3. Connect rear frame wiring harness to both EFPRs and to OEM vehicle harness. Use zip ties to secure rear frame wiring harness to vehicle harness after installation and all connections are complete.
4. Connect rear frame wiring harness ground lead to frame using M6 bolt and nut. Tighten to 8-12 Nm.
5. Connect rear harness to underhood harness. Use zip ties to secure 6-pin and 2-pin harness connectors to vehicle harness inside frame rail.
6. Connect 4-pin harness connector to vehicle wiring harness.

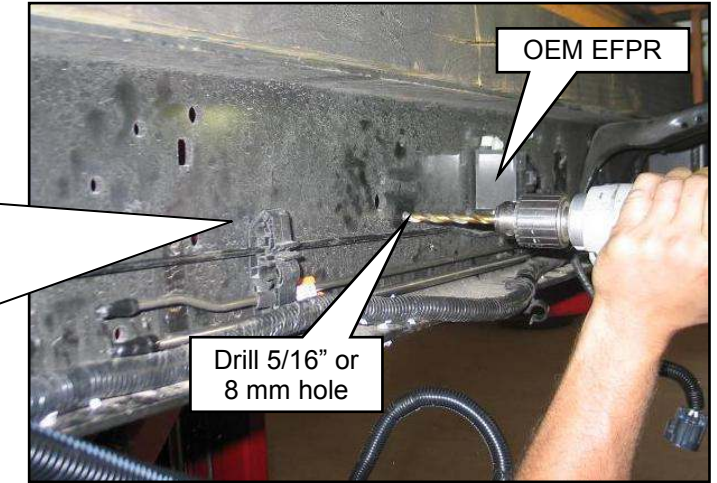
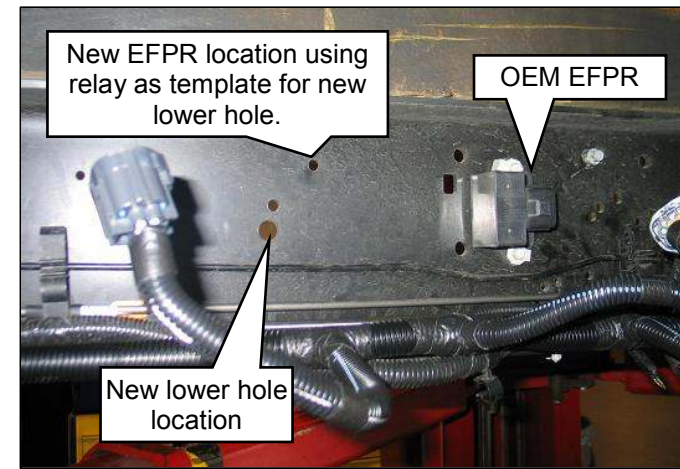

Three fuel tank connections are made during tank installation. Harness leads are secured to original vehicle harness inside frame rail.

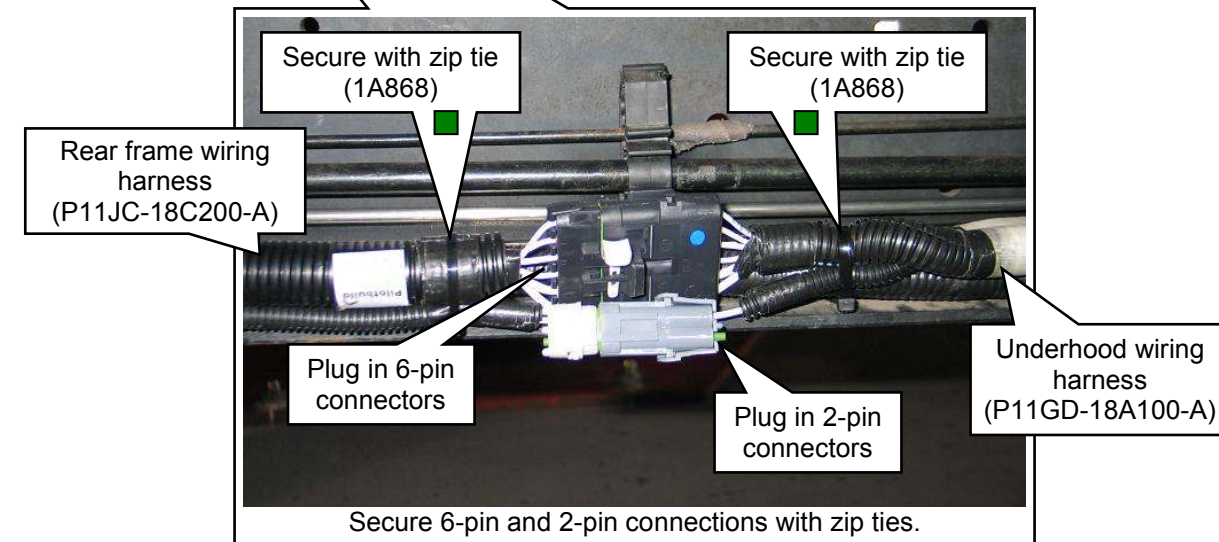
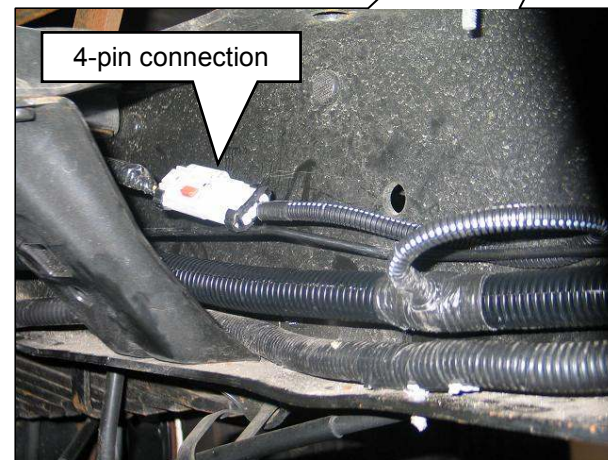
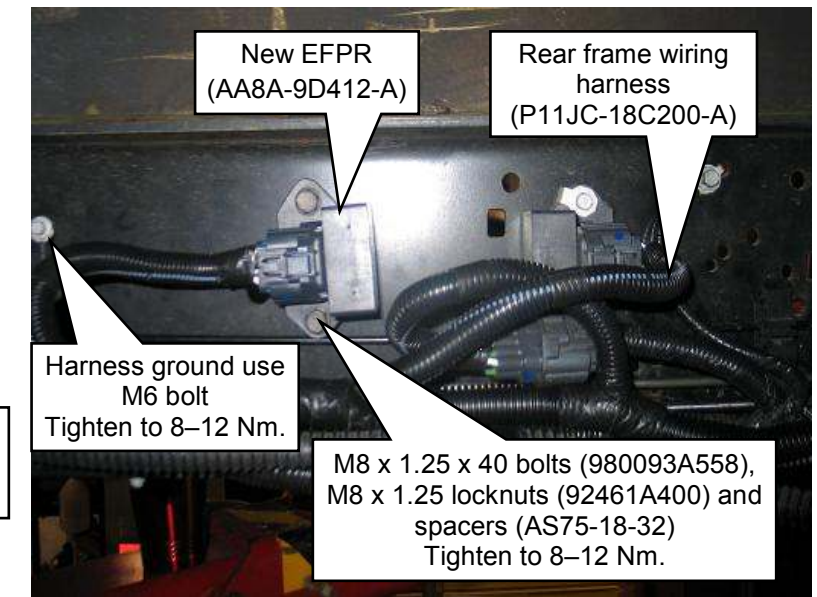
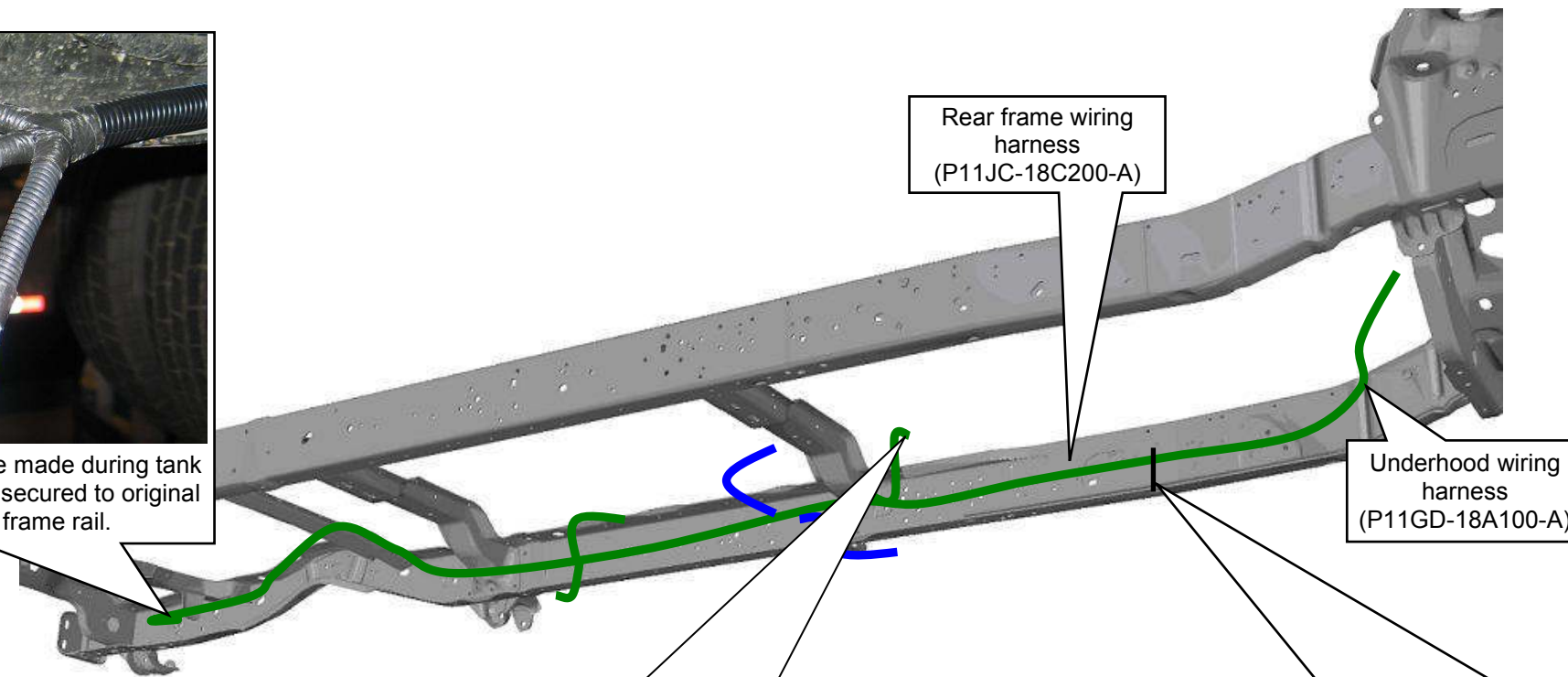

PLUGGING VAPOR CANISTER PORT AND SEALING FTPT CONNECTOR

1. If removed, install evaporative canister and bracket assembly, attaching it to frame rail and crossmember, following *Ford Workshop Manual, Section 303-13, Evaporative Emissions*.
2. Preassemble quick-connect fitting and vacuum cap found in hardware kit P11JC-FUEL1-A.
3. Install assembly on vapor canister port.
4. Install retainer clip to secure vehicle wiring harness as necessary.
5. Connect vehicle harness connector to evaporative canister vent solenoid. Use zip ties as needed.
6. The rear frame wiring harness includes a connector lead for a fuel temperature pressure transducer (FTPT). This lead is not used on E-450 Liquid Propane Autogas vehicles and requires connector end be sealed and secured:
 - Pack connector terminals with Ford dielectric grease, or equivalent.
 - Seal open end of connector with electrical tape.
 - Use zip ties to secure rear wiring harness and FTPT connector to Ford vehicle harness.

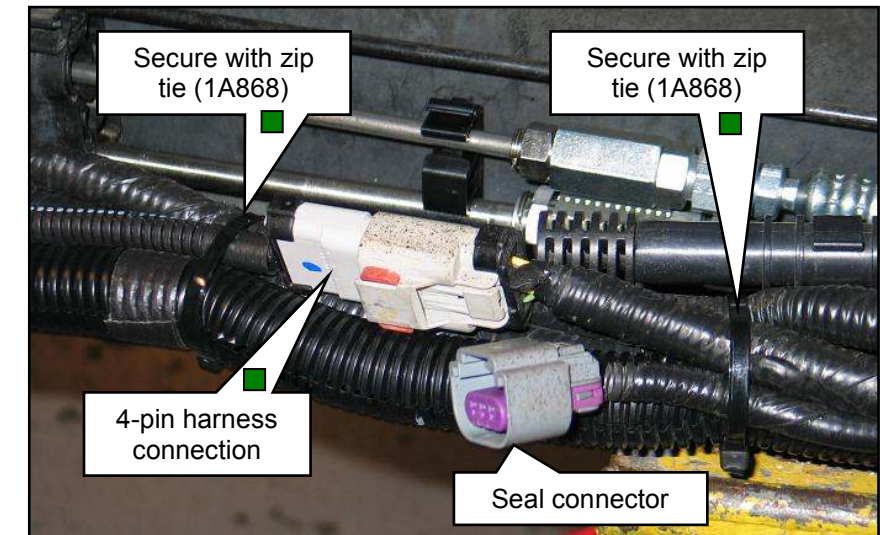
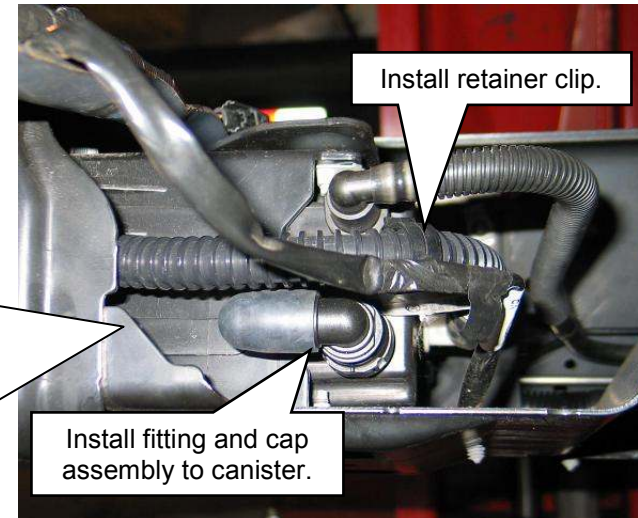
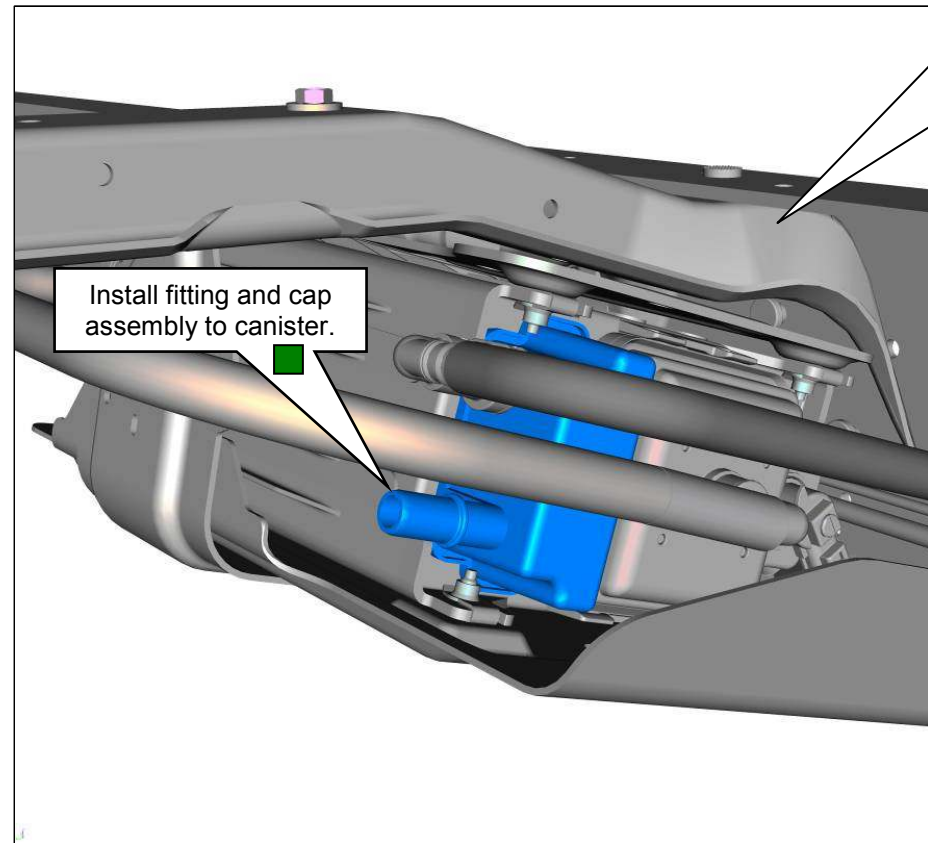
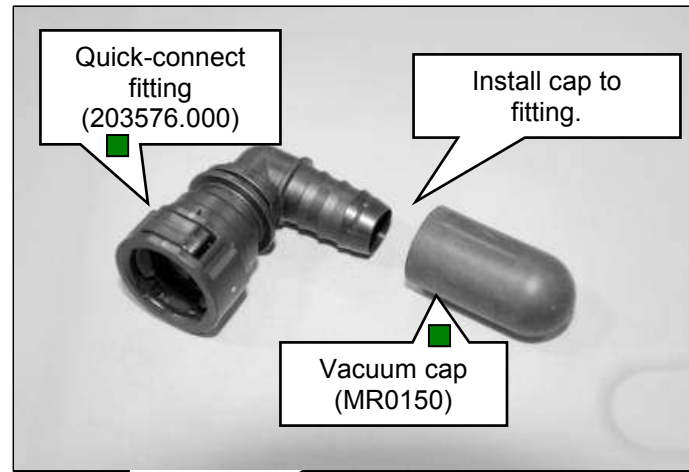

PREPARING THE TANK

1. Install supply solenoid and sender harness through supply valve cover hole at bottom.
2. Plug harness connector into supply solenoid and work harness grommet into opening until seated.
3. Secure shorter leg of harness to in-tank harness with two zip ties.
4. Run harness up side of tank to align with weld brackets and secure with zip ties.
5. Route harness over top end of left fuel tank, over to upper tank-to-tank bracket and down between tanks to lower tank-to-tank bracket.
6. Secure harness to the upper and lower tank brackets using cable tie edge clips.
7. Route harness under lower tank bracket, between tanks, so that fuel sender connector ends at weld bracket.
8. Secure fuel sender connector using a zip tie.
9. Install convolute over fuel fill line (tank-to-filter), making sure to cover the entire braided portion of the line. Secure at both ends with zip ties.
10. Attach either end of fuel fill line, filter-to-tank to fill port on right tank and drape line over tank to prepare for tank installation. Tighten fitting to 53–61 Nm.

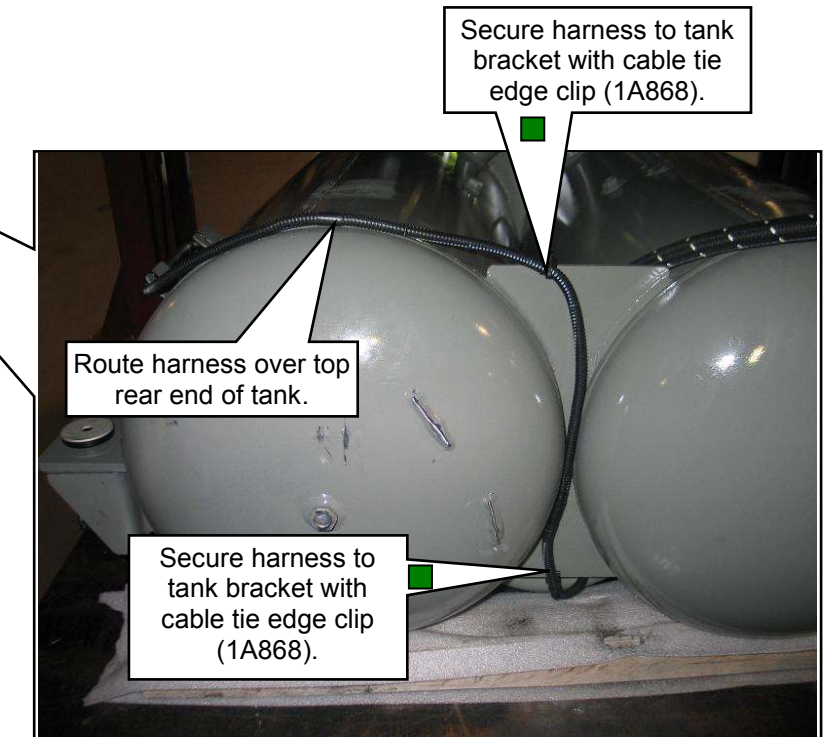
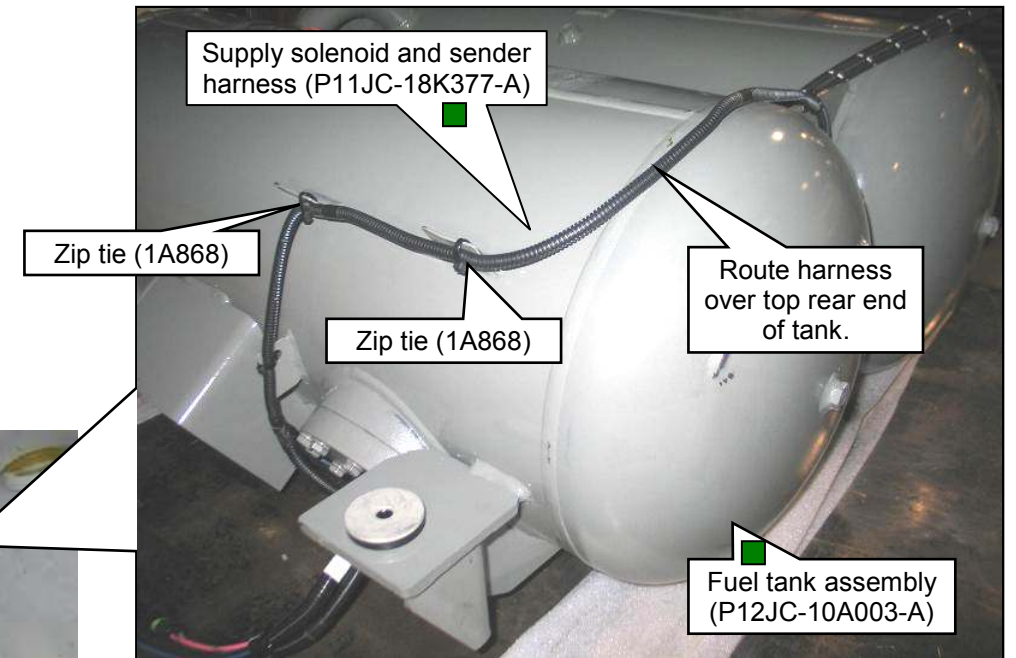
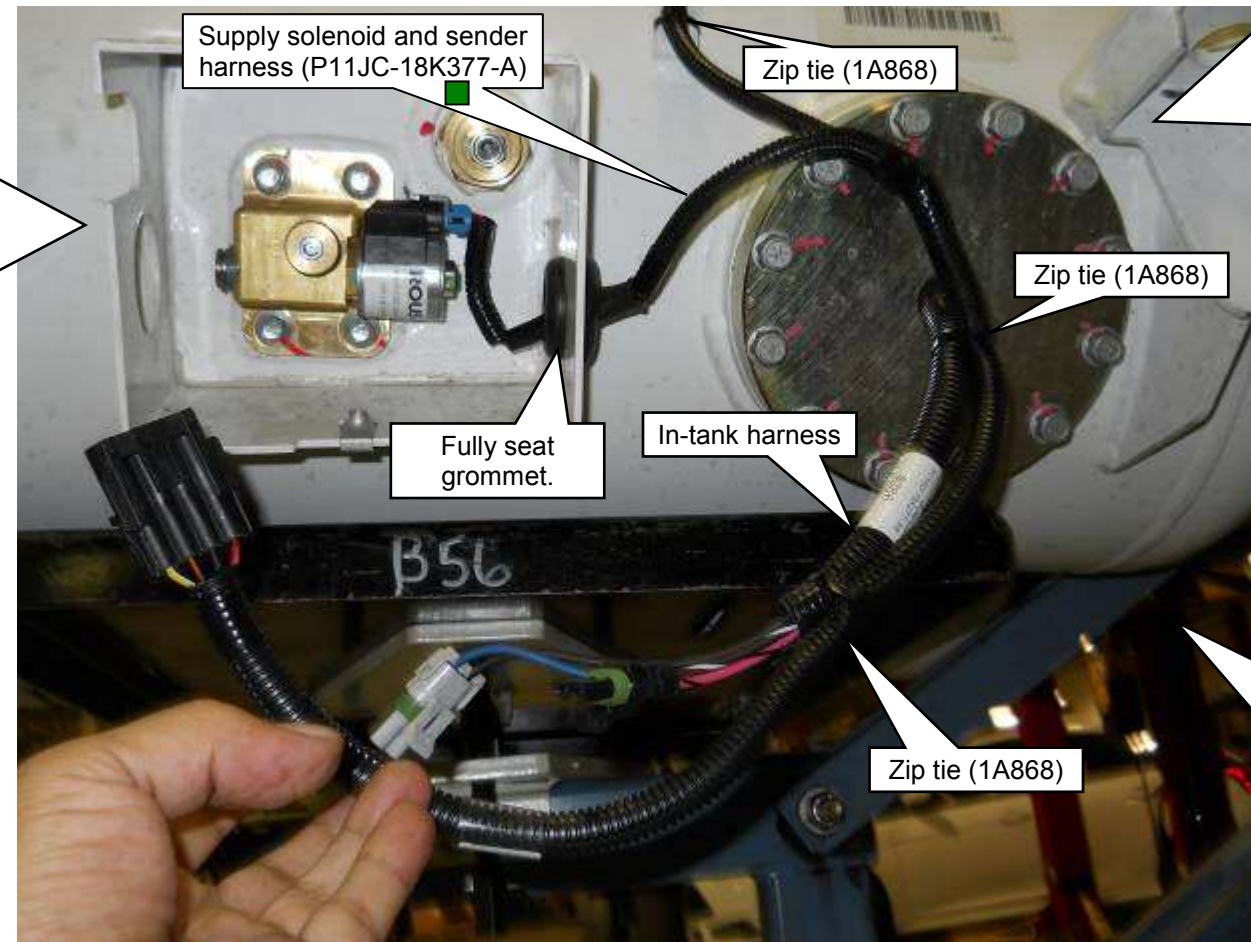
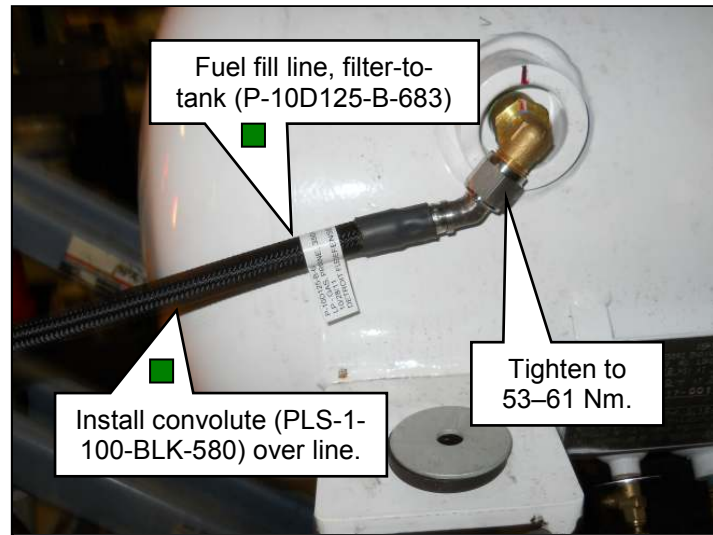

INSTALLING NEW FUEL TANK

Left-Hand Side

Install rubber isolators (2) (P07L3-9N052-A) above brackets.

Hold bolt and frame rail washer in frame hole when tightening nut.

Install washer (P07L3-3932-A) above rubber isolator at this location on LH side.

Install rubber isolators (2) (P07L3-9N052-A) above brackets.

Install rubber isolators (2) (P07L3-9N052-A) below brackets.

Install crushlimiters (2) (PBC2-11293-A) inside rubber isolators.

Install washers (2) (P07L3-3932-A) below rubber isolators at two locations.

M12 x 1.75 x 55 bolt (W709906-S439) Tighten to 100–110 Nm.

Left tank mounting bracket M12 x 1.75 nut (W710807-S440). Tighten to 100–110 Nm.

Right-Hand Side

Install washers (2) (P07L3-3932-A) above isolators at two locations on RH side.

Hold bolt and frame rail washer (2) in frame hole when tightening nuts.

Install rubber isolators (3) (P07L3-9N052-A) above brackets.

Install rubber isolators (3) (P07L3-9N052-A) below brackets.

Install crushlimiters (3) (PBC2-11293-A) inside rubber isolators.

Install washers (P07L3-3932-A) (3) below rubber isolators at all locations on RH side.

Right tank mounting bracket M12 x 1.75 nut (2) (W710807-S440). Tighten to 100–110 Nm.

Sleeve

Return port

Supply port

Harness grommet

Sleeve (P07L3-9C328-B) and zip tie (1A868)

Manual shutoff valve

Tighten thumb screw to secure cover.

Install lock.

Fuel pump harness connectors (2-pin)

Supply solenoid and sender harness connector (4-pin)

Fuel pump harness connectors (2-pin)

1. Raise fuel tank (or lower vehicle) so that tank is close enough to make the electrical connections. Connect three fuel tank harness connectors to rear frame wiring harness connectors. Install lock into 4-pin connector.
2. Install five rubber isolators on top of tank mount brackets. Place a washer onto each rear tank mount isolator and onto right side mid mount isolator. Install crush limiter into each rubber isolator.
Note: The front left and right isolators need no washers above the tank bracket.
3. Raise fuel tank into position against frame rails and front frame mount brackets. Leave tank slightly lowered until all bolts, washers, isolators, crush limiters and nuts are in place and started.
4. Install three nuts (one on left and two on right) to retain the hardware.
5. Install two front bolts through hardware and tank frame mounting brackets until started.
6. Raise tank to compress hardware against frame rails and tighten all fasteners to secure tank.
7. Tuck wiring harness and connections up between rail and tank.
8. Install rear fuel return line quick-connect into return port. Install fuel supply line quick-connect into supply port.
9. Install EPDM sleeves over fuel lines. Secure fuel supply line sleeve with zip tie.
10. Install cover over supply valve enclosure and tighten thumb screw to secure.

INSTALLING FUEL FILL LINE, TANK-TO-FILTER

1. Route the fuel fill line, tank-to-filter over the rear crossmember and to the fuel filter. **Note:** For alternate fuel filter location, route fuel fill line over to the fuel filter at the top inside of the crossmember. No clips or zip ties are required.
2. Attach fitting of line to fuel filter and tighten to 53–61 Nm at filter and at tank fitting.
3. Secure fuel fill line to crossmember using a cable tie edge clip.
4. Secure fuel sender harness to tank with cable tie edge clip and zip ties.
5. Connect fuel sender harness connector to fuel sender at bottom of right tank.

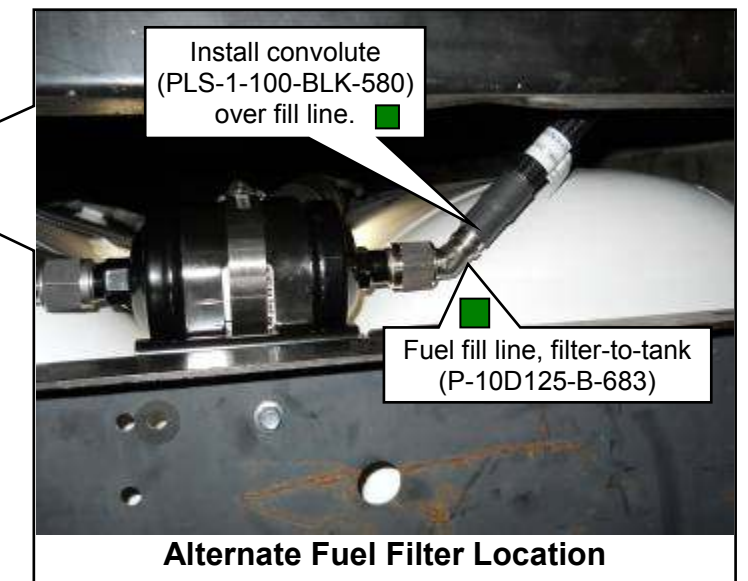
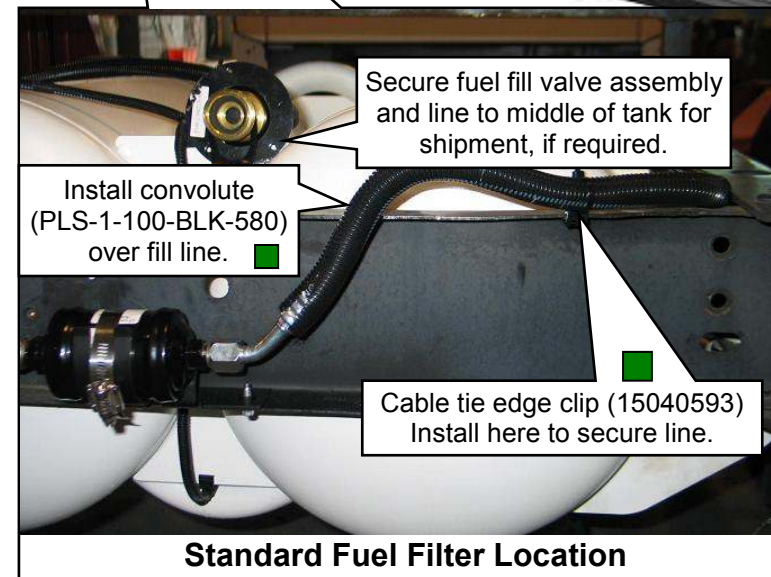
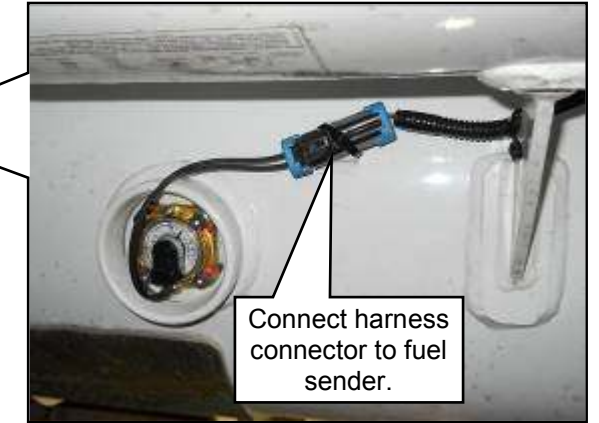
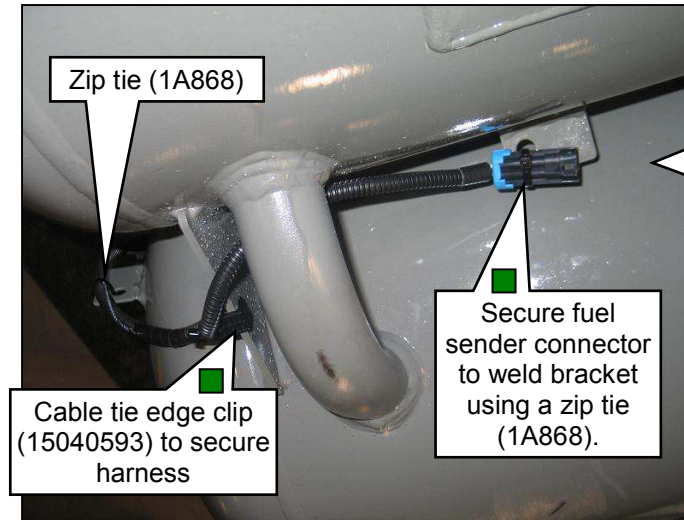
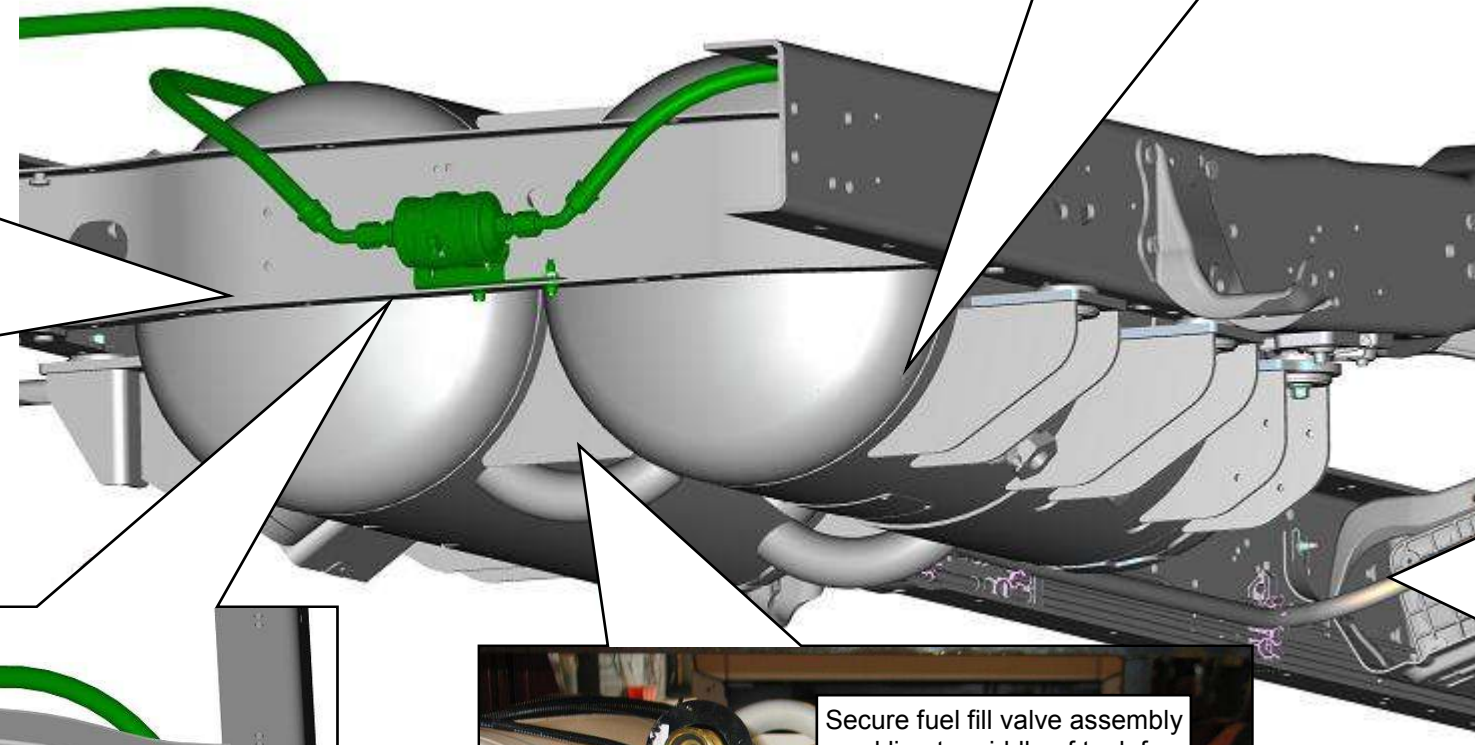
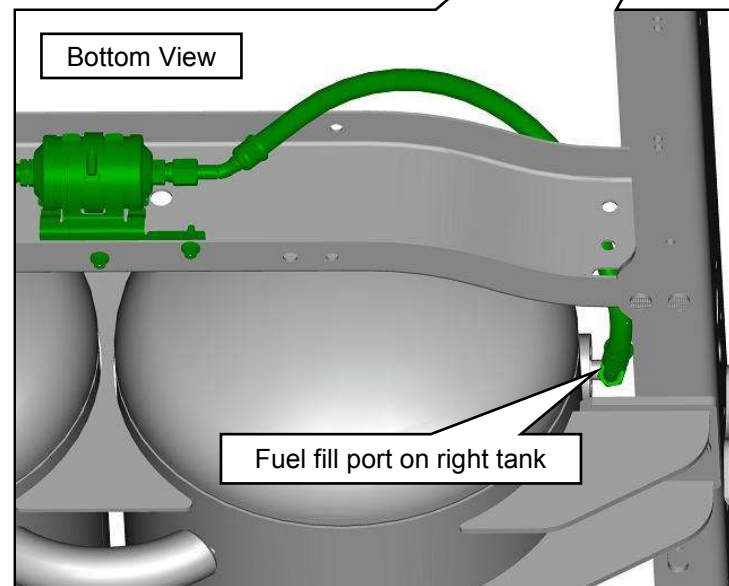
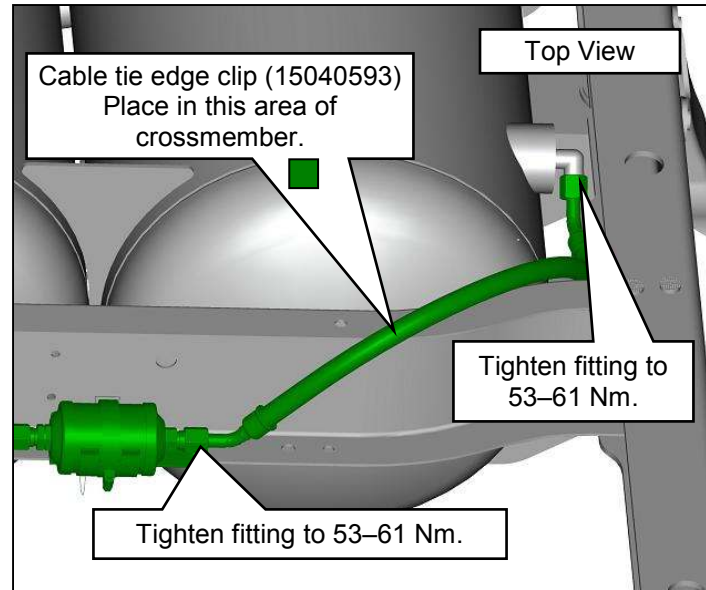

INSTALLING BADGES AND LABELS AND COMPLETING THE KIT INSTALLATION

Badges and Labels

1. To prevent damage, label and badge installation should be performed in an environment with temperatures above 60°F. Clean and dry the area on the vehicle where labels will be placed. All labels are found in hardware kit P11GD-LABLES-A.
2. Apply labels in locations shown.
3. Apply the ROUSH CleanTech VECI label to the location specified in the supplemental instructions included with the returned PCM. **Note:** These labels are vehicle-specific and are required by law to be applied to the vehicle to which they are assigned. Use the labels included with the PCM when returned to you by ROUSH CleanTech.

PCM Tamper Label (R07100008-10-A)

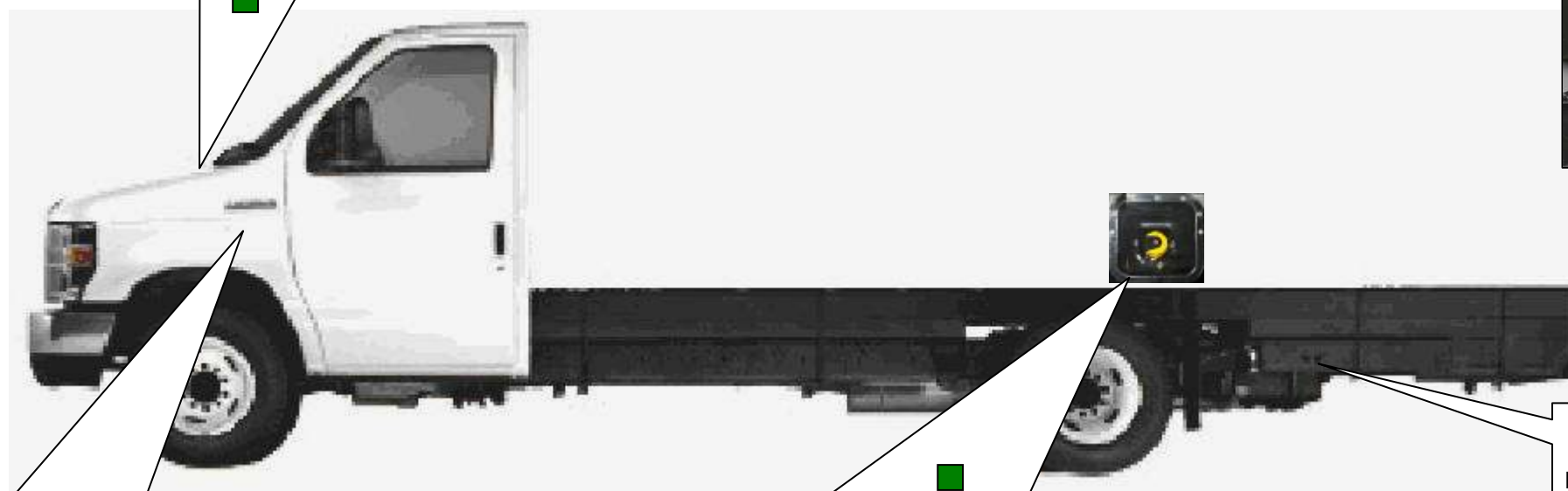

Diamond Propane Reflective (D85) on right rear



Fuel Tank Information Label (P11JC-10A900-A)
Bleeder Valve Inspection Label (P07L3-9A095-C)

ROUSH CleanTech Logo Dome Label (P11GD-01G100-A)
Refer to ROUSH CleanTech Badge Installation on page 25.



Apply 350 psi design pressure label (P07L3-9A095-I) here.

Apply propane fuel only label (P07L3-9A095-A) here.

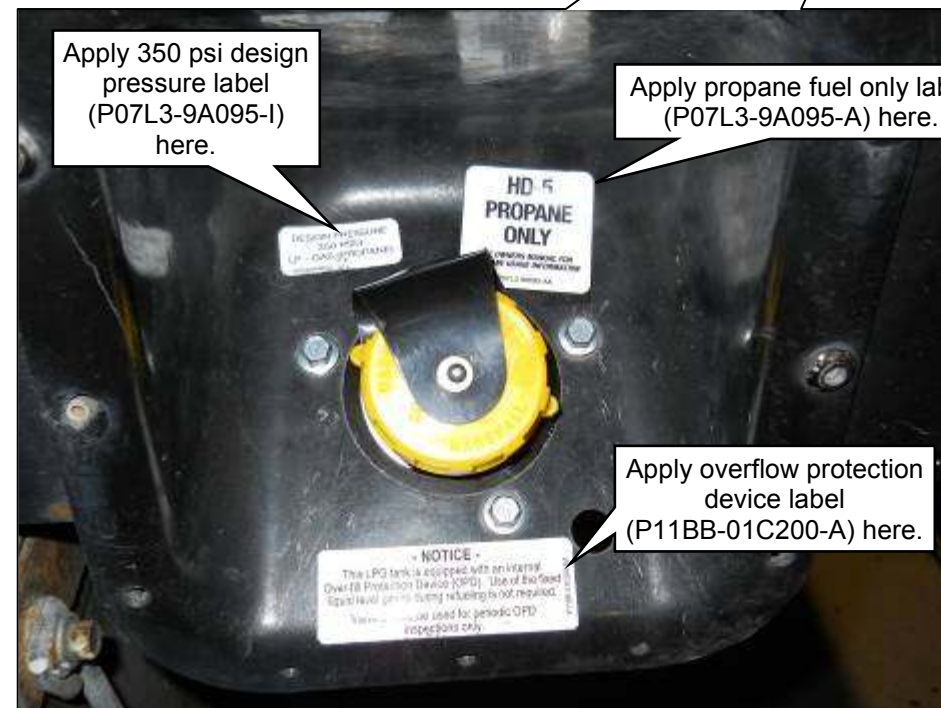

Apply overflow protection device label (P11BB-01C200-A) here.

Completing the Kit Installation

1. If not done, install the left exhaust heat shield over the left catalytic converter.
2. Install reprogrammed PCM following procedure in the *Ford Workshop Manual, Section 303-14, Electronic Engine Controls*.
3. Install vehicle battery and connect positive and negative terminals. Tighten to 8–12 Nm.
4. Perform system leak check following established ROUSH CleanTech procedure.
5. Install air induction system.
6. Connect MAF sensor.
7. Install radiator enclosure (cover). Install P-screws and tighten to 8–12 Nm. Or install push-pin retainers.
8. Install engine cover inside the passenger compartment. Latch the four latches.

ROUSH CLEANTECH BADGE INSTALLATION

Print this template on 11 x 17 paper set to landscape with scaling set to "None" or to "No Scaling" or original (actual) size at 100%. Cut the template out of the page, and if necessary, save for reuse. Cut along the lines. Use non-marring tape to secure the template to the badge location on the left front fender where indicated by the instructions.

ROUSH CLEANTECH BADGE INSTALLATION TEMPLATE For E-450 Cutaway Custom Body Vehicles

1. Clean the badge bonding area using isopropyl alcohol with a lint free towel.
2. Wipe the bonding surface dry immediately with a dry, lint free cloth or allow the solvent time to flash off.
Note: The time between surface preparation and badge install must NOT exceed 20 minutes.
3. Using non-marring tape, secure this template to the driver-side left-front fender of the vehicle.
4. Remove the backing by pulling it back at approximately 180 degrees.
Note: The time prior to application of the badge must NOT exceed three minutes.
Note: Avoid finger contact with the adhesive surface of the badge at all times.



The logo consists of the word "ROUSH" in a large, bold, outlined font. Below it is a thick horizontal line, and below that is the word "CLEANTECH" in a smaller, spaced-out, outlined font.

5. Locate the badge to the body using the template for alignment.
Note: Application of the badge should be done between 60–90°F (16–32°C).
6. Remove the carrier strip by pulling it back at an angle of approximately 180 degrees.
7. Pressurize the badge by applying consistent and uniform force over the entire surface of the badge, including a minimum of three seconds of dwell time.
Note: If available, use a roller, a bladder or a bladder roller for best results.
8. Remove the template.

SCHEMATIC — ROUSH FUEL SYSTEM

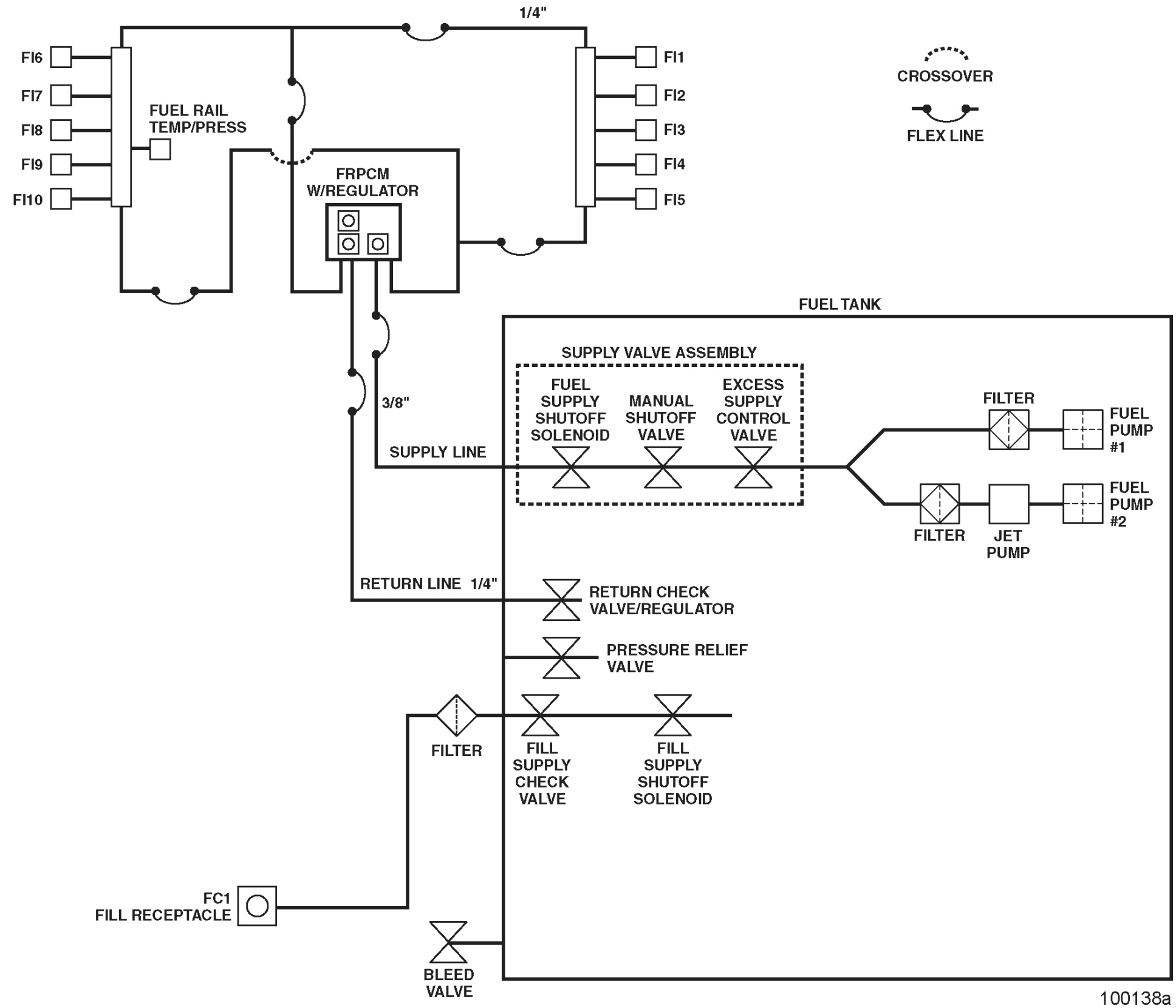

SCHEMATIC — ROUSH WIRING HARNESS

Note: This wiring harness print does not include the attachment locations for the ROUSH CleanTech in tank harness or the supply solenoid and sender harness at the rear of the vehicle.

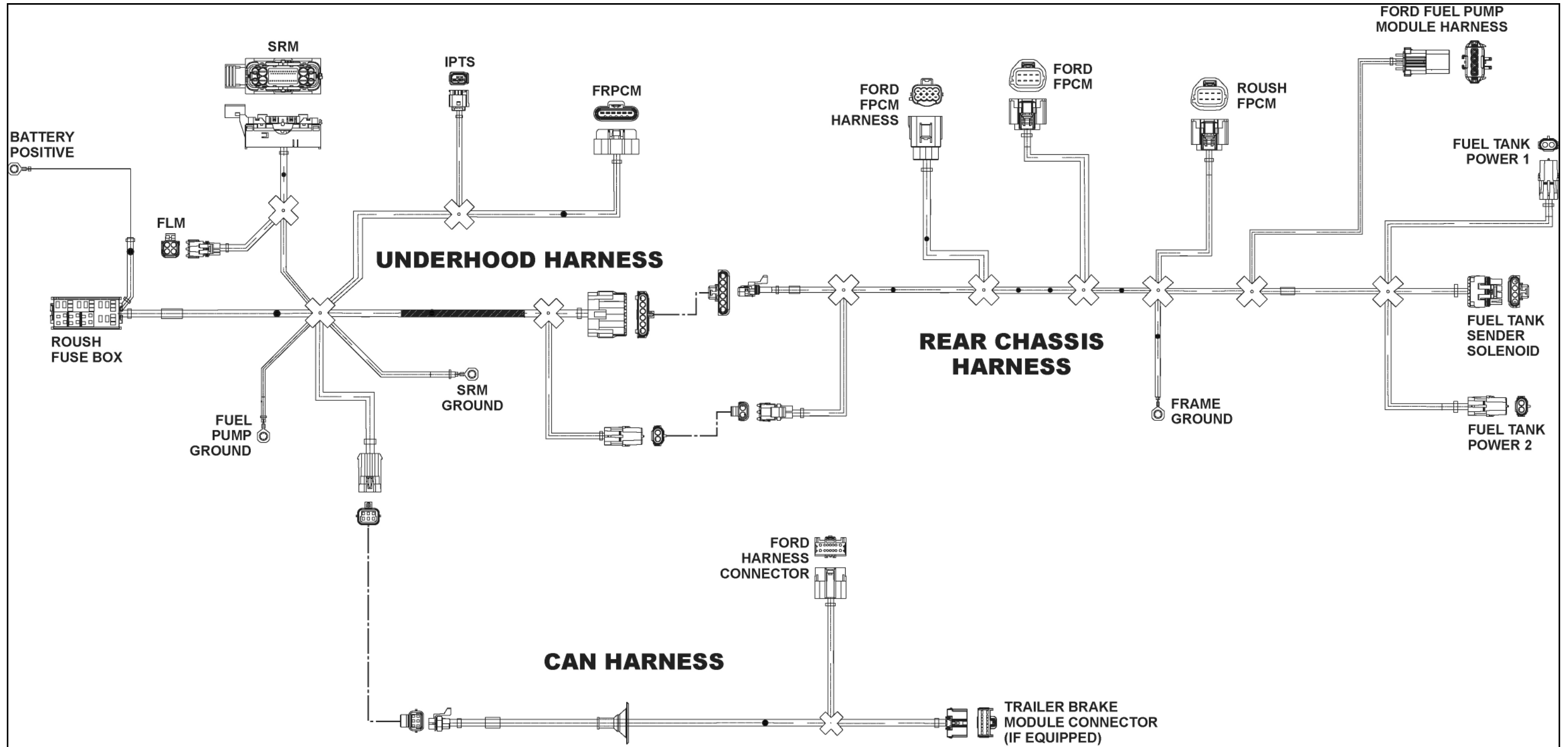

SPECIAL TOOLS



Touch-Up Paint

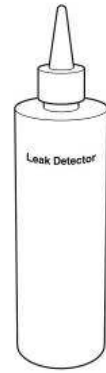

Liquid Leak Detector

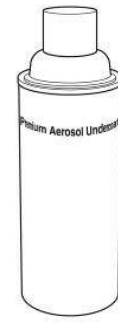

Premium Aerosol Undercoating

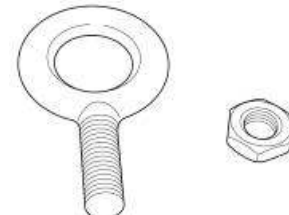

Eyebolt and Locknut, 5/8"-11



Fitting/Coupling

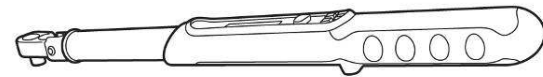

Torque Wrenches (22 Nm and 200 Nm)



Gloves (Approved for Propane)



Vacuum Pump (3CFM or 7CFM)



Scan Tool



Jiffy-Tite Disconnect Tool (1/4" and 3/8")

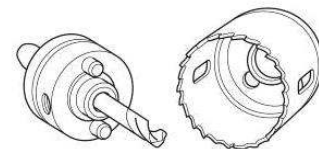

Hole Saw - 29 mm

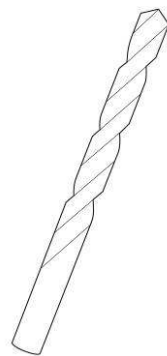

Drill Bits - 1/4", 5/16" and 15 mm

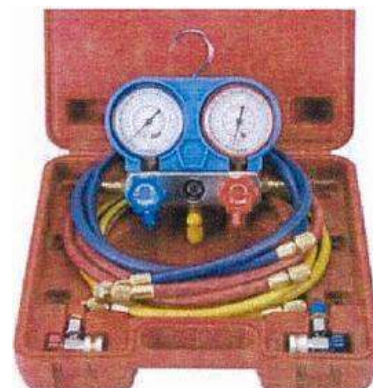

A/C Manifold Gauge Set



Vacuum Gauge

Fuel Filter Bracket Locating Templates

Standard Location

A new hole must be drilled in the rear crossmember so that the fuel filter bracket can be attached. This template is actual size.

1. Place template against bottom of fuel filter bracket and trace as shown.
2. Mark existing and new hole locations on template.
3. Place template under crossmember and align with front edge of crossmember.
4. Center punch location of new hole and drill 1/4" hole.

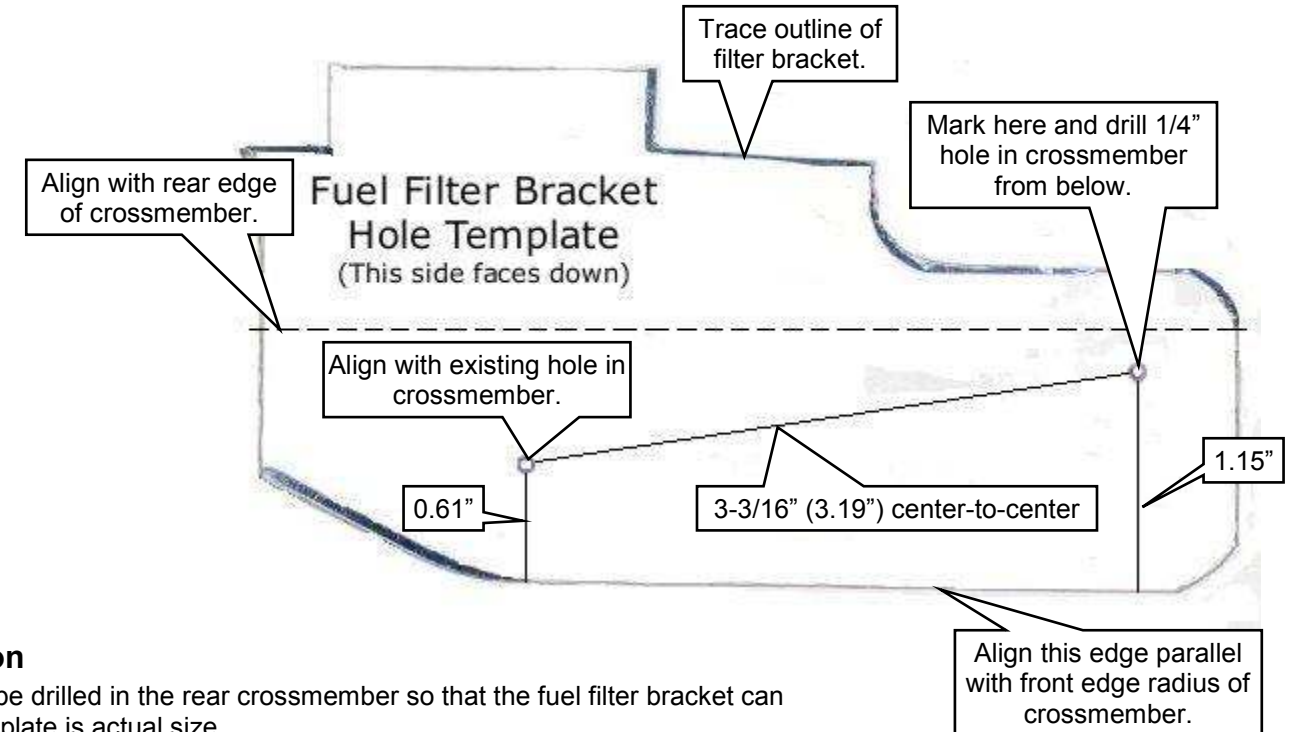

Alternate Location

Two new holes must be drilled in the rear crossmember so that the fuel filter bracket can be attached. This template is actual size.

1. Cut out template.
2. Place template against inside top of rear crossmember and mark new hole locations.
3. Center punch locations of new holes and drill holes to 1/4".

