



2010

Ford E-150/250/350

LIQUID PROPANE AUTOGAS

December 14, 2010

REV. April 26, 2011

KIT INSTALLATION INSTRUCTIONS

**ROUSH CleanTech E-150/250/350 Liquid Propane Autogas
2010 Kit Installation Instructions**

TABLE OF CONTENTS

INTRODUCTION	1	Removing the Original Filler Pipe	6
Safety	1	Removing the Original Fuel Supply Line	6
Alert Messages	1	Preparing the Engine Compartment	7
Limited Liability Disclaimer	2	Installing the New Fuel Rail Assemblies	10
Two-Person Procedures	2	Installing the New Wiring Harness	14
Stainless Steel Fuel Lines	2	Installing the New Fuel Fill System	22
Jiffy Tite Fuel Line End Connectors	2	Preparing the Tank Assembly	25
Threaded Fuel Line End Connectors	2	Preparing the Frame	32
Threaded Fasteners	2	Installing the Fuel Tank Assembly	35
Bare Metal Surfaces	2	Installing the New Forward Fuel Lines	41
Metal-to-Metal Contact	2	Attaching the Pressure Relief Hose and Attaching the Remote Bleeder Valve Line	48
Packaging	2	Installing the Reprogrammed PCM	48
Installation, Garaging and Training	2	System Leak Check	49
Purging and Venting (Tanks and Lines)	2	Installing Badges and Labels	50
ROUSH Technical Assistance	2	Completing the Installation	53
DISASSEMBLY AND INSTALLATION	3	TOOL LIST	53
Reprogramming the Powertrain Control Module ..	3	SCHEMATICS AND DIAGRAMS	54
Removing the Original Fuel Tank	5		

Part Number P10C2-RKITIM-AB

Copyright © 2011 ROUSH® CleanTech. All Rights Reserved.

ROUSH CleanTech E-150/250/350 Liquid Propane Autogas 2010 Kit Installation Instructions

Important Notice:

The engine will run only with propane as fuel when this installation is complete. Before replacing the gasoline system with the ROUSH Liquid Propane Injection system, provide a supply of HD5 liquid propane with which to fill the new tank.

Introduction

This manual is a guide for the installation of the ROUSH CleanTech kit for converting a 2010 Ford E-150/250/350 van equipped with the 5.4L 2V V8 engine to run on propane fuel. Only a few components are involved.

Before installing your liquid propane conversion kit, read the installation instructions and verify that all items in the packing list are present.

The liquid propane conversion kit is designed and tested to function properly only on Ford Motor Company vehicles as they are equipped from the factory (stock powertrain). The use of aftermarket parts and equipment such as cams, headers, nitrous oxide systems, other bolt-on performance parts, or any other performance parts not sold by, manufactured by, or approved in writing by ROUSH CleanTech for specific application to the 2010 E-150/250/350 van equipped with the 5.4L 2V V8 engine with a liquid propane conversion kit will result in powertrain damage and potential engine failure. ROUSH will not accept responsibility for such damage and failure.

The ROUSH CleanTech parts serve the same functions as the Ford parts they replace. The ROUSH CleanTech parts are designed for durability, reliability and economy in combination with liquid propane.

Propane, like gasoline, must be handled safely with knowledge of its characteristics. *Training in Basic Principles and Practices* developed by the Propane Education and Research Council (PERC), Washington, DC is available via an interactive DVD program at a modest price.

For most purposes in an automobile dealership, the basic course should be sufficient. Certification, if required, based on this material is also available, either on-line or through local facilities, at additional cost.





Safety

The National Fire Protection Association (NFPA) publishes a code book of rules that apply to the storage, handling, transportation and use of liquefied petroleum gas (LP-Gas or LPG). The book is known as **NFPA 58**. It is revised as necessary and published every other year. This code is adopted as law in virtually every political subdivision in the United States. Check with your local authorities for regulations applicable to liquid propane.

Observe all safety precautions provided in the Ford Motor Company Technical Services service information concerning the handling of the gasoline fuel system.

Alert Messages

The following alert messages appear from time to time in appropriate places in this manual. Ensure that all personnel in the immediate area are aware of these reminders.

-  **Danger:** — Although propane is nontoxic, nonpoisonous, has the lowest flammability range of any alternative fuel and dissipates quickly when released into the atmosphere, propane vapor is heavier than air and seeks the lowest point. When the ratio of propane to air is between 2.2% and 9.6%, propane will burn in the presence of an ignition source at 940°F (504°C) or hotter. Keep away from heat, sparks, flames, static electricity or other sources of ignition. Failure to heed this danger may result in severe personal injury or death.
-  **Danger:** — The fuel supply lines remain pressurized after engine shutdown. Keep away from heat, sparks, flames, static electricity or other sources of ignition. Do NOT enter storage areas or confined space unless they are adequately ventilated. Failure to heed this danger may result in severe personal injury or death.
-  **Danger:** — Do NOT carry lighted smoking materials or smoke while working on fuel system components. Failure to heed this danger could result in severe personal injury or death.
-  **Danger:** — Disconnect the battery ground at the battery to ensure that the vehicle electrical system has no current. Failure to heed this danger could result in severe personal injury or death.

ROUSH CleanTech E-150/250/350 Liquid Propane Autogas 2010 Kit Installation Instructions

LIMITED LIABILITY DISCLAIMER

The information in this publication was accurate and effective at the time the publication was approved for printing and is subject to change without notice or liability. ROUSH reserves the right to revise the information herein and to make changes and discontinue production of described parts at any time.

TWO-PERSON PROCEDURES

Removal and installation procedures take place under the hood and under the vehicle. The vehicle must be raised to permit working underneath. Installing the tank in under the vehicle requires the cooperation of two persons in conjunction with a hoist of at least 500 pound capacity.

STAINLESS STEEL FUEL LINES

Unlike Ford's, ROUSH CleanTech's fuel lines are constructed from stainless steel. Do **NOT** attempt to use the original fuel lines. Carbon steel corrodes more quickly in the presence of liquid propane.

JIFFY TITE FUEL LINE END CONNECTORS

Some of the ROUSH CleanTech fuel lines use a Jiffy Tite connection to aid in assembly. A special fitting is required to remove these lines once the connection has been made.

THREADED FUEL LINE END CONNECTORS

Also unlike Ford's, some of the ROUSH CleanTech fuel lines are equipped with threaded end connectors. Do **NOT** cross thread these connectors. Always tighten each connector by hand before applying a wrench to avoid cross threading.

THREADED FASTENERS

Hand tighten all threaded fasteners before applying a wrench to avoid cross threading.

BARE METAL SURFACES

You will be drilling holes through painted metal. Bare metal must be deburred and coated with a primer or sealer as specified in order to prevent rapid corrosion. The coatings must be allowed to dry before the affected parts are assembled.

METAL-TO-METAL CONTACT

There are locations where fuel lines pass closely to each other and to other metal surfaces. Do **NOT** allow direct contact between these parts. Apply EPDM sleeves to the fuel lines to prevent direct contact. Ensure that the sleeves cover the targeted areas.

Packaging

Carefully inspect the contents of the kit you receive to ensure that all parts are available before beginning installation. A parts list is enclosed with this manual. The list of parts varies with the van classification (E-150/250 vs. E-350).

Installation, Garaging and Training

Chapter 11, page 58-67, of **NFPA 58, 2008 edition**, applies to engine fuel systems using LP-Gas in internal combustion engines, including containers, container appurtenances, carburetion equipment, piping, hose and fittings and their installation. Additionally, this chapter applies to garaging of vehicles and to the training of personnel.

Paragraph 11.2 specifies that each person engaged in installing, repairing, filling or otherwise servicing an LP-Gas engine fuel system shall be trained. For additional information about the CETP E-Learning computer-based training program developed by PERC, contact Courtney Gendron at courtney.gendron@propanecouncil.org.

PURGING AND VENTING (TANKS AND LINES)

Venting of LP-Gas to the atmosphere is covered by paragraphs 7.3.1, General, and 7.3.2, Purging, on page 58-55 of **NFPA 58, 2008**.

Paragraph 7.3.2.2 reads as follows. "Venting of cylinders indoors shall only occur in structures designed and constructed for cylinder filling in accordance with (**NFPA 58, 2008**: paragraph) 6.5.1, Chapter 10 and 7.3.2.2(A) through 7.3.2.2(C). The following paragraphs are quoted from **NFPA 58, 2008**.

7.3.2.2(A) Piping shall be installed to convey the vented product outdoor at least 3 ft. (1 m) above the highest point of any building within 25 ft. (7.6 m).

7.3.2.2(B) Only vapors shall be exhausted to the atmosphere.

7.3.2.2(C) If a vent manifold is used to allow for the venting of more than one cylinder at a time, each connection to the vent manifold shall be equipped with a backflow check valve.

7.3.2.3 Venting of containers outdoors shall be performed under conditions that result in rapid dispersion of the product being released.

7.3.2.4 If conditions are such that venting into the atmosphere cannot be accomplished safely, LP-Gas shall be burned at least 25 ft. (7.6 m) from combustibles.

7.3.2.5 Venting of containers and burning of LP-Gas from containers shall be attended.

ROUSH Technical Assistance

Call ROUSH CleanTech customer service at **800-597-6874** with any questions regarding kit installation.

ROUSH CleanTech E-150/250/350 Liquid Propane Autogas 2010 Kit Installation Instructions

Disassembly and Installation

Special care should be taken to label the fasteners and parts taken off during this procedure that are to be reused.

- ▲ **Danger:** — The fuel supply lines remain pressurized after engine shutdown. Keep away from heat, sparks, flames, static electricity or other sources of ignition. Do NOT enter storage areas or confined spaces unless they are adequately ventilated. Failure to heed this danger may result in severe personal injury or death.
- ▲ **Danger:** — After de-pressurizing the gasoline system, disconnect the battery ground at the battery to ensure that the vehicle electrical system has no current. Failure to heed this danger could result in severe personal injury or death.

Reprogramming the Powertrain Control Module

▲ Caution

The Ford E-150/250/350 Powertrain Control Module (PCM; also called ECM, ECU, PCU or EEC) is programmed specifically for the vehicle using the vehicle identification number (VIN). It must be reprogrammed and returned to the vehicle from which it was removed.

Before removing the PCM and sending it to Roush CleanTech for reprogramming, a self-test diagnosis **MUST BE** performed and resulting error codes corrected.

Failure to heed this caution may result in improper function of the diagnostic and anti-theft programs.

- ▲ **Warning:** — Operating the engine without reprogramming by ROUSH CleanTech will result in engine damage or failure and will void all warranties.

ROUSH CleanTech provides the necessary PCM packaging, overnight transportation (each way) and reprogramming at no charge. Follow these steps to expedite the service.

1. Using a scan tool, check for all error codes. Correct all errors before continuing.
2. De-pressurize the fuel rail using the procedure described in Section 310-00, Fuel System, General Information, in the Ford Service Information Workshop Manual.
3. Remove the battery from the vehicle.
4. Following the procedure described in the Ford Service Information Workshop Manual, Section 303-14, Electronic Engine Controls, remove the powertrain control module (PCM). Disconnect the three (3) PCM connectors by lifting the grey levers over the connector back shell and lifting the connectors from their sockets (Part 1). Remove the two (2) nuts (Part 2) and position the PCM wiring harness aside. Remove the PCM (Part 3) from the vehicle by pulling the PCM forward and lifting it out of the engine compartment.

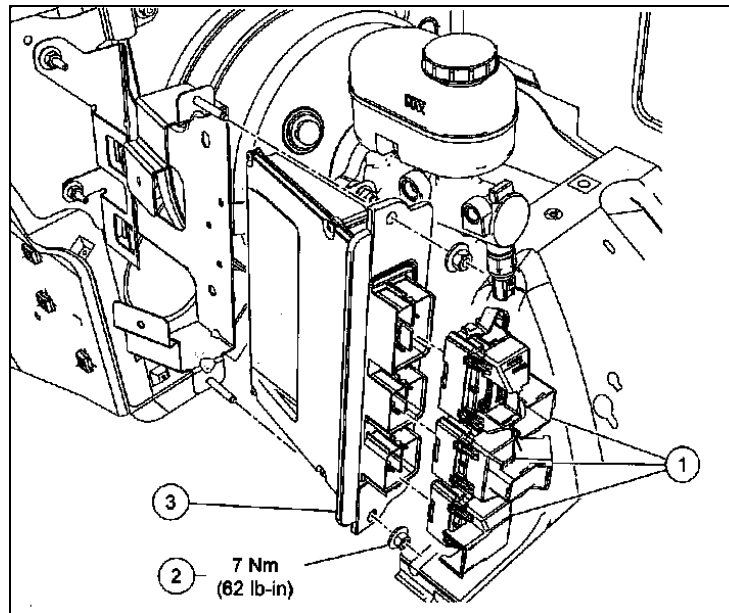

5. Install the Hang Tag Label (P07L3-9A095-KB) onto the rear view mirror of the vehicle.

ROUSH CleanTech E-150/250/350 Liquid Propane Autogas 2010 Kit Installation Instructions

6. Write the requested information, including the GVWR, on the PCM Return Label (P10C2-9A095-EA). The test group information will be found on the original VECI label. The propane fuel tank serial number can be found on the raised serial badge welded to the side of the tank. Once all information has been completed, apply the label to the back side of the PCM.

<p>ROUSH E-150/250/350 Propane PCM Label</p> <p>Purchaser's Full Name _____</p> <p>Purchaser's Address _____</p> <p>Vehicle Model Year _____ Mileage at Installation _____</p> <p>Vehicle Test Group _____</p> <p>Vehicle Identification Number _____</p> <p>BODY SERIES</p> <p><input type="checkbox"/> VAN <input type="checkbox"/> E-150</p> <p><input type="checkbox"/> WAGON <input type="checkbox"/> E-250</p> <p><input type="checkbox"/> E-350</p> <p><input type="checkbox"/> Hang Tag Installed <small>(Must be installed for PCM to be flashed)</small></p> <p>GVWR Front _____</p> <p>GVWR Rear _____ Tire Size _____</p> <p>Propane Fuel Tank Serial Number _____</p> <p style="text-align: right;">ROUSH.</p> <p style="font-size: small;">P10C2-9A095-EA</p>	<table border="1" style="width: 100%; border-collapse: collapse;"> <tr> <td style="text-align: center;"></td> <td style="text-align: center;">Ford Motor Company VEHICLE EMISSION CONTROL INFORMATION</td> </tr> <tr> <td colspan="2" style="text-align: center;">Conforms to regulations: 2008 MY FFV</td> </tr> <tr> <td colspan="2" style="text-align: center;">U.S. EPA: IT2B8 LDT4</td> </tr> <tr> <td style="text-align: center;">OBD: F II</td> <td style="text-align: center;">Fuel: Gasoline/Ethanol</td> </tr> <tr> <td colspan="2" style="text-align: center;">California: Not for sale in states with California emissions standards.</td> </tr> <tr> <td colspan="2" style="text-align: center;">TWC/HO2S/SFI No adjustments needed.</td> </tr> <tr> <td colspan="2" style="text-align: center;">5.4L-Group: 8FMXT05.44HF</td> </tr> <tr> <td colspan="2" style="text-align: center;">Evap: 8FMXR0250NBR</td> </tr> <tr> <td style="text-align: center;">▽8W7E-9C485-R R L</td> <td style="text-align: center; font-size: 2em; font-weight: bold; opacity: 0.5;">SAMPLE</td> </tr> </table>		Ford Motor Company VEHICLE EMISSION CONTROL INFORMATION	Conforms to regulations: 2008 MY FFV		U.S. EPA: IT2B8 LDT4		OBD: F II	Fuel: Gasoline/Ethanol	California: Not for sale in states with California emissions standards.		TWC/HO2S/SFI No adjustments needed.		5.4L-Group: 8FMXT05.44HF		Evap: 8FMXR0250NBR		▽8W7E-9C485-R R L	SAMPLE
	Ford Motor Company VEHICLE EMISSION CONTROL INFORMATION																		
Conforms to regulations: 2008 MY FFV																			
U.S. EPA: IT2B8 LDT4																			
OBD: F II	Fuel: Gasoline/Ethanol																		
California: Not for sale in states with California emissions standards.																			
TWC/HO2S/SFI No adjustments needed.																			
5.4L-Group: 8FMXT05.44HF																			
Evap: 8FMXR0250NBR																			
▽8W7E-9C485-R R L	SAMPLE																		

⚠ Caution: — Do **NOT** alter or remove the original VECI label from the vehicle. This label is required by law. Failure to heed this caution may void all warranties.

7. Using the bubble wrap provided, wrap the PCM securely and package it within the PCM Shipping Box (P10C2-SB-AA).
8. Enter your name and address in the **FROM** area of the shipping label provided with the box.
9. Peel off the label on the right side of the form and attach it to the outside of the shipping box in the indicated area. Retain the left side of the form for your records.
10. Call for a **FedEx** Package Pickup. Dial 1-800-463-3339, then 0, and speak to an agent in person. Do **NOT** use the automated option to schedule a pickup.
11. Inform the agent that you have a **FedEx Express Prepaid Stamp** package and request a pickup.

FedEx will deliver the package to ROUSH via overnight service. ROUSH will reprogram the PCM during the day in which it is received and return it to you via overnight service.

Included with the newly flashed PCM will be a ROUSH VECI label which must be affixed to the hood so that both the original and new labels can be read. Refer to the section "Installing Badges and Labels" for VECI placement.

ROUSH.	ROUSH INDUSTRIES VEHICLE EMISSION CONTROL INFORMATION
Conforms to regulations: 2010 MY	
U.S. EPA: T2B4 LDT4	OBD: FED OBD II Fuel: LPG
California: Not for sale in states with California emissions standards	OBD: N/A Fuel: N/A
TWC/HO2S/SFI	No adjustments needed
5.4L - Group: AR11D05.46VX Evap: AR11F0006LPG	▽P10C3-9C485-AA

SAMPLE

If you need to ship via another carrier, our address is:

**ROUSH Powertrain Development
Building 57
Attention: PCM Flash
777 Republic Drive
Allen Park, MI 48101**

If you have any questions, call ROUSH CleanTech customer service at 1-800-597-6874.

ROUSH CleanTech E-150/250/350 Liquid Propane Autogas 2010 Kit Installation Instructions

Removing the Original Fuel Tank

Refer to the Ford Technical Services, Service Information, Section 310-01, Fuel Tank and Lines, for complete instructions for removing the original fuel tank.

- ⚠ **Danger:** — Read and follow all applicable alert messages in the Ford manual. Failure to heed this danger may result in severe personal injury or death.
- ⚠ **Danger:** — The fuel supply lines remain pressurized after engine shutdown. Keep away from heat, sparks, flames, static electricity or other sources of ignition. Do **NOT** enter storage areas or confined spaces unless they are adequately ventilated. Failure to heed this danger may result in severe personal injury or death.
- ⚠ **Danger:** — Do **NOT** bring lighted smoking materials or smoke while working on fuel system components. Failure to heed this danger could result in severe personal injury or death.
- ⚠ **Danger:** — Disconnect the battery ground at the battery to ensure that the vehicle electrical system has no current. Failure to heed this danger could result in severe personal injury or death.

1. When removing the fuel tank, disconnect the forward section of the fuel tank-to-vapor canister supply line in location "A" shown below. The remainder of this line is affixed to the fuel tank and will come out of the vehicle with the fuel tank assembly.

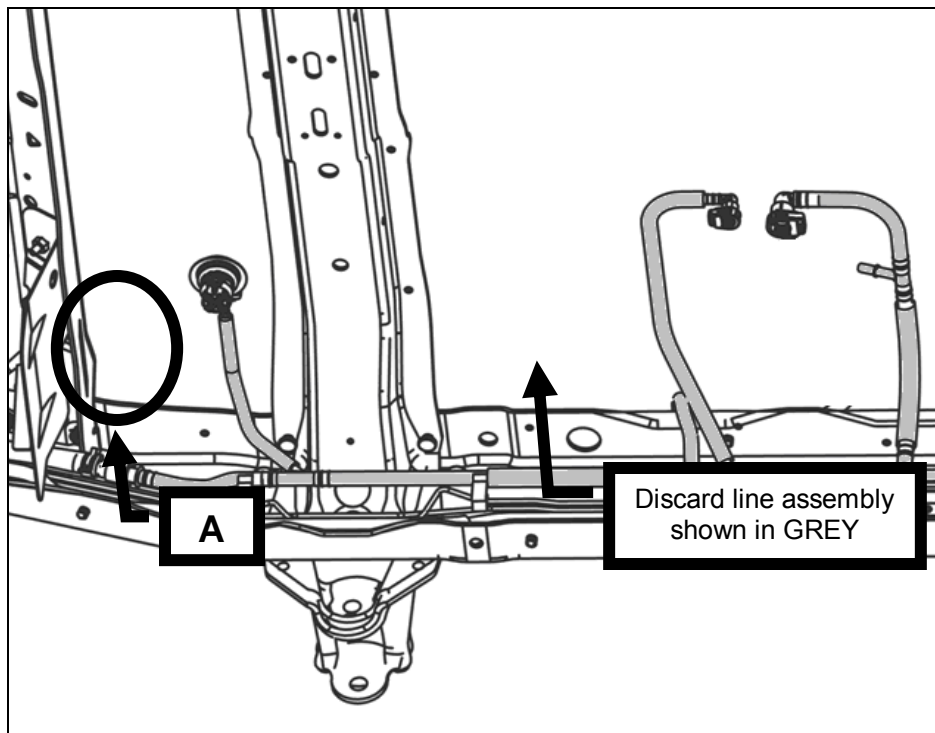

ROUSH CleanTech E-150/250/350 Liquid Propane Autogas 2010 Kit Installation Instructions

2. Preassemble the FTPT Closure Quick Connect Fitting (20006400) and FTPT Vacuum Cap (MR0150). These components can be found in Hardware Kit F, Fuel Rail Pressure Control System (P10C2-HKF-AA). Install the Fitting (Item #1) and Vacuum Cap (Item #2) into the open connector found in location "A".

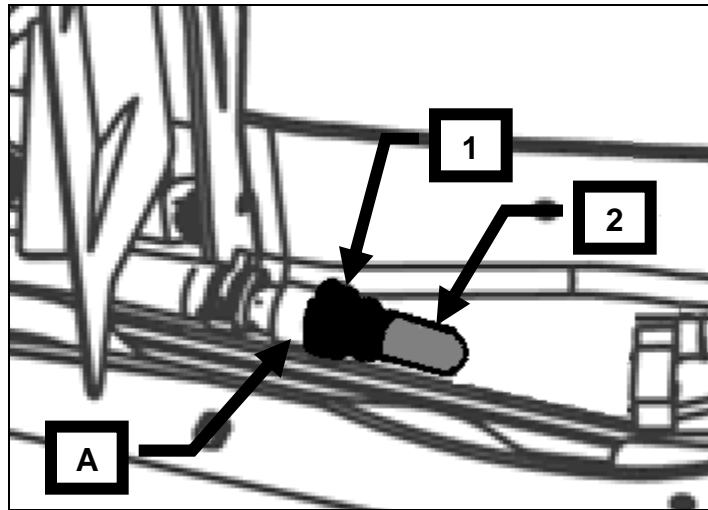

Removing the Original Filler Pipe

Refer to the Ford Technical Services, Service Information, Section 310-01, Fuel Tank and Lines, for complete instructions for removing the original filler pipe.

Removing the Original Fuel Supply Line

Refer to Ford Technical Services, Service Information, Section 310-01, Fuel Tank and Lines, Fuel Lines, for complete instructions for removing the fuel supply line except as follows:

Be careful **NOT** to remove, damage or discard any fuel line retention brackets attached to either the frame or transmission. These clips/brackets will be used to retain the new propane fuel lines.

ROUSH CleanTech E-150/250/350 Liquid Propane Autogas 2010 Kit Installation Instructions

Preparing the Engine Compartment

Refer to the Ford Technical Services, Service Information, Section 303-04A, Fuel Charging and Controls, Removal and Installation, for complete instructions for removing the fuel rails and injectors.

Some parts will be reused. The following procedures indicate which items may be salvaged or discarded and which are to be set aside for reuse.

- ▲ **Danger:** — The fuel supply lines remain pressurized after engine shutdown. Keep away from heat, sparks, flames, static electricity or other sources of ignition. Do **NOT** enter storage areas or confined spaces unless they are adequately ventilated. Failure to heed this danger may result in severe personal injury or death.
- ▲ **Danger:** — Read and follow all applicable alert messages in the Ford manual. Failure to heed this danger may result in severe personal injury.
- ▲ **Danger:** If not already done, disconnect the battery terminals from the battery.

1. Remove the engine cover (doghouse) located inside the vehicle to gain access to the top and rear of the engine.
2. Remove the air cleaner inlet assembly, disconnect the MAF sensor connector and remove the air cleaner cover. The upper radiator shroud will need to be removed for tool access. These components and fasteners will be reused.

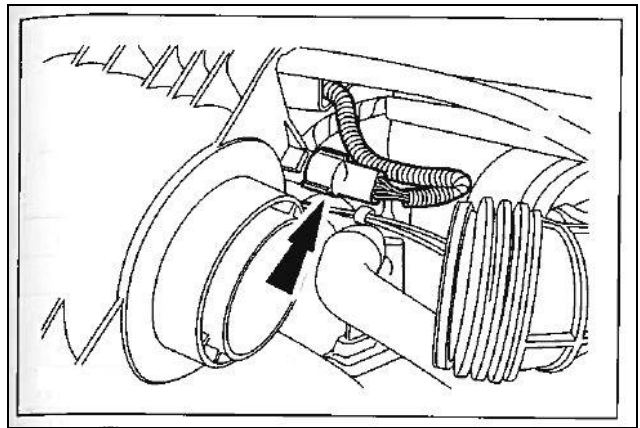
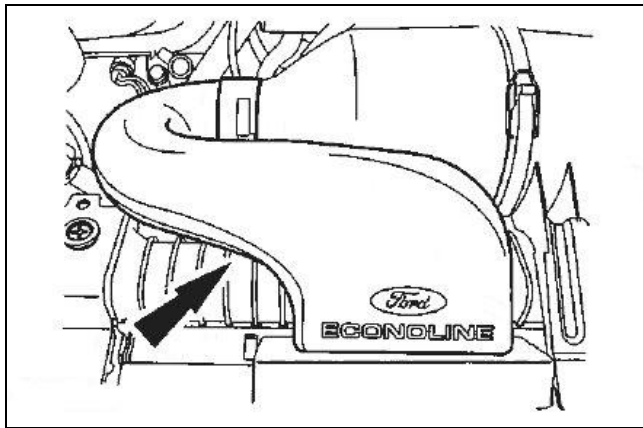

3. Disconnect and remove both PCV lines/tubes for additional working clearance. These tubes will be reused.

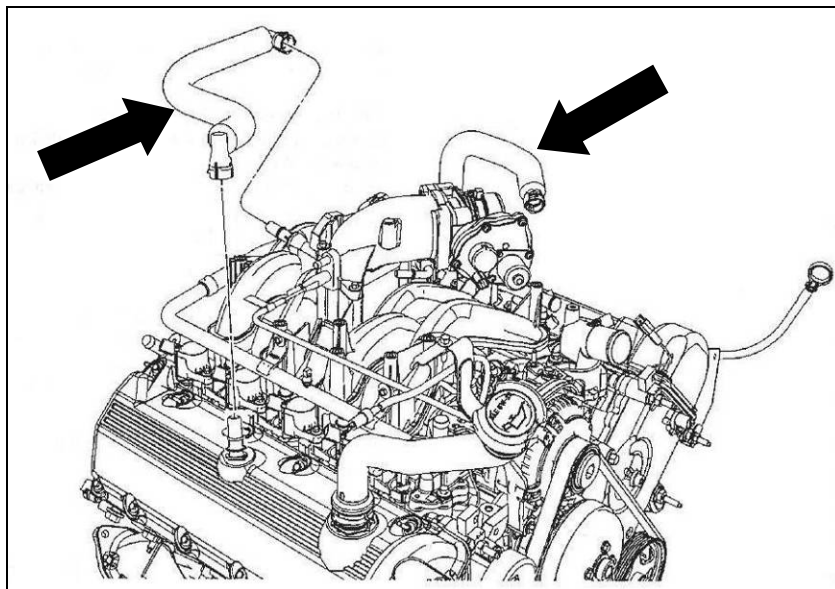

ROUSH CleanTech E-150/250/350 Liquid Propane Autogas 2010 Kit Installation Instructions

4. Remove the bolt which retains the transmission dipstick mounting bracket to the intake manifold. Do not remove the dipstick tube from the transmission. The following modification can be done in vehicle. Place a suitable cloth below the dipstick mounting bracket to cover engine components and catch metal cuttings and debris.

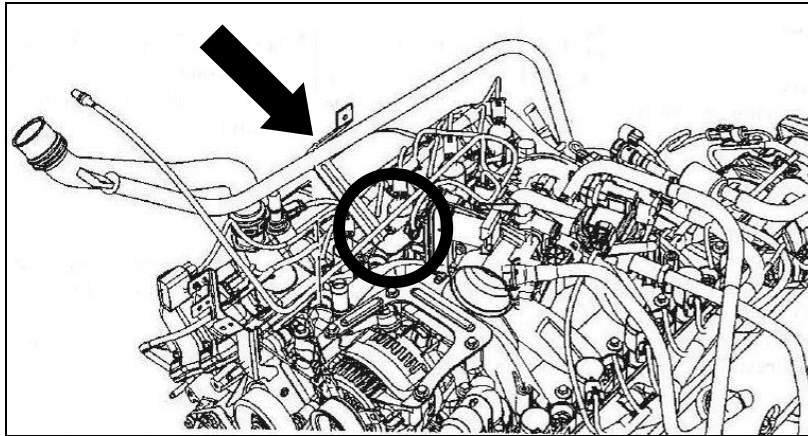

5. Modify the factory dipstick tube mounting bracket as shown below. The cut line will be 12mm (1/2") below the edge of the existing hole in the bracket. Deburr and apply a rust preventative coating to the newly cut edge of the bracket. Roush suggests Motorcraft Premium Undercoating (PM-25-A).

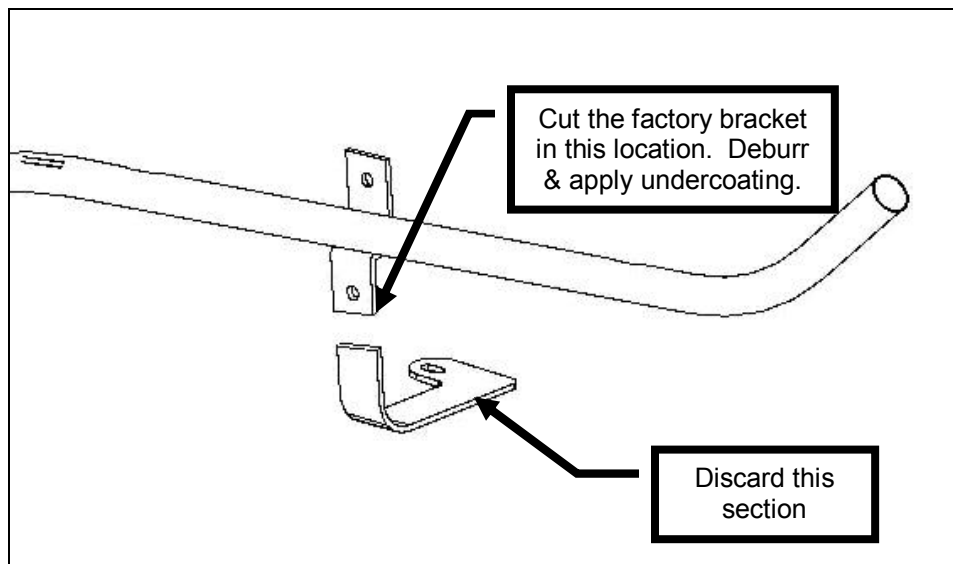

ROUSH CleanTech E-150/250/350 Liquid Propane Autogas 2010 Kit Installation Instructions

6. Disconnect the VMV tube from the VMV valve located at the rear of the engine. DO NOT remove the VMV valve from the intake.

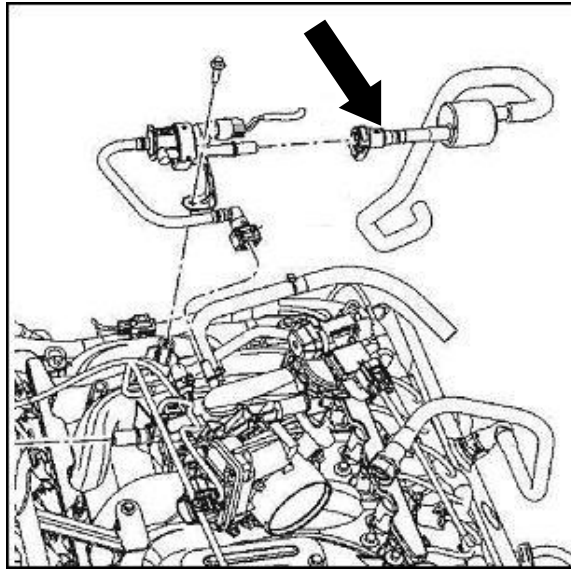

7. Disconnect all eight fuel injectors from the engine wiring harness.

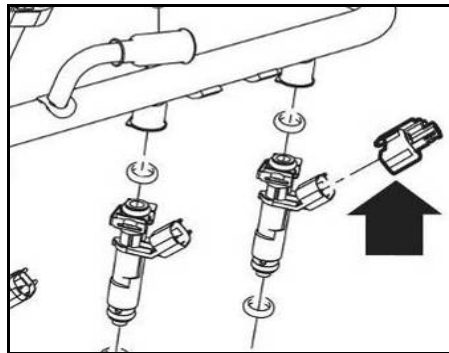

8. Using a Ford-approved fuel line removal tool, disconnect the fuel supply line from the fuel rail. Remove and set aside the fuel rail and injectors. The rail and injectors will not be reused. Retain the fuel rail mounting fasteners as they will be re-purposed in a later step.

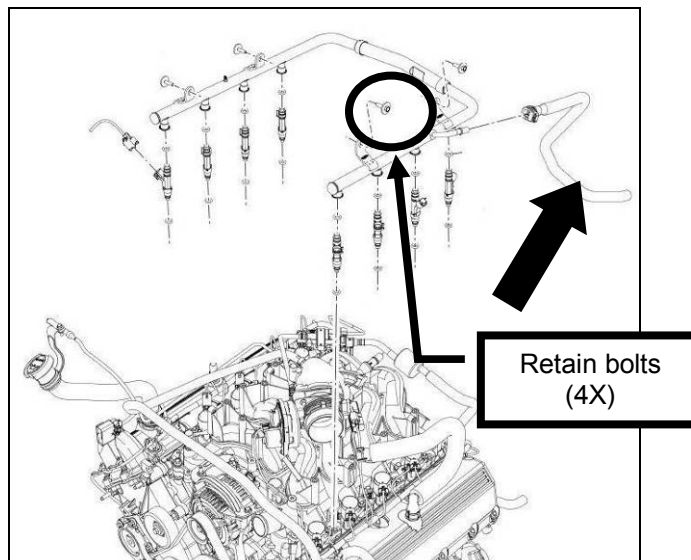

ROUSH CleanTech E-150/250/350 Liquid Propane Autogas 2010 Kit Installation Instructions

Installing the New Fuel Rail Assemblies

- ▲ **Caution:** — Hand tighten all fuel line connectors and fasteners before applying a wrench to avoid cross threading. Failure to heed this caution may result in property damage.
1. Using engine oil (Motorcraft SAE 5W-20 or equivalent), lubricate the lower O-rings on the injector nozzles before seating the rail assemblies into the intake manifold injector pockets.
 2. Position the Left Hand Fuel Rail Assembly (P10C2-9F899-AA) onto the driver side of the intake manifold and fully seat the nozzles. Using two (2) M6 x 1 x 23 bolts (W704641-S437) found in Hardware Kit A (P10C2-HKA-AA), secure the LH fuel rail to the intake manifold. Carefully install bolts by hand to avoid cross-threading; then, torque bolts to 8 – 12 Nm.
- ▲ **Caution:** — Ensure the nozzles are correctly aligned before seating. Failure to heed this caution could result in serious property damage.

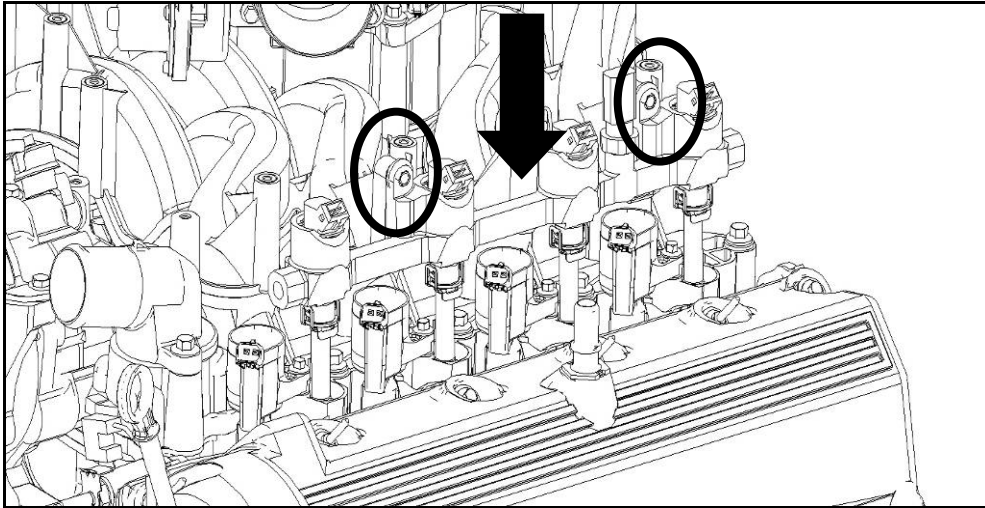

3. Position the Right Hand Fuel Rail Assembly (P10C2-9F899-BA) onto the passenger side of the intake manifold and fully seat the nozzles. Using two (2) M6 x 1 x 23 bolts (W704641-S437) found in Hardware Kit A (P10C2-HKA-AA), secure the RH fuel rail to the intake manifold. Carefully install bolts by hand to avoid cross-threading; then, torque bolts to 8 – 12 Nm.
- ▲ **Caution:** — Ensure the nozzles are correctly aligned before seating. Failure to heed this caution could result in serious property damage.

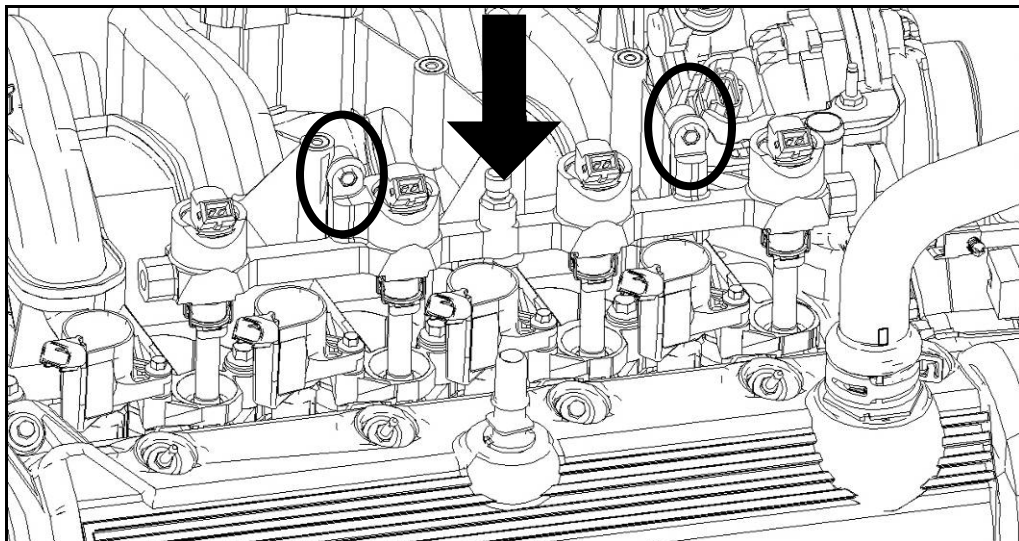

ROUSH CleanTech E-150/250/350 Liquid Propane Autogas 2010 Kit Installation Instructions

- Orient and install the Crossover Fuel Line (P10C2-9F893-AA) onto the forward ends of the fuel rails as shown below. Torque connections to 18 – 22 Nm.

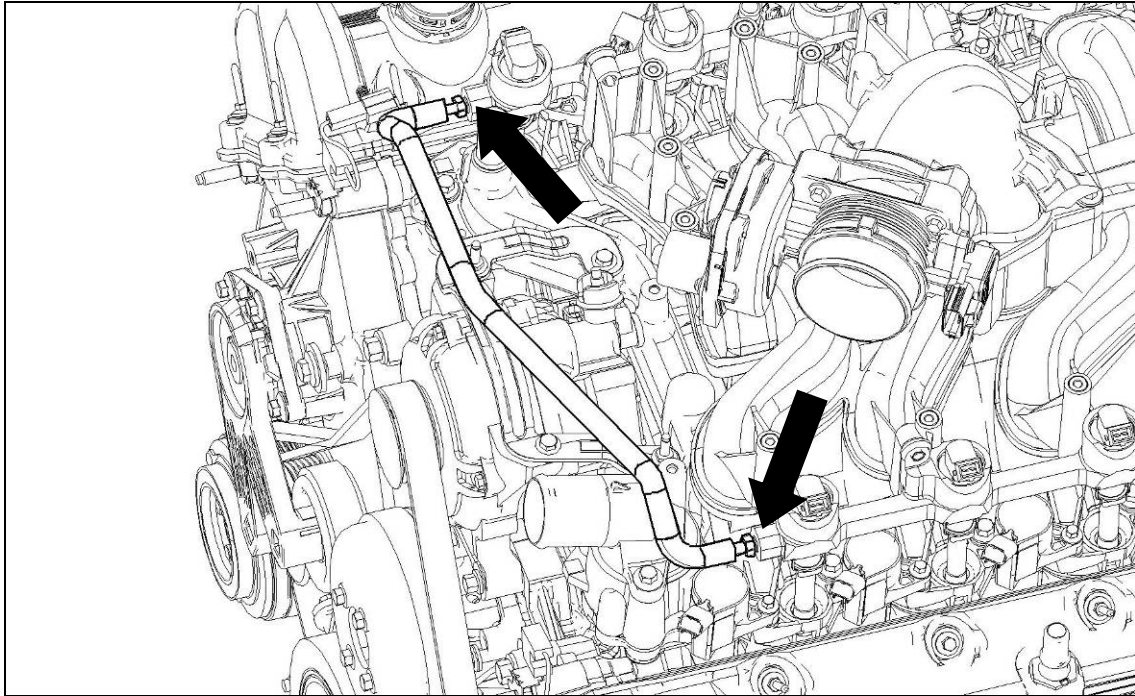

- Connect one (1) Fuel Injector Jumper (P07L3-9C978-AB) to each original harness connector (8 places). These can be found in Hardware Kit G (P10C2-HKG-AA). Connect the opposite end of each jumper to its respective fuel injector.

⚠ Caution: — Ensure that each jumper attaches to its correct mating connector to avoid cross wiring. Failure to heed this caution will result in engine malfunction and possible property damage.

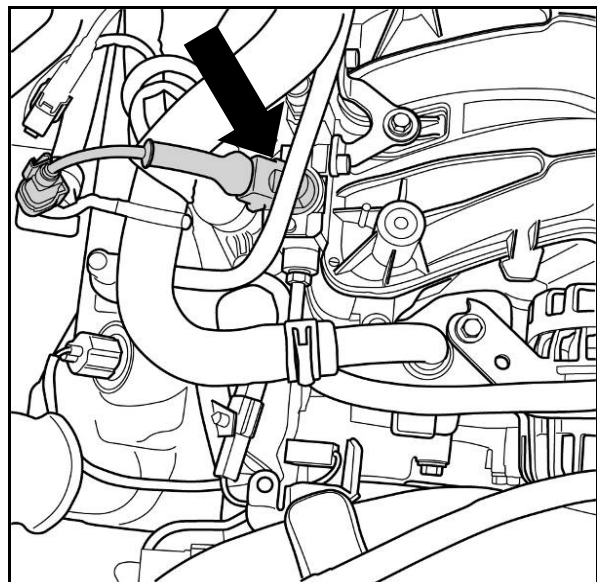
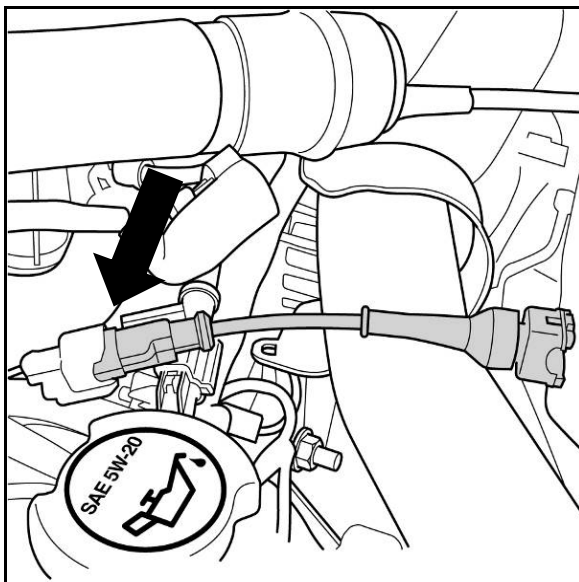

ROUSH CleanTech E-150/250/350 Liquid Propane Autogas 2010 Kit Installation Instructions

6. Install the Transmission Dipstick Tube Mounting Bracket (P10C2-7H379-AA) found in Hardware Kit A (P10C2-HKA-AA) to both the intake manifold and previously modified transmission dipstick mounting bracket using three (3) take off M6 fuel rail mounting fasteners in the locations shown. Torque to 8 – 12 Nm.

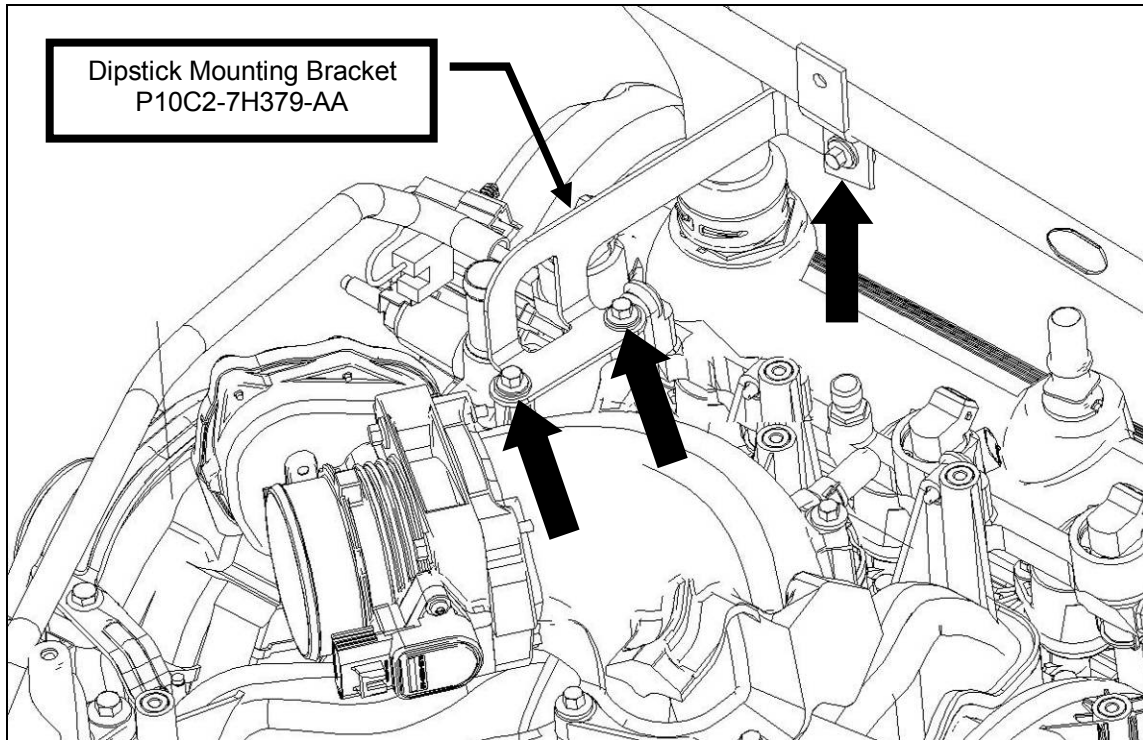

7. Re-install the PCV Hoses that were previously removed for added accessibility.

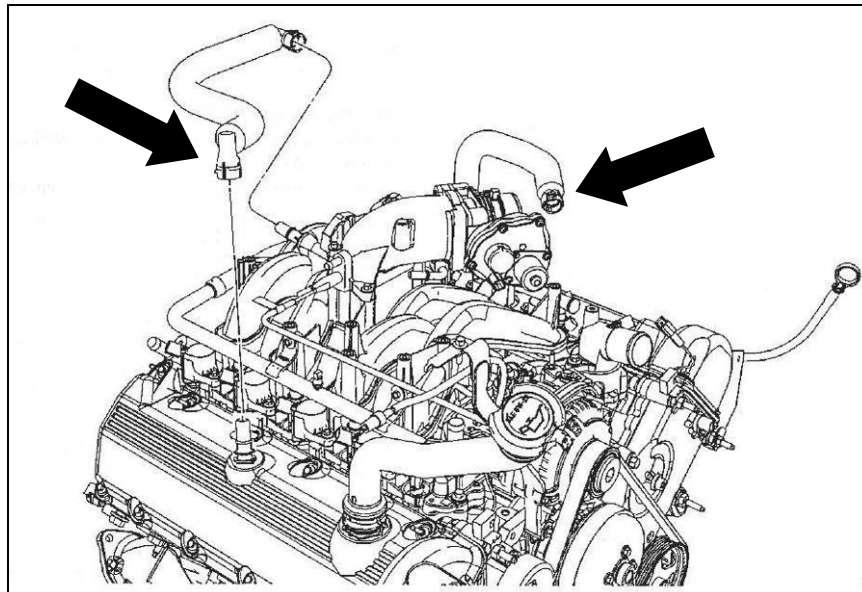

ROUSH CleanTech E-150/250/350 Liquid Propane Autogas 2010 Kit Installation Instructions

Installing the Fuel Rail Pressure Control Module (FRPCM)

⚠ Caution: — Hand tighten all fuel line connectors and fasteners before applying a wrench to avoid cross threading. Failure to heed this caution may result in property damage.

1. Install the FRPCM Mounting Bracket (P10C2-9E360-AA) onto the FRPCM using the two (2) M6 x 1.0 x 18 mm bolts (N605891-S437) as shown below. Torque to 8 – 12Nm. These parts can be found in Hardware Kit F (P10C2-HKF-AA).

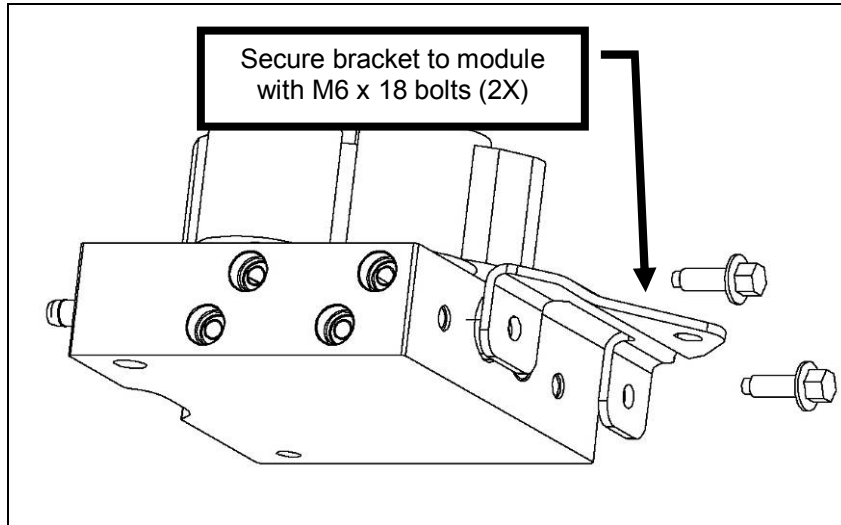

2. Remove and retain the left-rear throttle body spacer-to-intake manifold bolt. Position the FRPCM onto the two vertical bosses located on the left rear corner of the intake manifold. Loosely install two (2) M6 x 1.0 x 62 fasteners (W709552-S437), found in Hardware Kit F (P10C2-HKF-AA) to secure the FRPCM to the intake manifold. The mounting bracket should now be aligned with the rear left throttle spacer mounting hole. Reinstall the throttle spacer bolt. Torque all bolts to 8- 12 Nm.

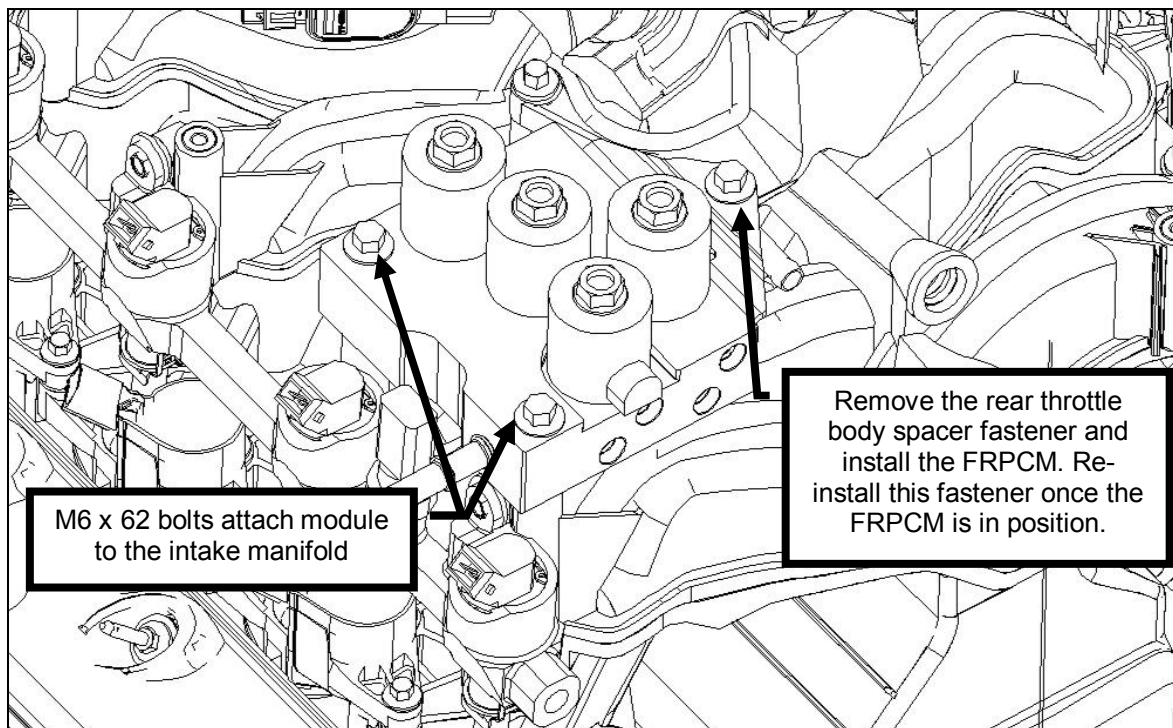

ROUSH CleanTech E-150/250/350 Liquid Propane Autogas 2010 Kit Installation Instructions

Installing the New Wiring Harness

Note: A graphic representation of the wiring harness is shown below. We recommend reviewing this illustration and becoming familiar with each connector along with its corresponding location on the vehicle prior to installation.

Note: Disconnect the "CAN Network" section of the wiring harness from the main harness.

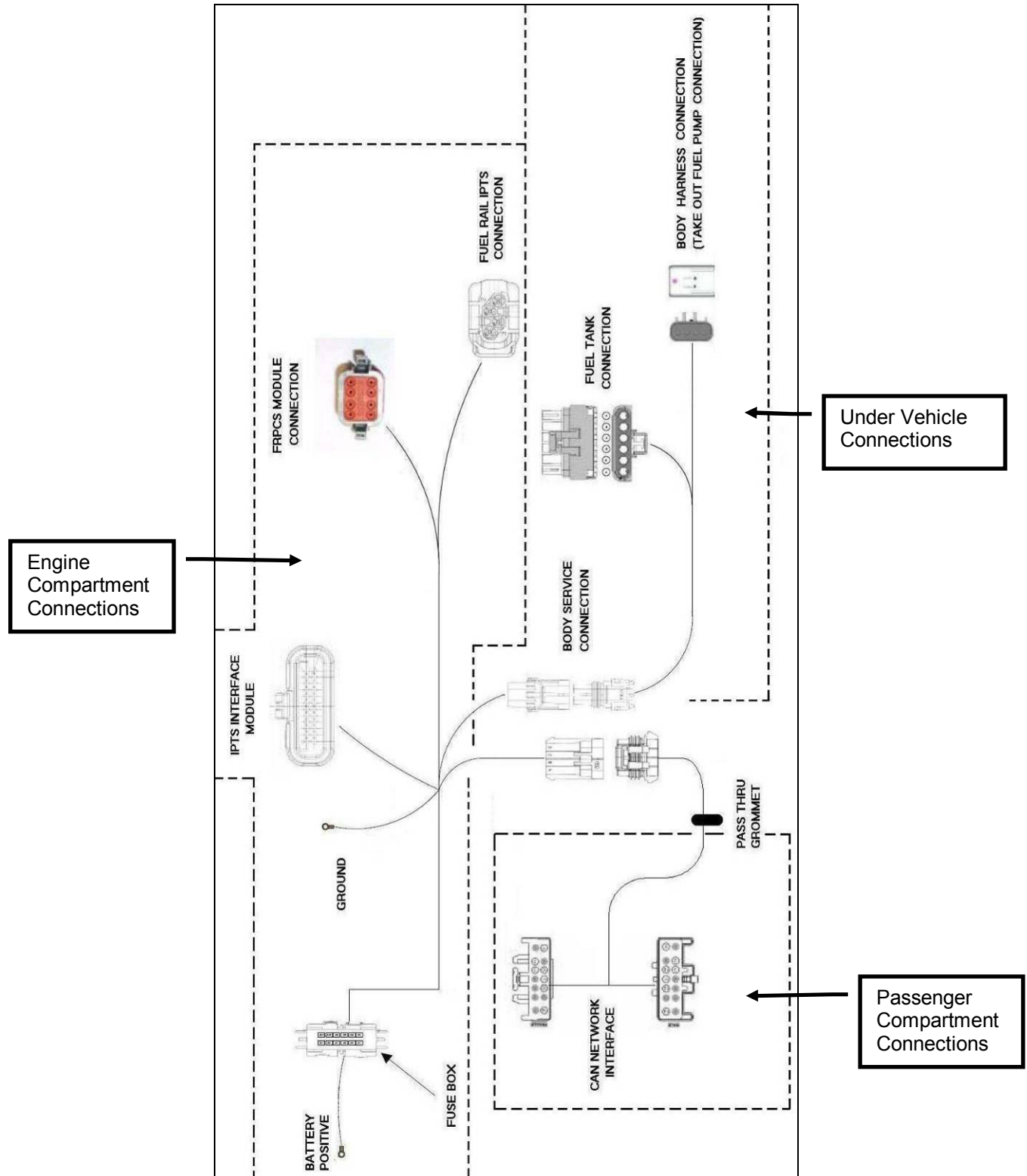

ROUSH CleanTech E-150/250/350 Liquid Propane Autogas 2010 Kit Installation Instructions

1. Remove and retain the three degas bottle mounting fasteners and lay the degas bottle on its side atop the brake booster as shown.

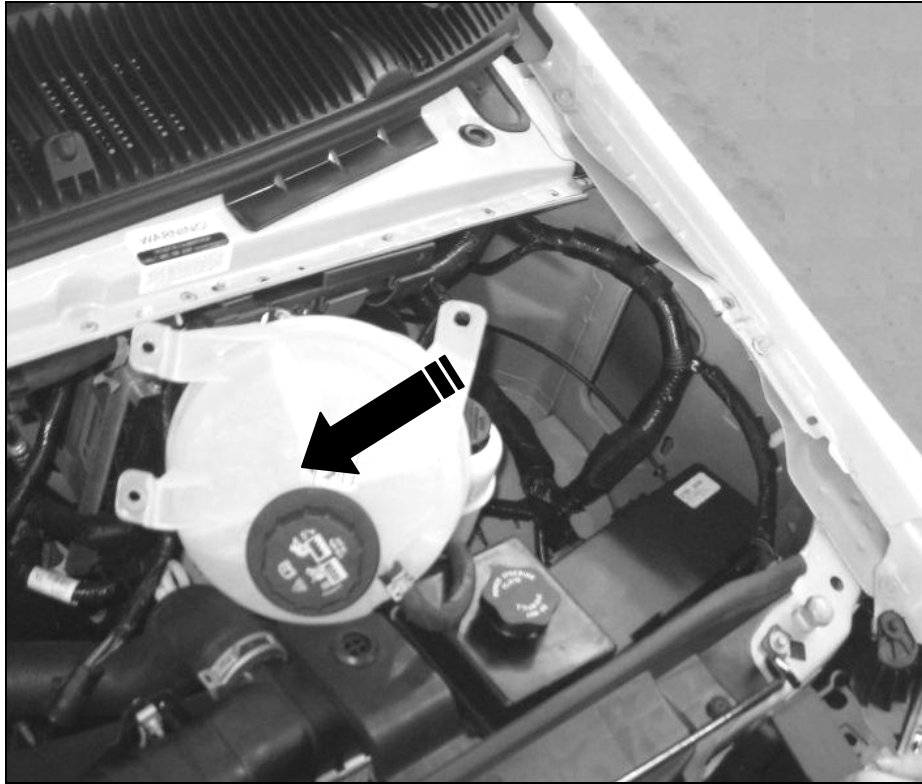

2. Position the IPTS Interface Module (P10C2-12A650-AA) onto the inner fender in the position shown. Using three (3) #12-14 x 1.5" Self Tapping Screws (91324A582) found in Hardware Kit G (P10C2-HKG-AA), secure the module to the inner fender. NOTE: It may be necessary to remove the wiring harness push pins/retainers from the inner fender to gain working access to this area. Once the module is installed, reinstall the push pins to secure the wiring to the inner fender.

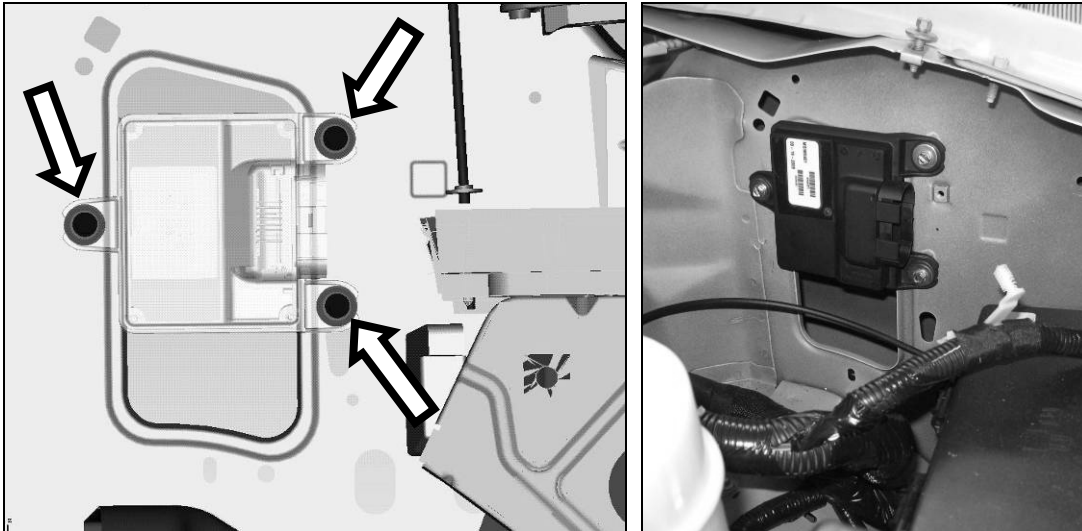

ROUSH CleanTech E-150/250/350 Liquid Propane Autogas 2010 Kit Installation Instructions

3. Drill a 29 mm (1 1/8") hole in the dash panel to the right of the master cylinder and main wiring pass through in the location shown (indent in sheet metal).

⚠ Caution: Use care when drilling to avoid damaging the wiring harness in the cab interior behind the panel. Use a 29 mm hole saw with a pilot bit extending NO MORE than 1/2-inch beyond the saw teeth and push the drill no deeper than what is necessary to cut through the metal panel.

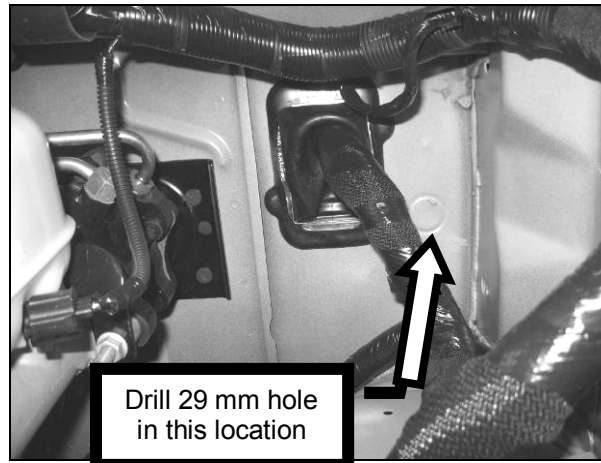

4. From the passenger side of the instrument panel, grasp the instrument cluster finish panel at the lower right corner and the top and carefully pull back to release the retention tabs. Carefully continue to pull the right side of the panel back just enough (approximately three (3) inches) to gain access to connectors for completing the ROUSH CleanTech harness connections illustrated in steps 5 and 6.

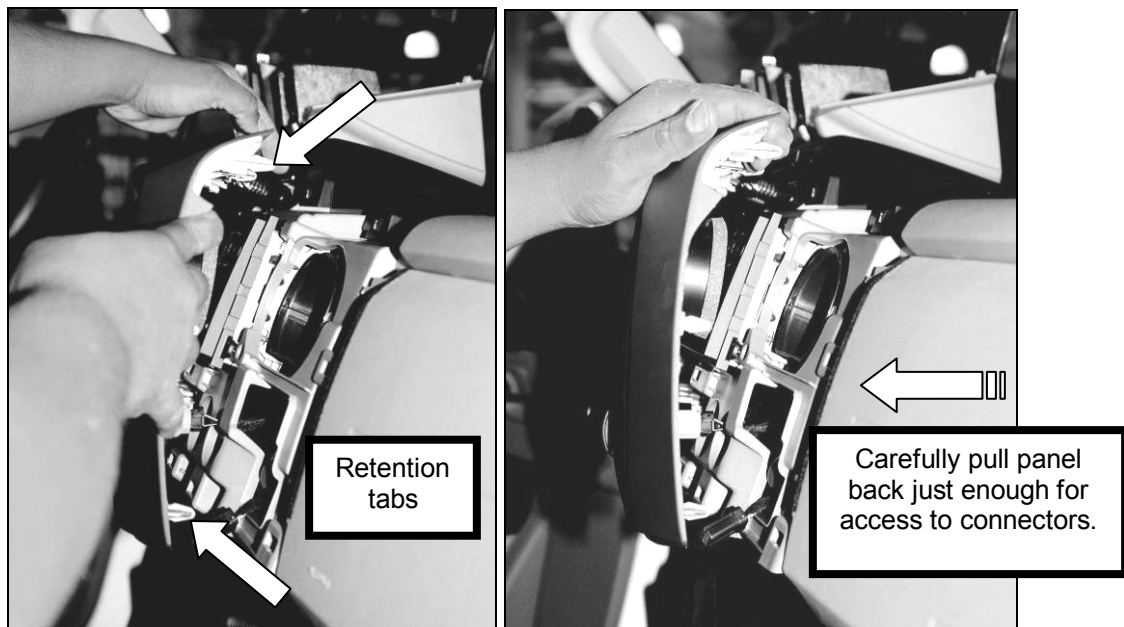

Note: In steps 5 and 6, the change cubby/close out panel is removed for clarity in illustrating the electrical connections to be made. It is not necessary to remove the change cubby/close out panel in making the connections. (Model with optional electronic brake controller is shown.)

5. If vehicle is equipped with an electronic trailer brake controller, disconnect the harness from the brake controller. On models not equipped with the electronic brake controller the wiring harness connector "A" (see next page) will be stowed in this area from the factory.

ROUSH CleanTech E-150/250/350 Liquid Propane Autogas 2010 Kit Installation Instructions

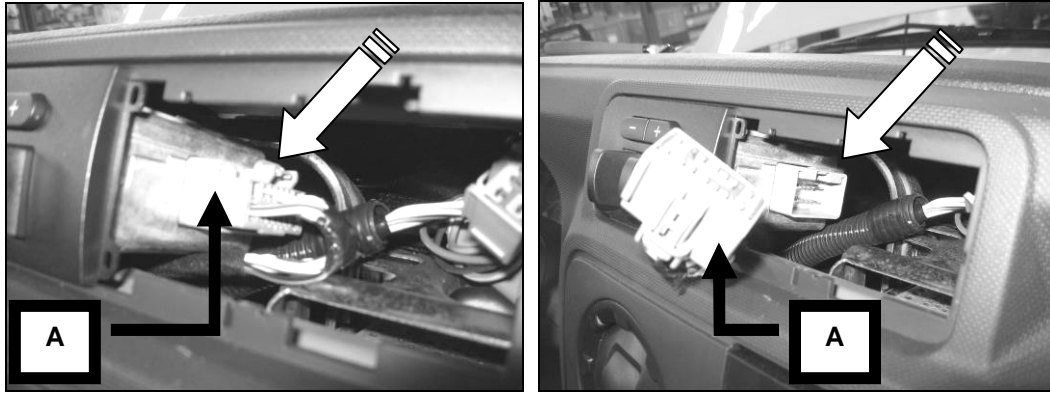

6. Insert the opposite end of the harness from connectors B and C through this opening and pull the wiring through until the two multi-pin connectors (B and C) are inside the opening. Connect the "B" end of the new "CAN Network" section of the wiring harness to the brake controller & the opposite end "C" to the vehicle harness "A" that is either stowed in this area or was disconnected from the trailer brake controller.

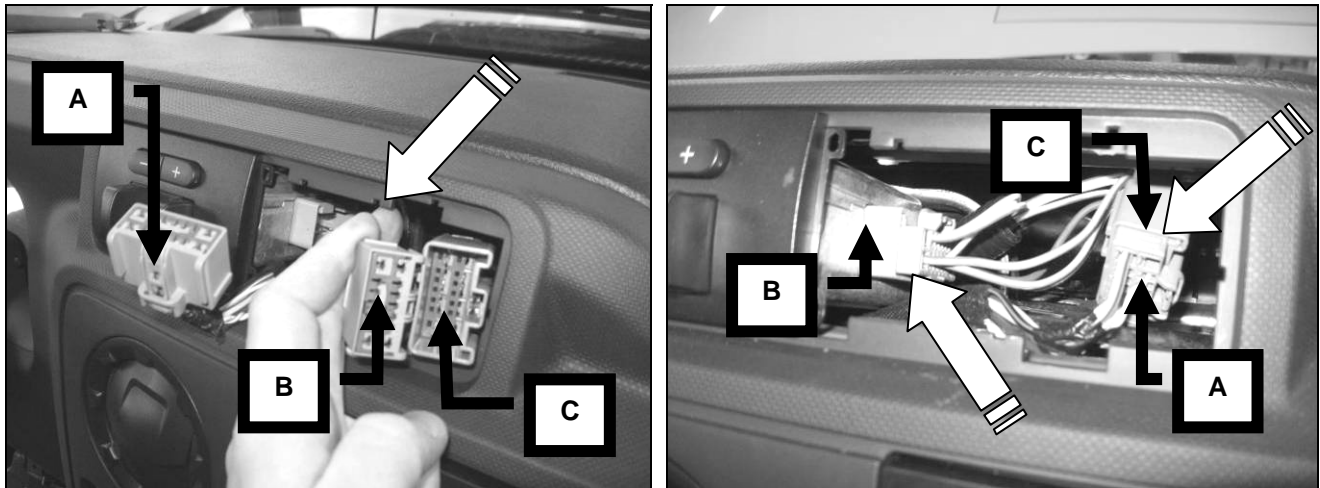

7. Route the end of the harness with the single connector down through the dash, behind the close out panel located below the steering wheel. The close out panel below the steering wheel will have to be removed to access this area. Secure the harness to the factory wiring with zip ties and route it over to the hole that was drilled through the dash panel beside the fuse box.

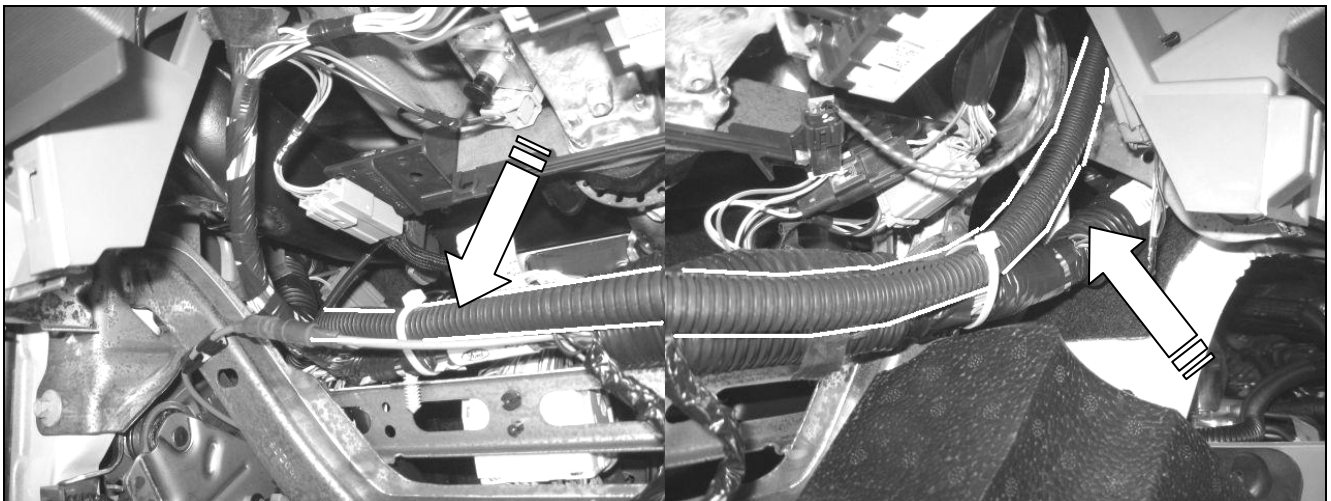

ROUSH CleanTech E-150/250/350 Liquid Propane Autogas 2010 Kit Installation Instructions

- From inside the passenger compartment, beside the fuse panel to the left of the gas pedal, carefully pass the end of the harness through the dash panel until the grommet is properly seated in the newly drilled hole.

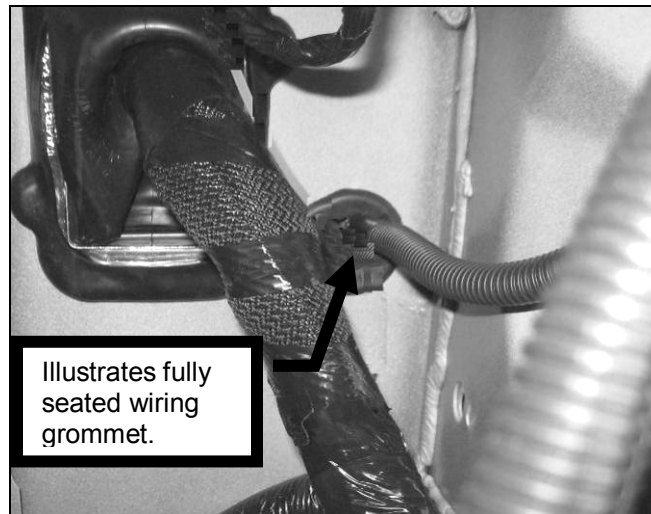

- Position the "Fuse Box" portion of the Wiring Harness Assembly (P10C2-3075-AA) onto the back edge of the Ford Fuse box bracket as shown. Secure the fuse box to the Ford fuse box bracket using the two (2) #12-14 x 0.75" Self Tapping Screws (91324A580) found in Hardware Kit G (P10C2-HKG-AA). Once the fuse box is firmly secured to the bracket, make the connection between the wiring harness and the newly installed IPTS Module on the inner fender. Reconnect the "CAN Network" section of the harness which passes through the dash panel to the main harness.

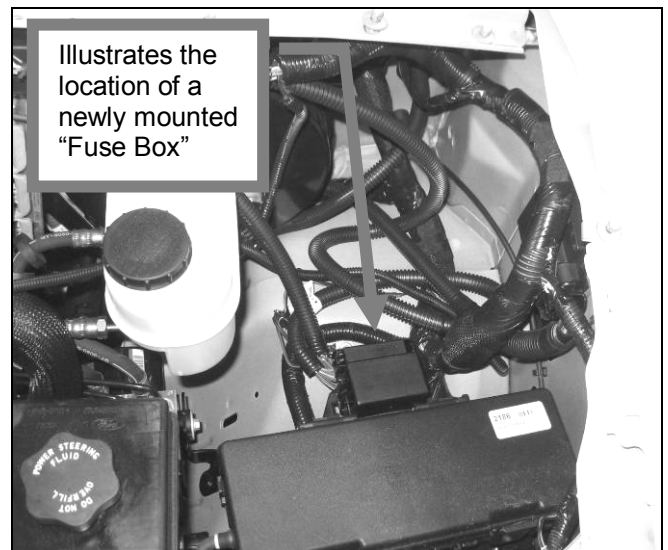
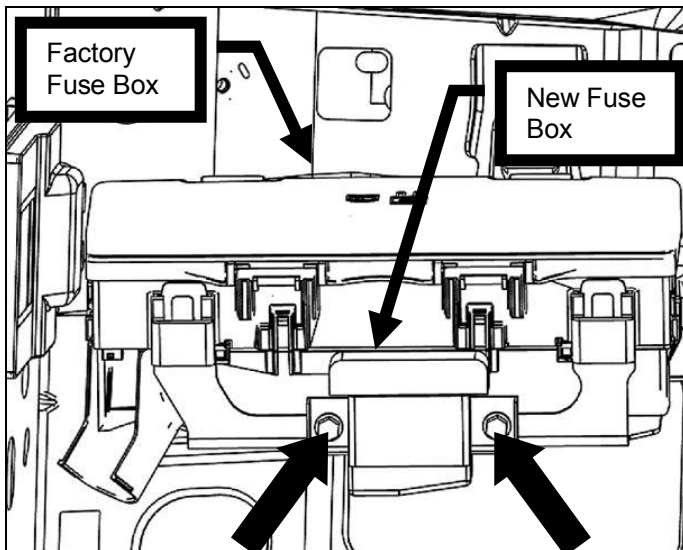

ROUSH CleanTech E-150/250/350 Liquid Propane Autogas 2010 Kit Installation Instructions

- Secure the wiring harness **system ground eyelet "A"** to the existing ground location found rear of fuse box on the inner fender as shown. Secure the second wiring harness **shield ground eyelet "B"** in the other ground location.

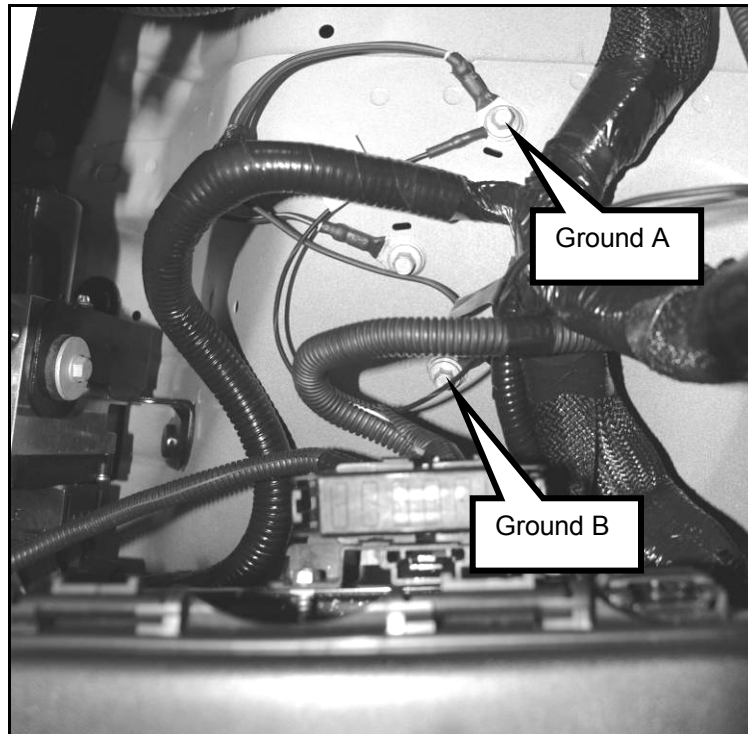

- Open the factory Ford fuse box and connect the new wiring harness **battery positive eyelet** to the positive post.
- Route the remainder of the harness toward the engine along the cowl/dash panel below the brake booster. Route the break out with the 6 pin service connection behind the engine and back toward the left (driver side) frame rail, following the Ford chassis harness.

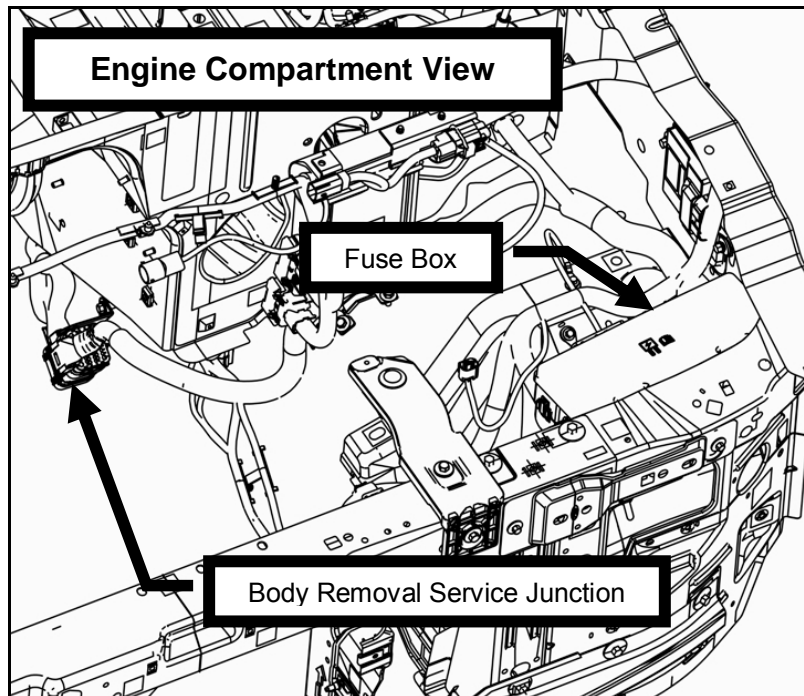

ROUSH CleanTech E-150/250/350 Liquid Propane Autogas 2010 Kit Installation Instructions

Note: Ensure that the Roush main harness is routed away from the exhaust pipes, manifolds, catalytic converters and exhaust heat shields.

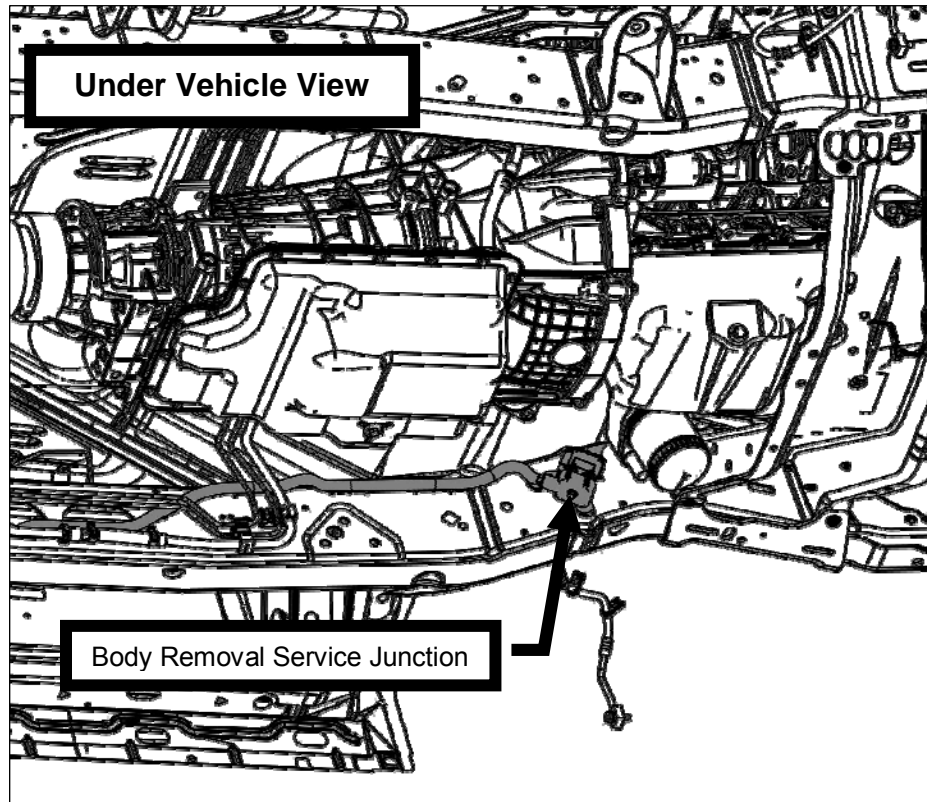

13. Re-install the degas bottle using the take out fasteners. Torque fasteners to 8 – 12 Nm.
14. Route the IPTS and FRPCM connectors beside the factory engine wiring harness along left side of the engine. Plug in both the IPTS and FRPCM connectors.

Note: It is recommended to route the entire harness under the brake booster and steering column, and make all connections prior to retaining the harness with zip ties. Retaining the wire harness with zip ties is the final step of the wiring harness install.

ROUSH CleanTech E-150/250/350 Liquid Propane Autogas 2010 Kit Installation Instructions

15. Continue to route the Roush harness under the brake booster and steering column, and along the Ford harness beneath the vehicle. Use wire ties to secure the harnesses to each other. Plug the 4 pin connector into the Fuel Pump/Sender Connector of the Ford vehicle harness (This connection was broken when the original gasoline fuel tank was removed from the vehicle).

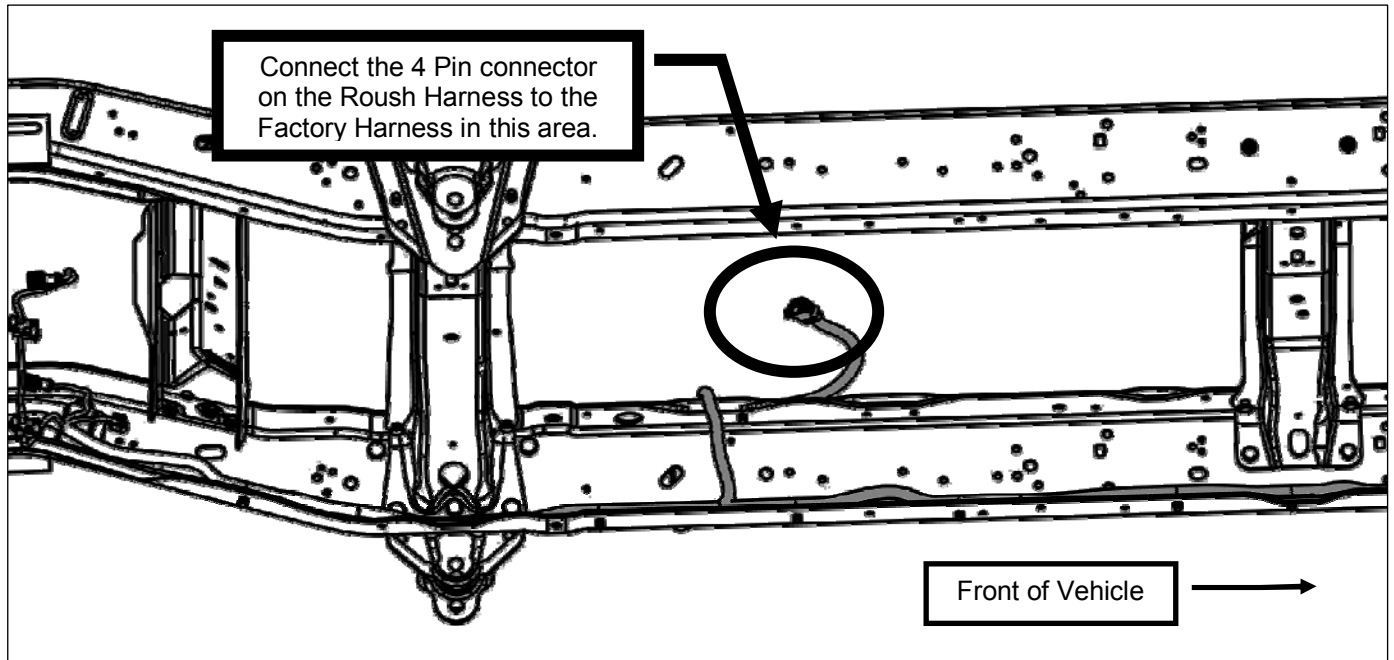

16. Use zip ties to secure the harnesses and the 6 pin connector to the main body harness. Once the tank goes into position, this connection can be made.

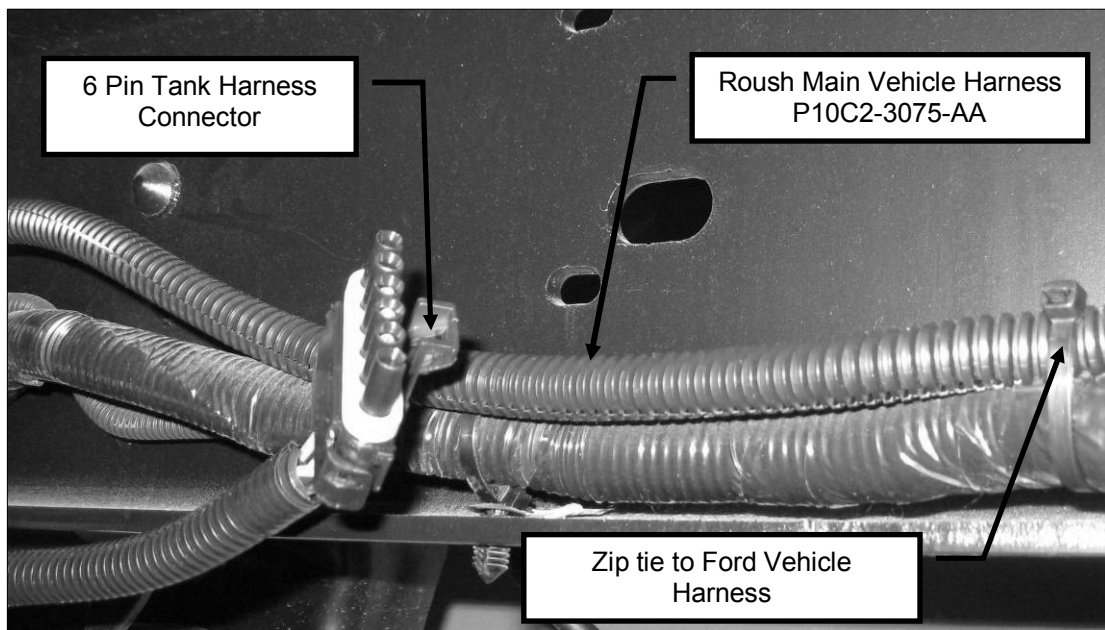

Note: It is recommended to route the entire harness and make all connections prior to retaining the harness with zip ties. Retaining the wire harness with zip ties is the final step of the wiring harness install.

ROUSH CleanTech E-150/250/350 Liquid Propane Autogas 2010 Kit Installation Instructions

Installing the New Fuel Fill System

⚠ Caution: — Hand tighten all fuel line connectors and fasteners before applying a wrench to avoid cross threading. Failure to heed this caution may result in property damage.

1. Remove the nut from the Fuel Fill Valve (PV1855BRCN) and assemble the valve to the Fuel Filler Neck Mounting Bracket (P10C2-9B213-AA) as shown. Support the fill valve and bracket assembly and tighten the nut securely. These parts can be found in Hardware Kit D (P10C2-HKD-AA).

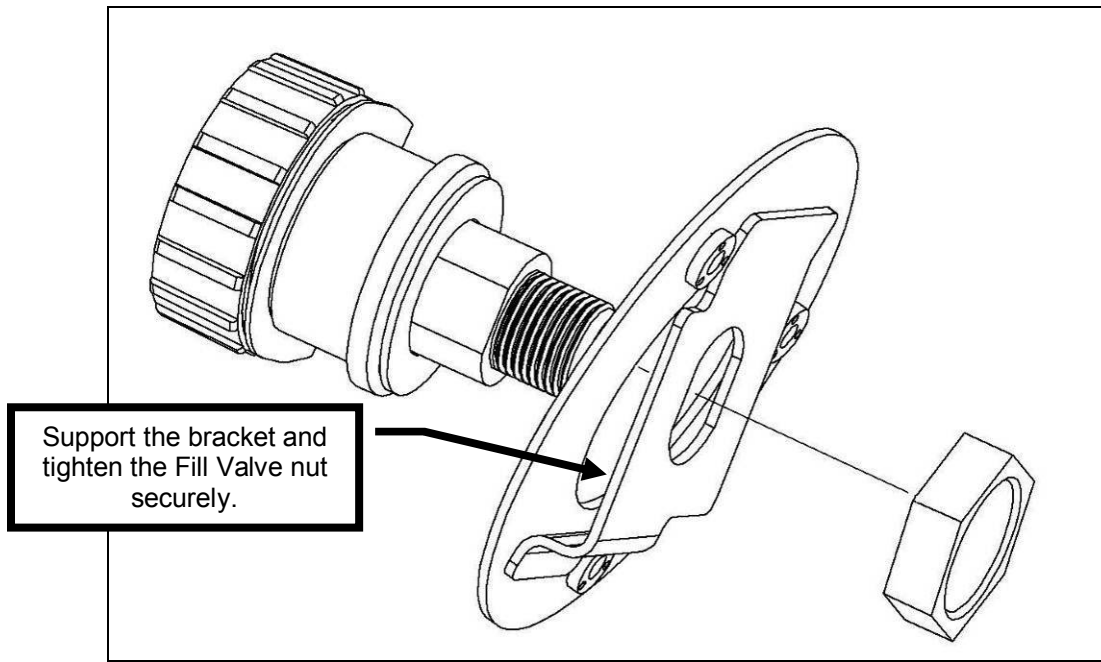

2. Install the Fuel Fill Valve and Fuel Filler Neck Mounting Bracket behind the factory fill door using three (3) M5 x 0.8 x 16mm bolts (W706841-S437). These bolts can be found in Hardware Kit D (P10C2-HKD-AA). Torque the bolts to 5 - 7 Nm.

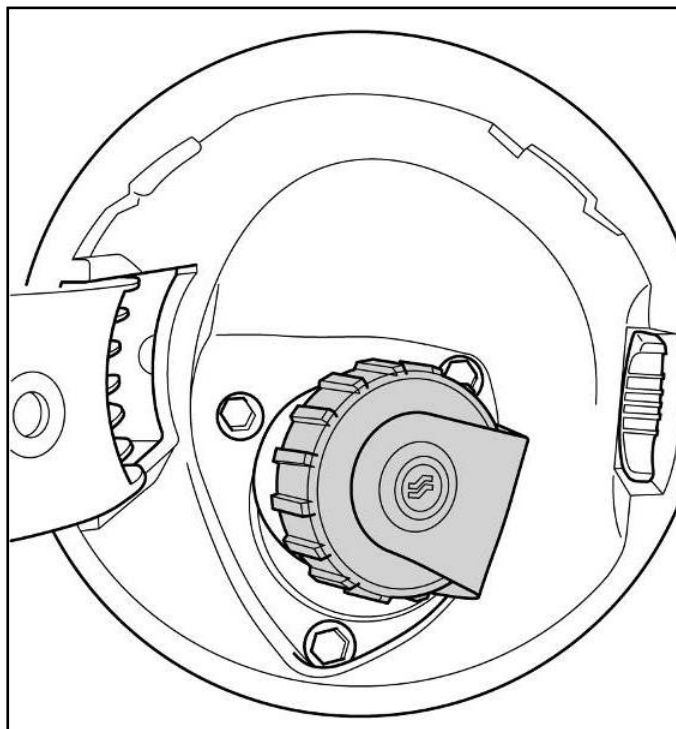

ROUSH CleanTech E-150/250/350 Liquid Propane Autogas 2010 Kit Installation Instructions

3. Assemble the Fuel Fill Filter (P07L3-9155-AA) to the Fuel Fill Filter Bracket and Clamp Assembly (P11C2-9180ASY-AA). Torque clamp to 4 – 5 Nm.

Note: The arrow on the filter indicates the direction of flow; ensure the filter is assembled to the bracket in the correct orientation as shown. The hex-head of the clamp worm gear must face downward for access when the filter bracket assembly is installed on the vehicle.

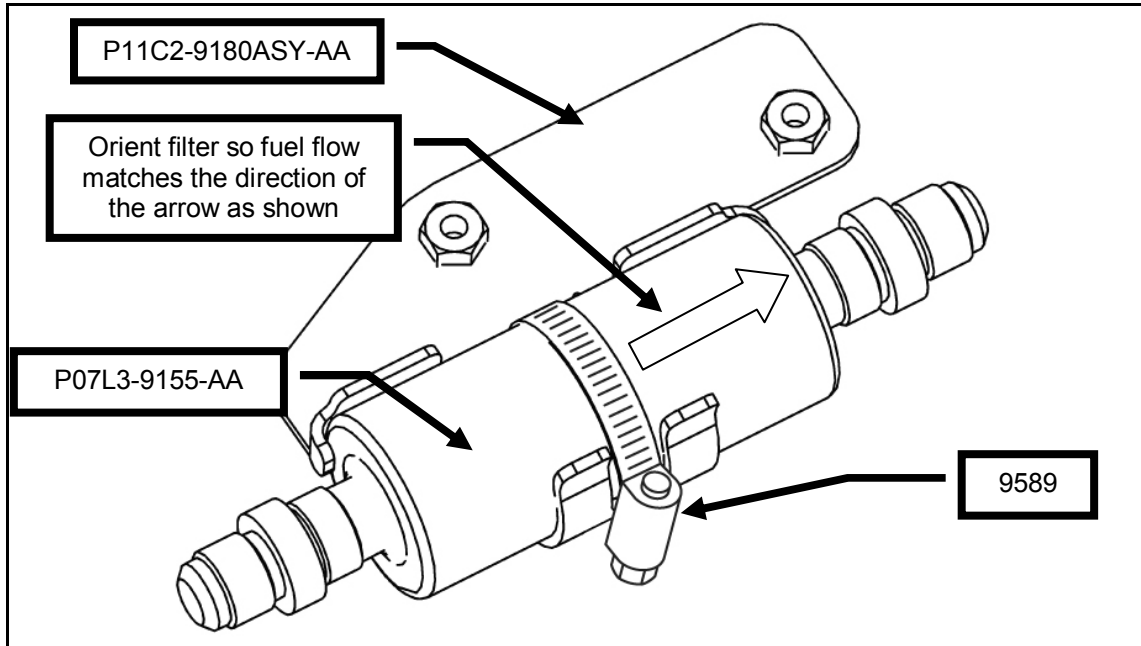

4. Install the Filter and Bracket Assembly to the frame using two (2) M6 x 1.0 x 22 bolts (R18020057-00-AA). These can be found in Hardware Kit D (P10C2-HKD-AA). Torque to 20 – 30 Nm.

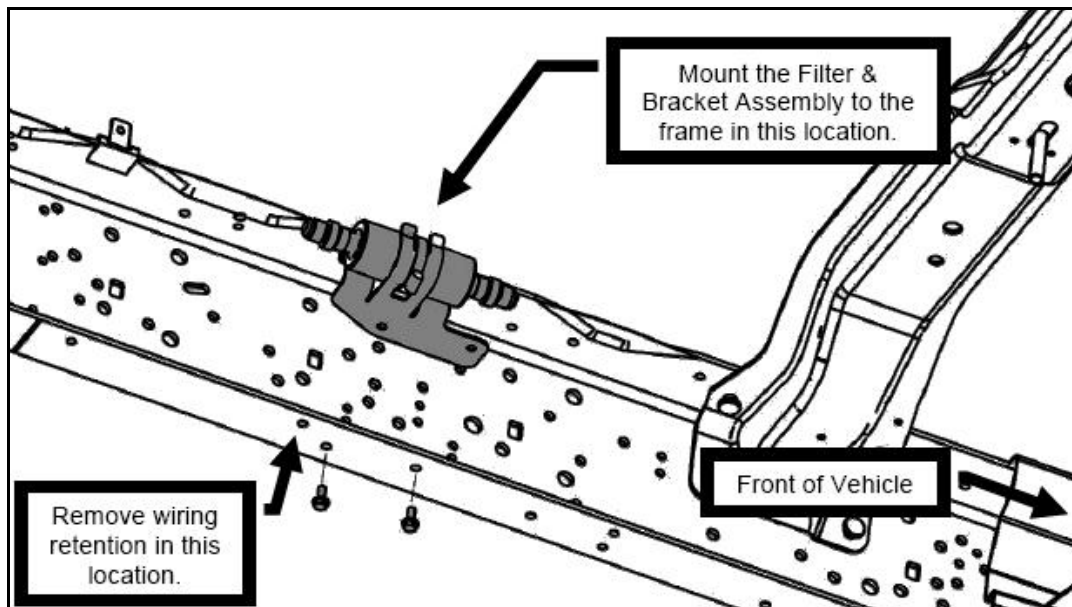

ROUSH CleanTech E-150/250/350 Liquid Propane Autogas 2010 Kit Installation Instructions

5. Install the Fuel Fill Hose (P10C2-9034-BA) to the Fuel Fill Valve.

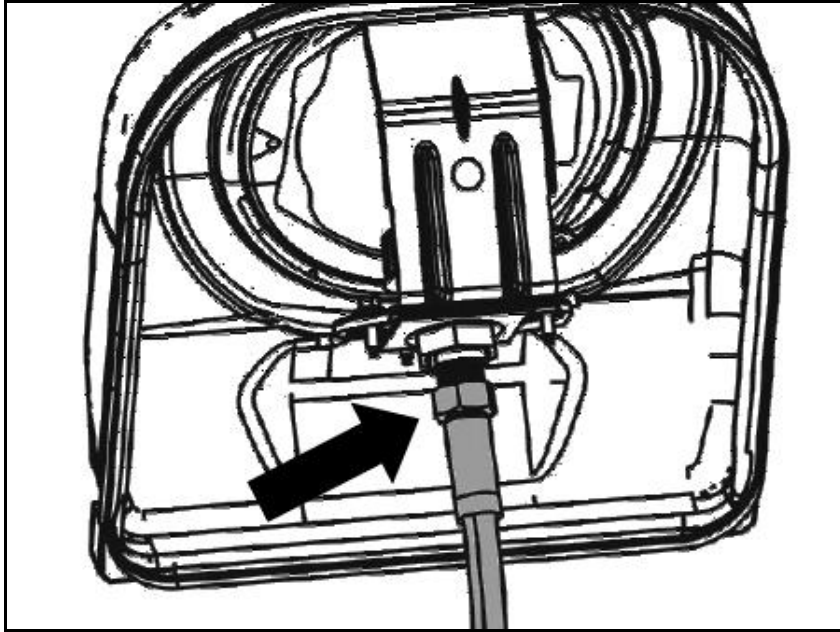

6. Route the Fuel Fill Hose from the Fuel Fill Valve over the frame, to the frame-mounted Fuel Filter as shown. Torque both line fittings to 41 – 49 Nm.
- **Caution:** — Hand tighten all fuel line connectors and fasteners before applying a wrench to avoid cross threading. Failure to heed this caution may result in property damage.

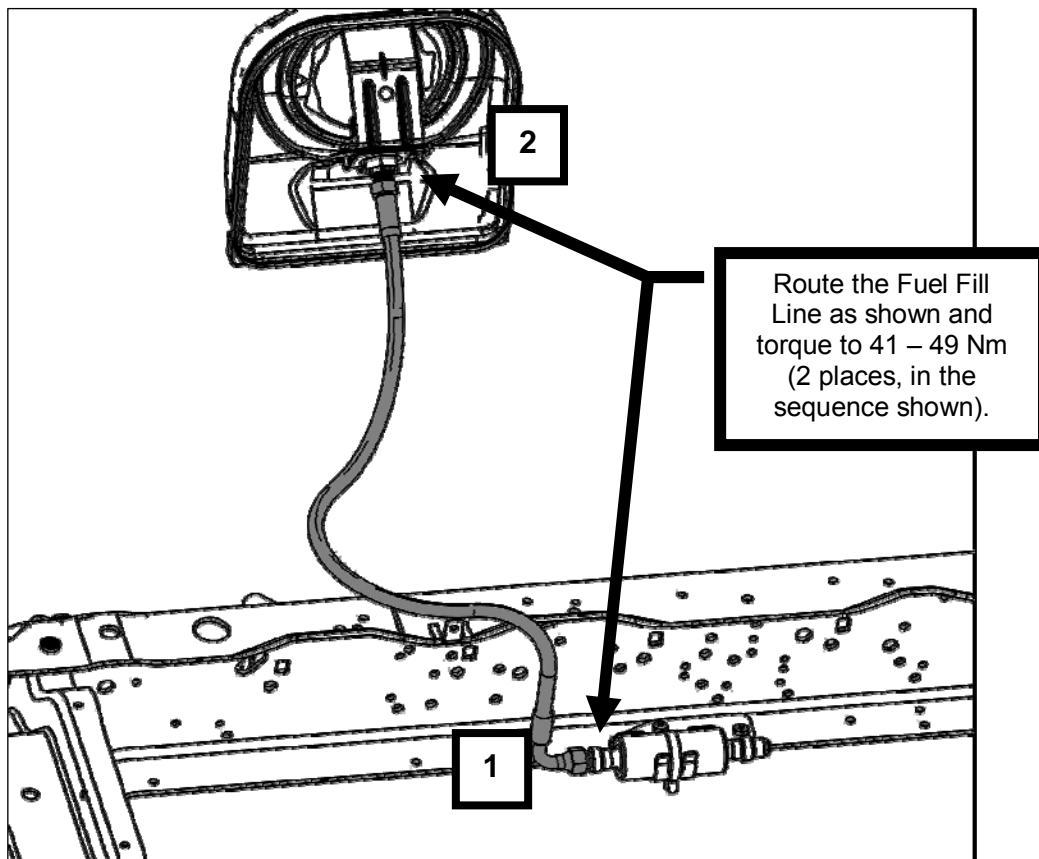

ROUSH CleanTech E-150/250/350 Liquid Propane Autogas 2010 Kit Installation Instructions

7. Retain the Fuel Fill Line (P10C2-9034-BA) to the edge of the body seam by using the Edge Clip Cable Tie (150-40593) found in Hardware Kit C (P10C2-HKC-AA). Route the Cable Tie around the Fill Hose, pull tight, and clip onto the sheet metal edge shown.

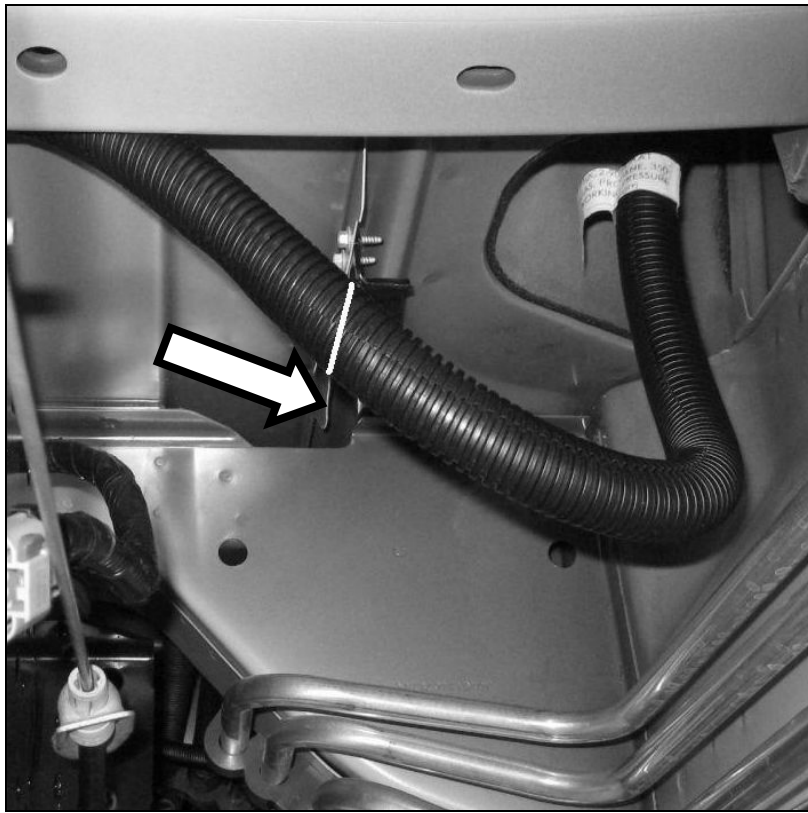

Preparing the Tank Assembly

- ▲ **Caution:** — Use care when removing the protective wrap from the Fuel Tank Heat Shield to avoid the adhesive side of the shield material from folding over and adhering. Should this happen, it becomes impossible to separate the adhered layers without damaging the heat shield material.

To remove the protective wrap, place the heat shield on a suitable flat surface with the silver outer covering facing downward. Beginning at the removal tab, slowly pull the wrap back while holding the shield at its edge to avoid the material folding over and contacting another surface.

**ROUSH CleanTech E-150/250/350 Liquid Propane Autogas
2010 Kit Installation Instructions**

1. Apply one (1) Heat Shield – End Cap (P10C2-1A484C-AA) to the Fuel Tank (P10C2-9K007NM-AB) rear end cap as shown. **Using a rubber mallet, flatten down the edges of the heat shield material to reduce any sharp edges and ensure maximum adhesion to the tank surface.**

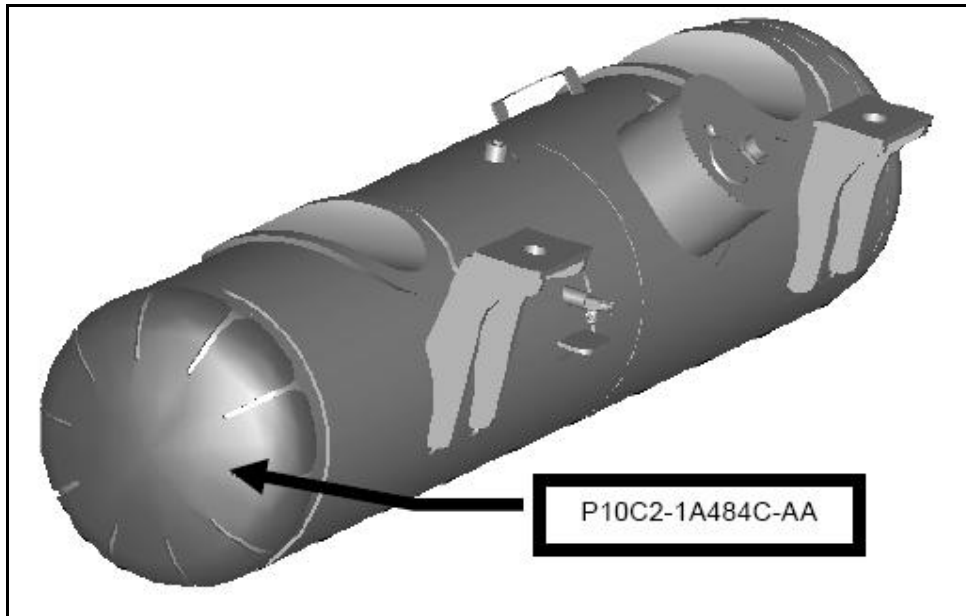

2. Apply the Heat Shield – Rear (P10C2-1A484A-AA) to the rear section of the Fuel Tank (P10C2-9K007NM-AB) as shown. If installed correctly, this heat shield should overlap the rear end cap heat shield. **Using a rubber mallet, flatten down the edges of the heat shield material to reduce any sharp edges and ensure maximum adhesion to the tank surface.**

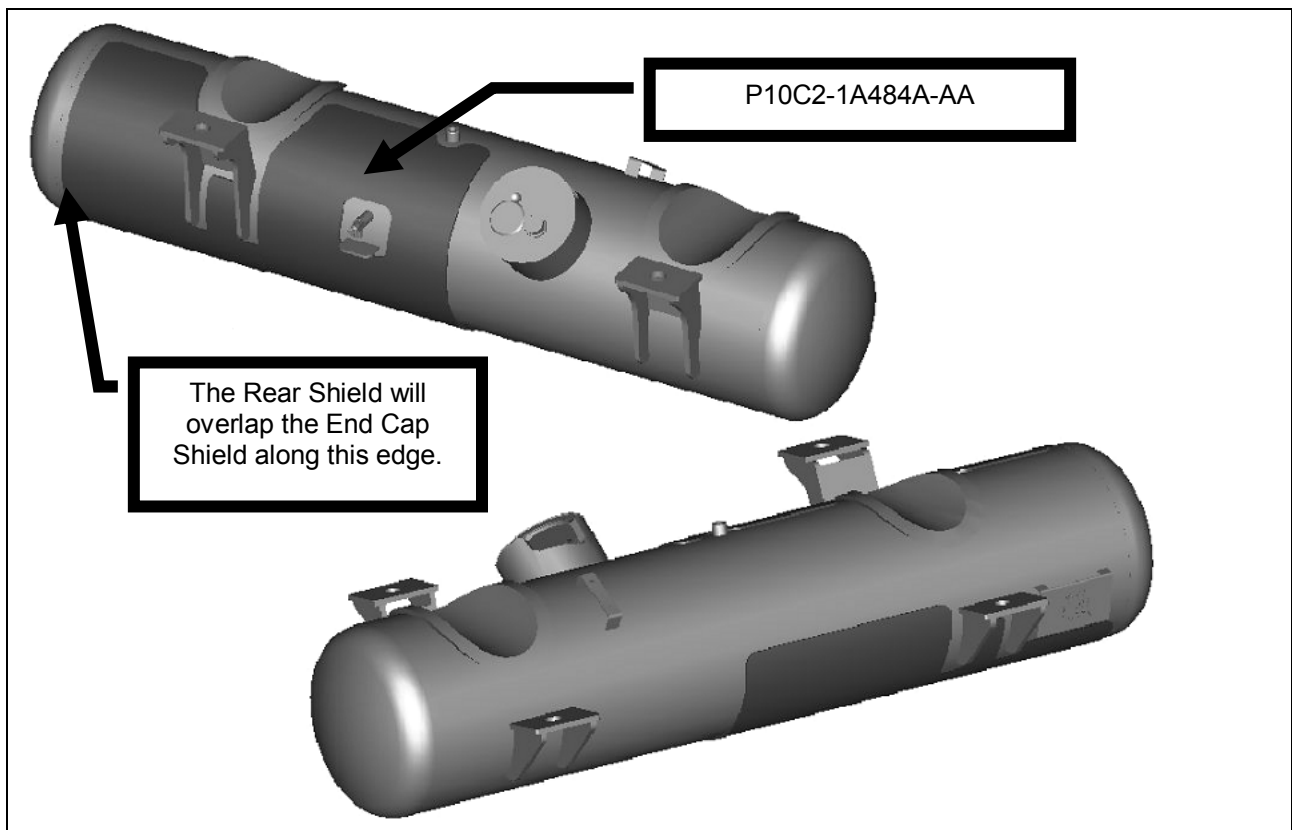

**ROUSH CleanTech E-150/250/350 Liquid Propane Autogas
2010 Kit Installation Instructions**

3. Apply the Heat Shield – Front (P10C2-1A484B-AA) to the forward section of the Fuel Tank (P10C2-9K007NM-AB) as shown. When installed correctly, the Front Heat Shield should mate seamlessly against the Rear Heat Shield. **Using a rubber mallet, flatten down the edges of the heat shield material to reduce any sharp edges and ensure maximum adhesion to the tank surface.**

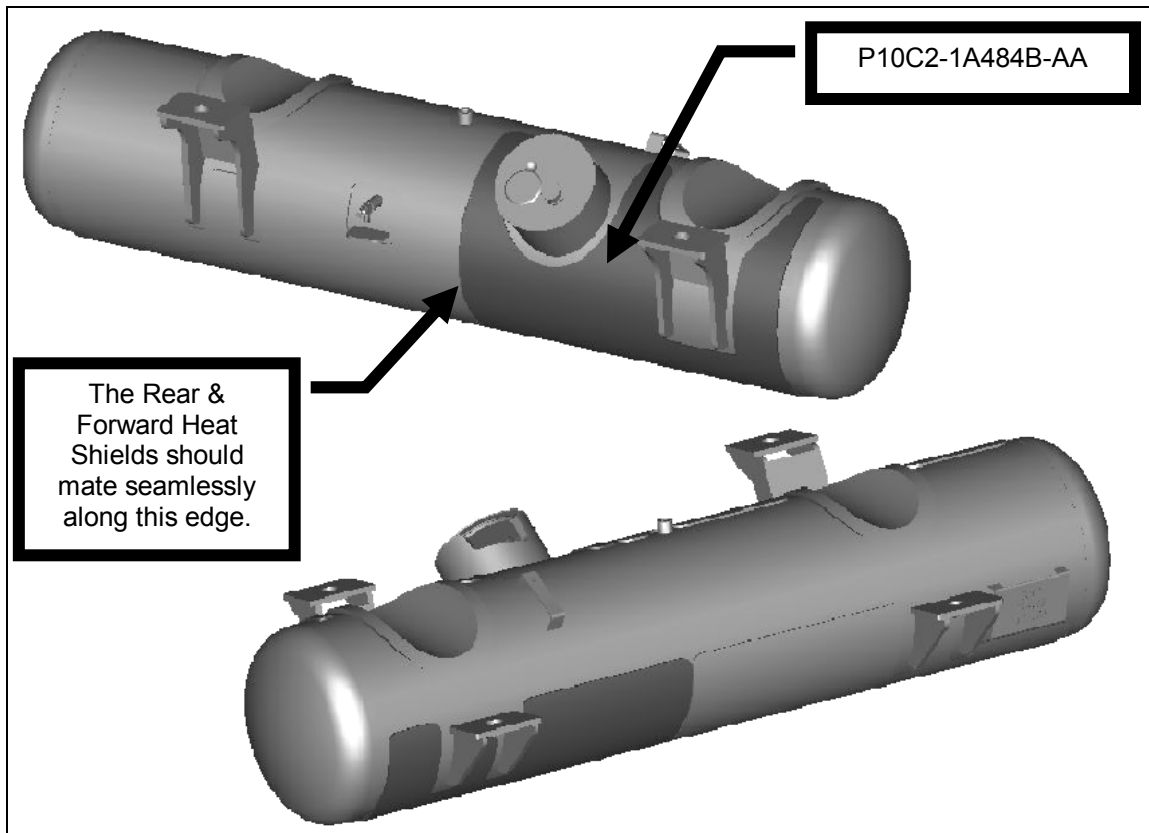

4. Apply one (1) Heat Shield – End Cap (P10C2-1A484C-AA) to the Fuel Tank (P10C2-9K007NM-AB) front end cap as shown. **Using a rubber mallet, flatten down the edges of the heat shield material to reduce any sharp edges and ensure maximum adhesion to the tank surface.**

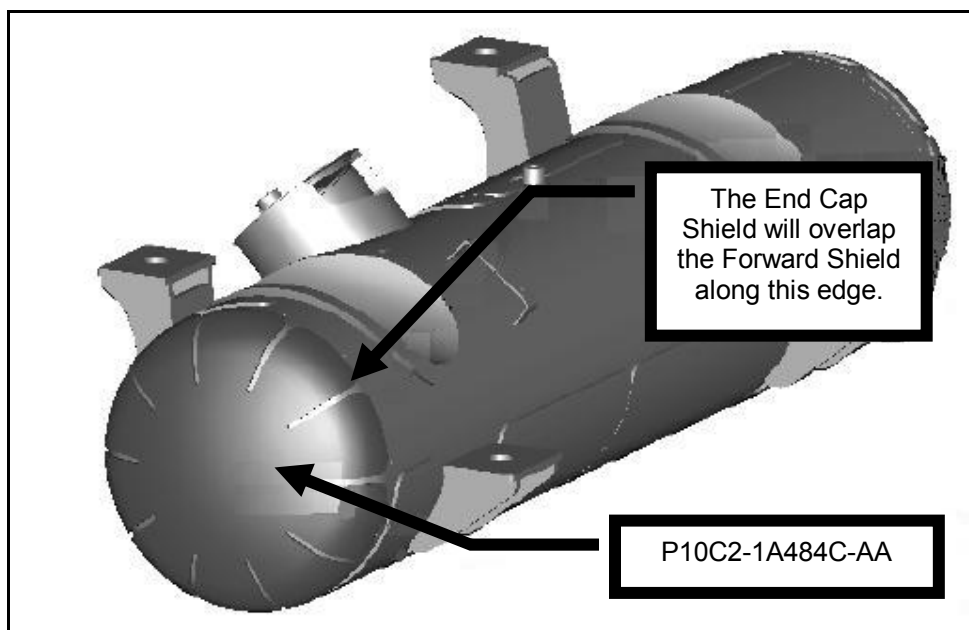

ROUSH CleanTech E-150/250/350 Liquid Propane Autogas 2010 Kit Installation Instructions

- Before making the fuel line connections, check that the Multi-Valve is functioning by briefly applying 12-volt power to the pink and brown wire terminals at the 6-pin connector. The Multi-Valve is functioning if a "click" is heard.
- Install the Fuel Return Line (Item # 1 - P10C2-9D297-AA) and Fuel Supply Line (Item # 2 - P10C2-9J280-AA) through the Tank Collar Grommet (Item # 3 - P10C3-14487-AB). Insert the fuel tank Wiring Harness (which is connected to the fuel tank) into the upper right hole of the grommet. Install the Fuel Fill Line (P10C2-9047-AA) into the remaining hole as shown.

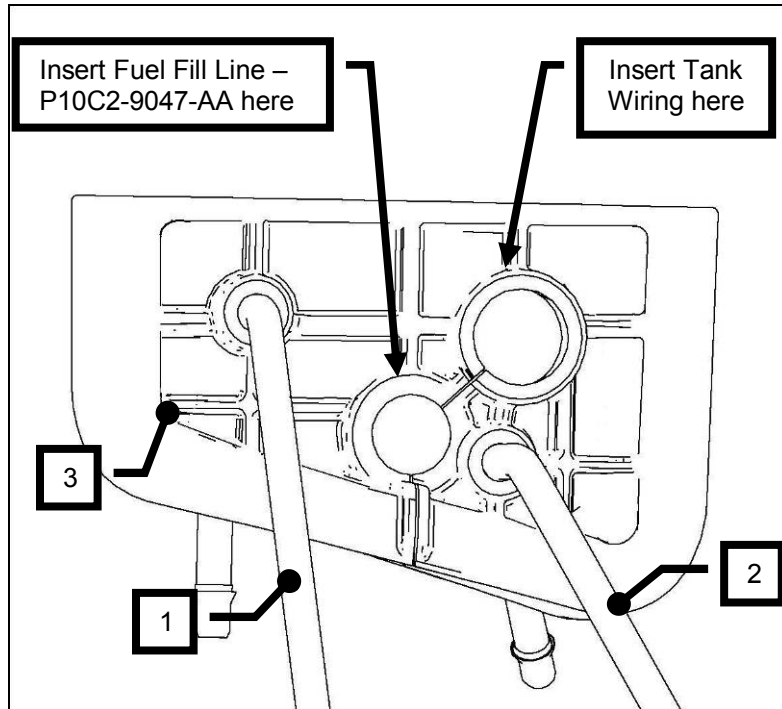

- Assemble the Fuel Fill Line (P10C2-9047-AA) to the 90 degree fitting on the Multivalve as shown. Torque the fill line to 41 – 49 Nm.

Note: Use care when tightening the Fuel Fill Line fitting at the Multi-Valve, to make sure that the 90° fitting at the opposite end of the line (filter end) is facing directly rearward.

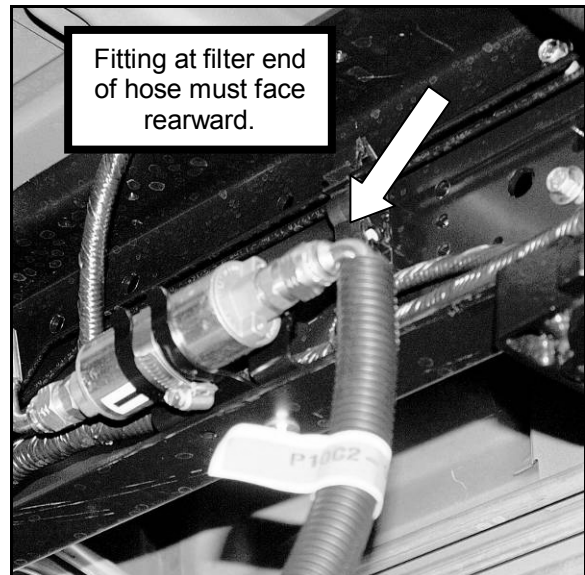
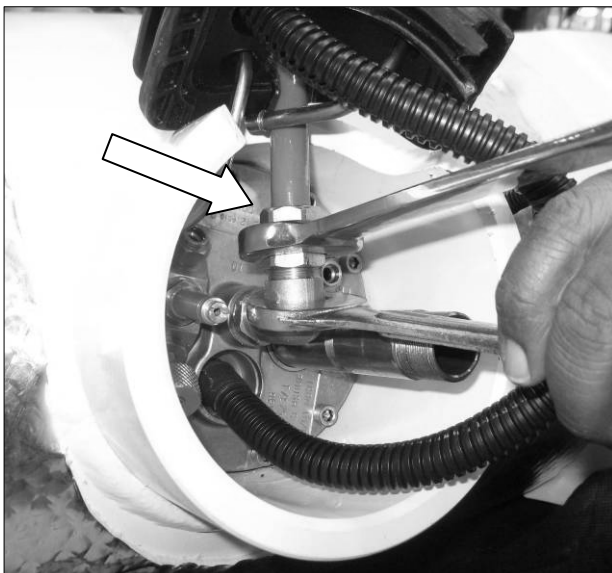

ROUSH CleanTech E-150/250/350 Liquid Propane Autogas 2010 Kit Installation Instructions

8. Remove the protective dust caps from the quick connect fittings on the Multivalve (located inside the tank collar). Install the tank collar grommet into the tank collar opening and push the fuel lines into the quick connect fittings as shown. Give each line a firm pull after installation to ensure that the quick connect fittings have locked into position. Install the 350 PSI Design Pressure Label (P07L3-9A095-1B) onto the top of the Multivalve supply solenoid.

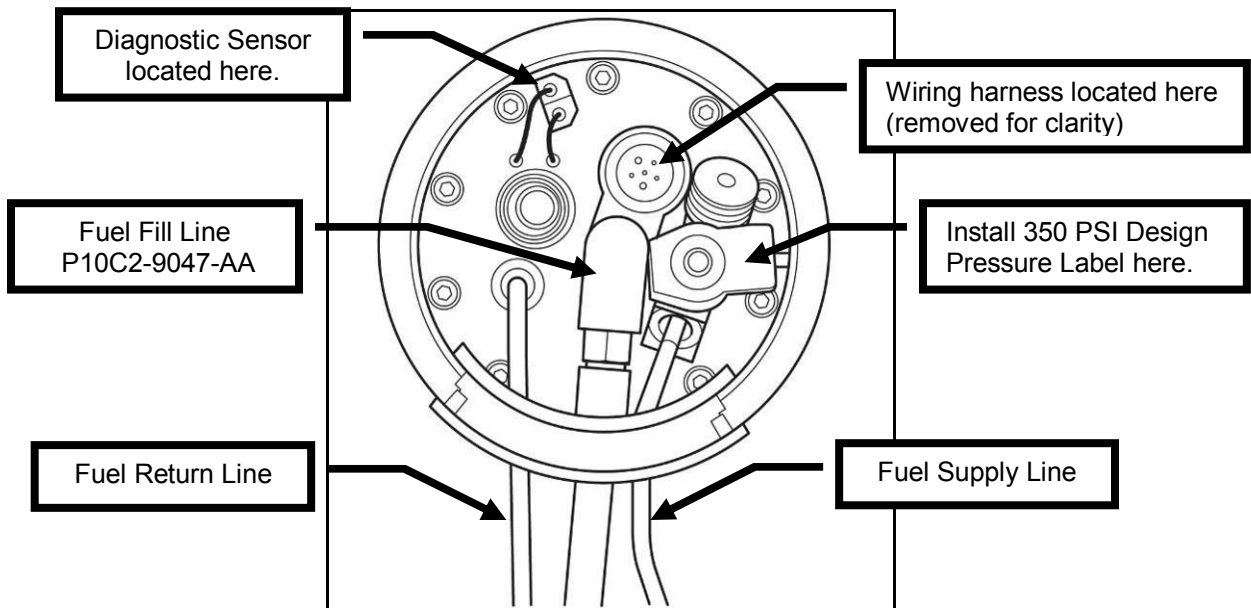

9. Install the fuel line Retention Clip (15-004175) into the top hole on the tank strap bracket as shown. Tap into place lightly with a rubber mallet to fully seat clip. With the collar grommet in position and all of the lines connected to the Multivalve, clip the fuel lines into the fuel line clip as shown.

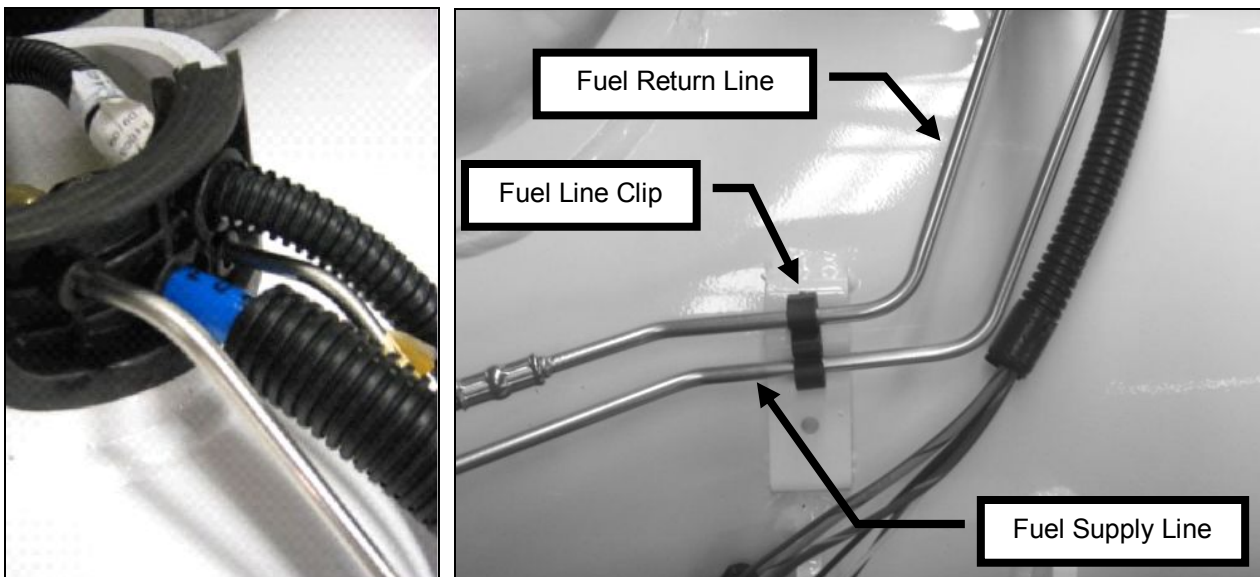

ROUSH CleanTech E-150/250/350 Liquid Propane Autogas 2010 Kit Installation Instructions

10. Once all connections have been made to the Multivalve, and hoses, diagnostic sensor and wiring are neatly arranged inside of the collar, secure the aluminum Collar Cover (item #1) to the tank using the M24 nut (item #2) and o-ring (item #3). All of these parts can be found in a bag that was shipped with the tank.

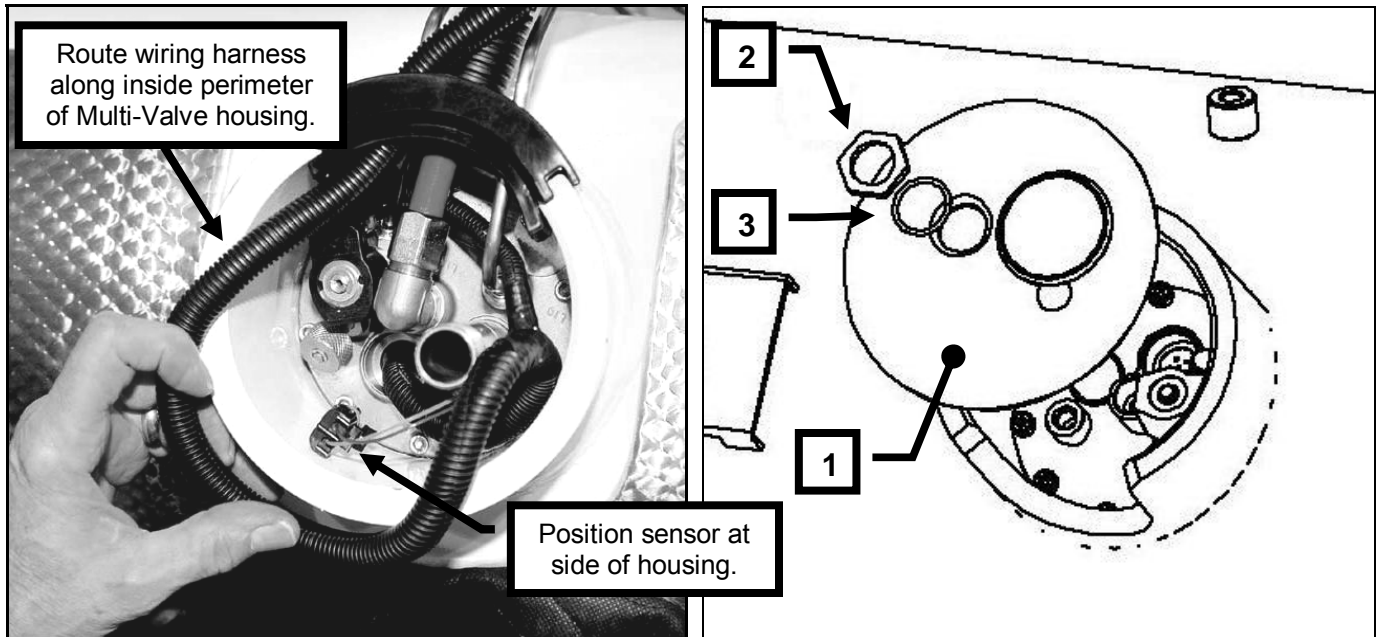

11. Install the Pressure Relief Hose Elbow (P07L3-9K339-AA). Tighten and orient as shown. To position the elbow into the correct orientation, you may need to adjust the lock nut below the elbow. Secure the Pressure Relief Hose (P10C3U-9170-AA) to the elbow with one (1) Constant Tension Clamp (32150000).

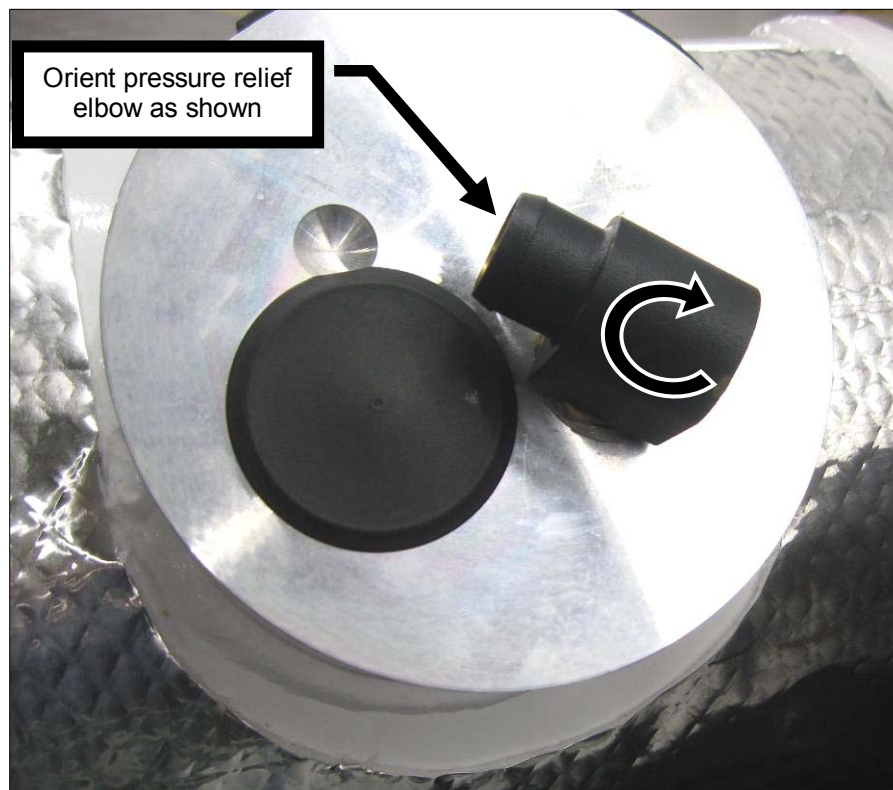

**ROUSH CleanTech E-150/250/350 Liquid Propane Autogas
2010 Kit Installation Instructions**

12. Secure one (1) Rubber Isolator (P07L3-9N052-AA) found in Hardware Kit C (P10C2-HKC-AA) to the top side of each of the four (4) tank mounting brackets using a high strength, fast curing adhesive. This will keep them properly positioned during tank installation.

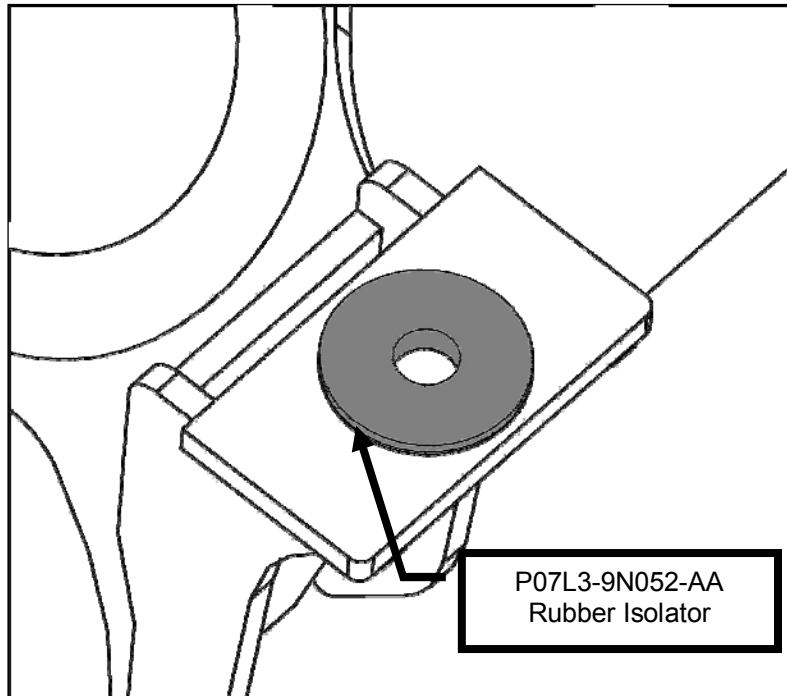

13. Install one (1) Overflow Protection Device Label (P07L3-9A095-BB) onto the tank next to the bleeder valve and one (1) Tank Valve Information Label (P07L3-9A095-JB) close to the Multivalve collar as shown.

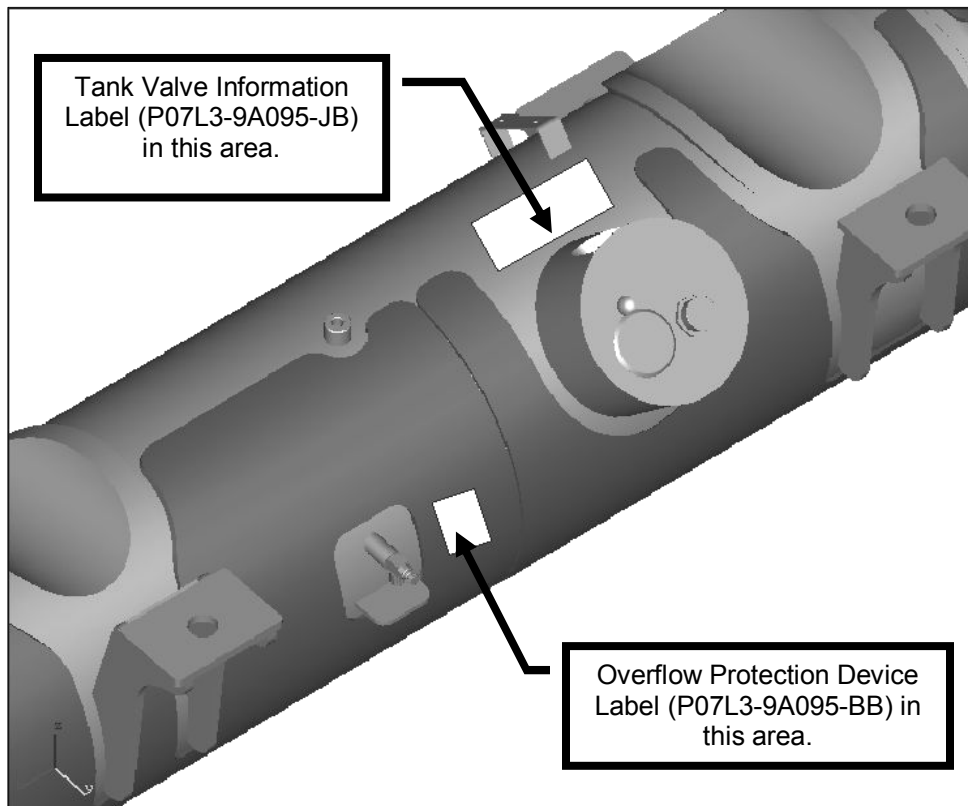

ROUSH CleanTech E-150/250/350 Liquid Propane Autogas 2010 Kit Installation Instructions

Preparing the Frame

The following picture illustrates the tank location from looking up beneath the vehicle between the driveshaft and driver side frame rail, rearward of the transmission and forward of the rear axle assembly. The following steps will refer to each section (A thru D) as each mount location will require unique mounting hardware and assembly procedures.

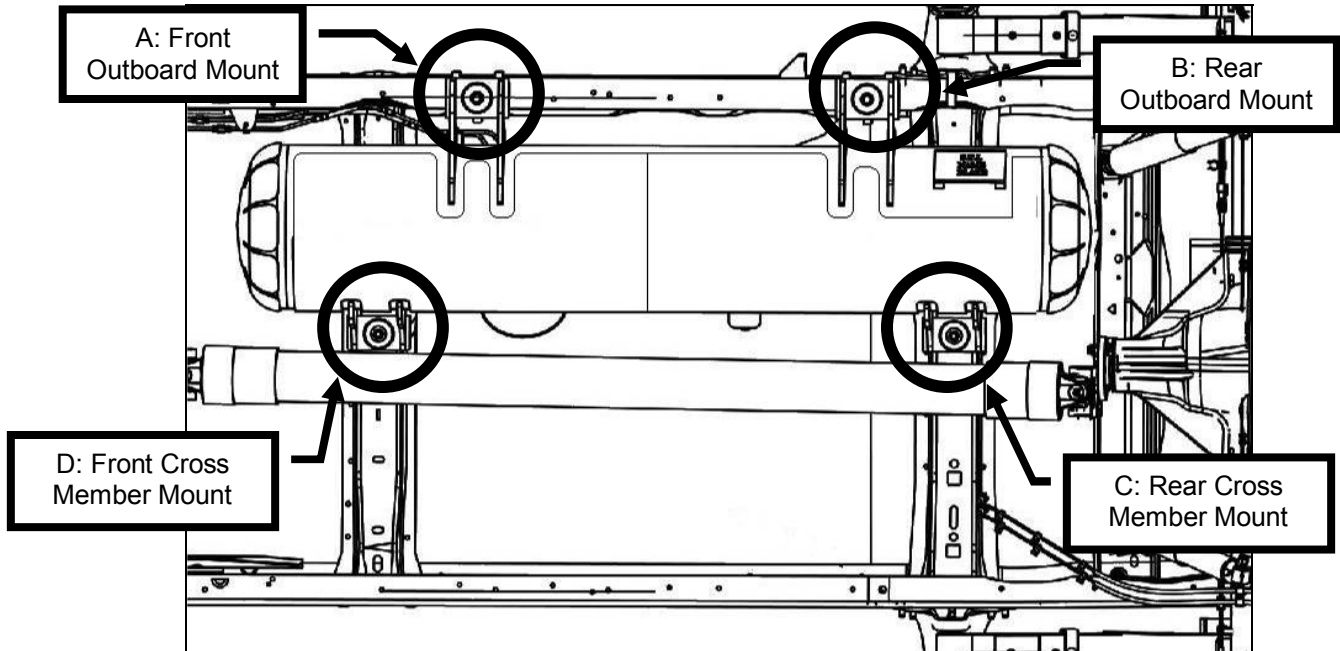

Mounting hardware for each location is shown in the exploded view below. The hardware used on E-150/250 applications is shown below. E-350 vehicles will have unique mounting brackets due to the difference in frame height.

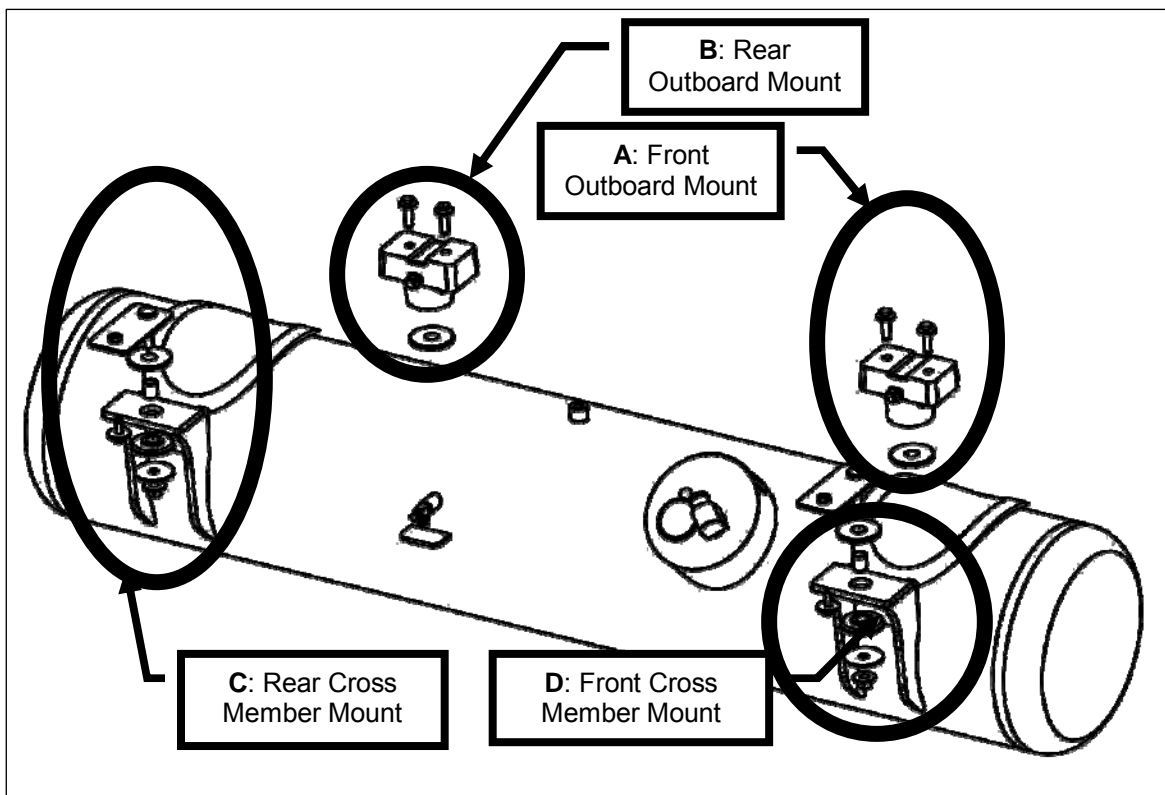

ROUSH CleanTech E-150/250/350 Liquid Propane Autogas 2010 Kit Installation Instructions

Note – Wiring harness retainers protrude through two of the frame rail holes that are to be used in the mounting of the tank. Remove these wiring harness push pin retainers from the frame holes prior to modifying the holes.

1. **Area A: Front Outboard Mount** –Drill the two existing frame holes shown below to 11mm. Debur and coat all bare metal using a premium undercoating. Roush suggests Motorcraft Premium Undercoating (PM-25-A). Install the Front Outboard Frame Tank Mounting Bracket (E-150/250: P10C2-9046-AA or E-350: P10C2HD-9046-AA) using two (2) M10 x 1.5 x 36 (N807239-S437) bolts. These can be found in Hardware Kit C (P10C2-HKC-AA). Torque to 40 - 55 Nm.

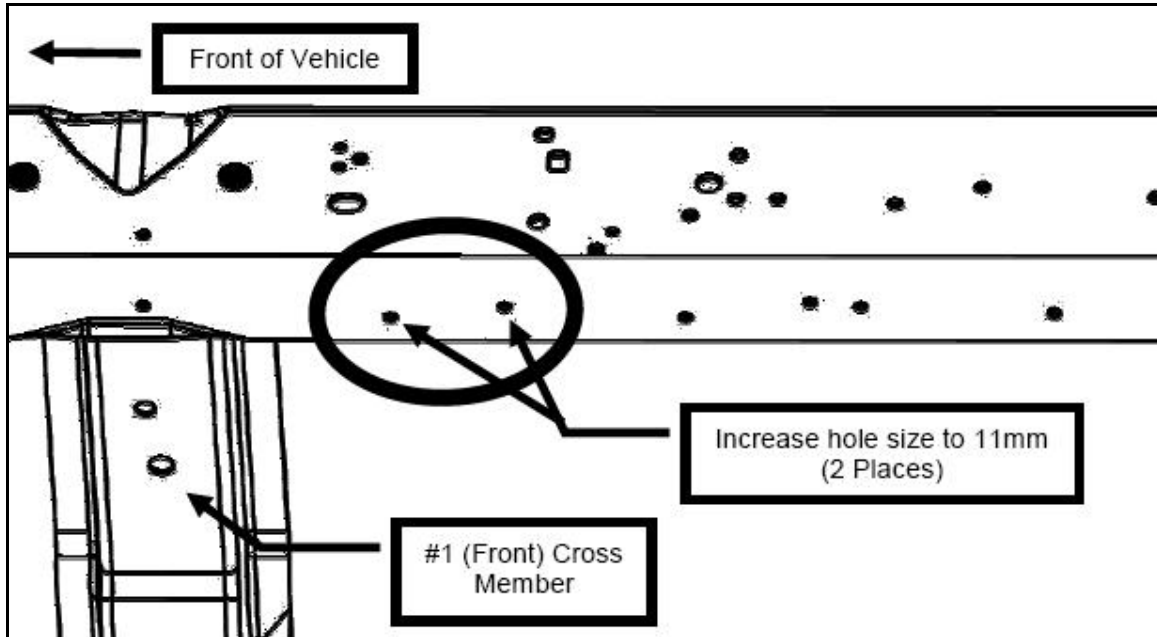

View looking toward the inboard side of the driver side frame rail showing fastener installation into the bracket.

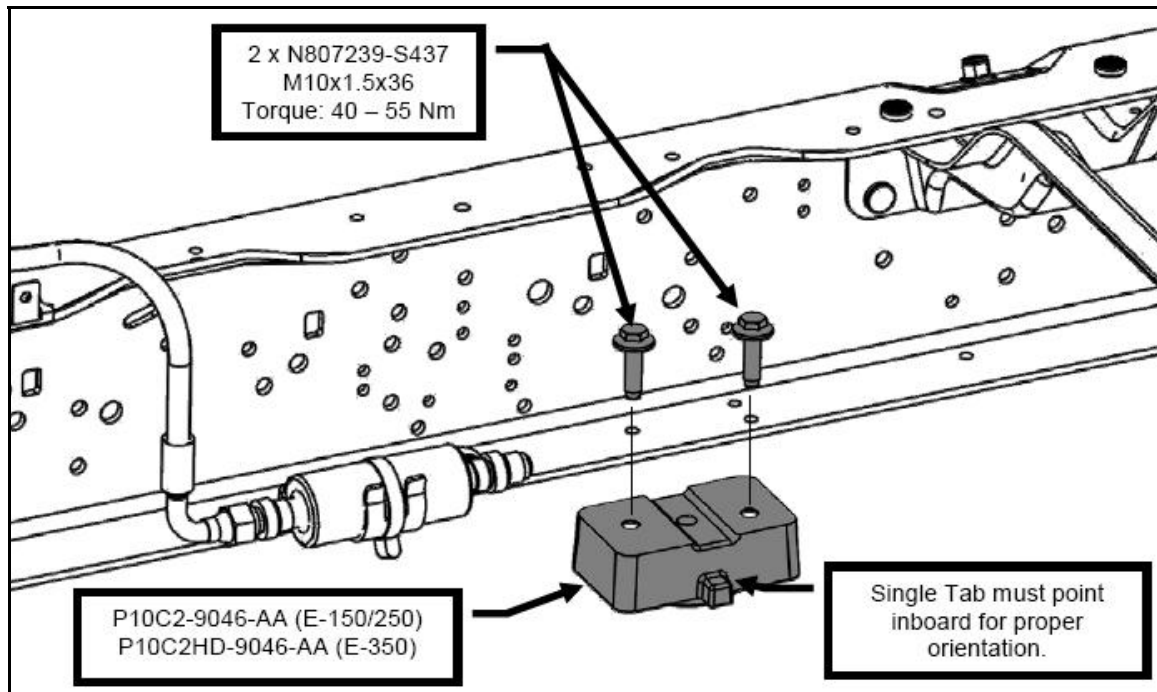

ROUSH CleanTech E-150/250/350 Liquid Propane Autogas 2010 Kit Installation Instructions

Area B: Rear Outboard Mount - Drill the existing frame hole shown below to 11mm. Deburr and coat all bare metal using a premium undercoating. Roush suggests Motorcraft Premium Undercoating (PM-25-A). Install the Rear Outboard Frame Tank Mounting Bracket (E-150/250: P10C2-9045-AA or E-350: P10C2HD-9045-AA) using two (2) M10 x 1.5 x 36 (N807239-S437) bolts. These can be found in Hardware Kit C (P10C2-HKC-AA). Torque to 40 - 55 Nm.

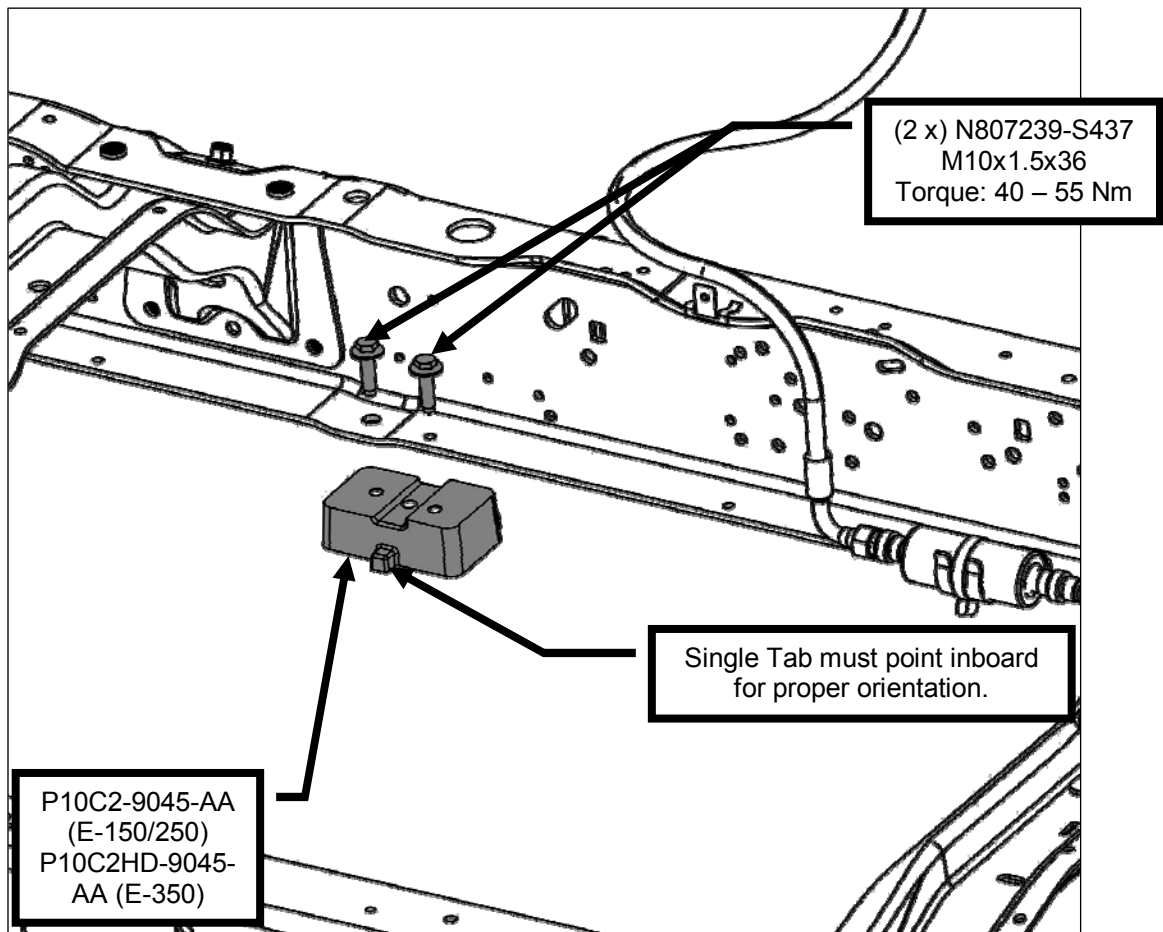
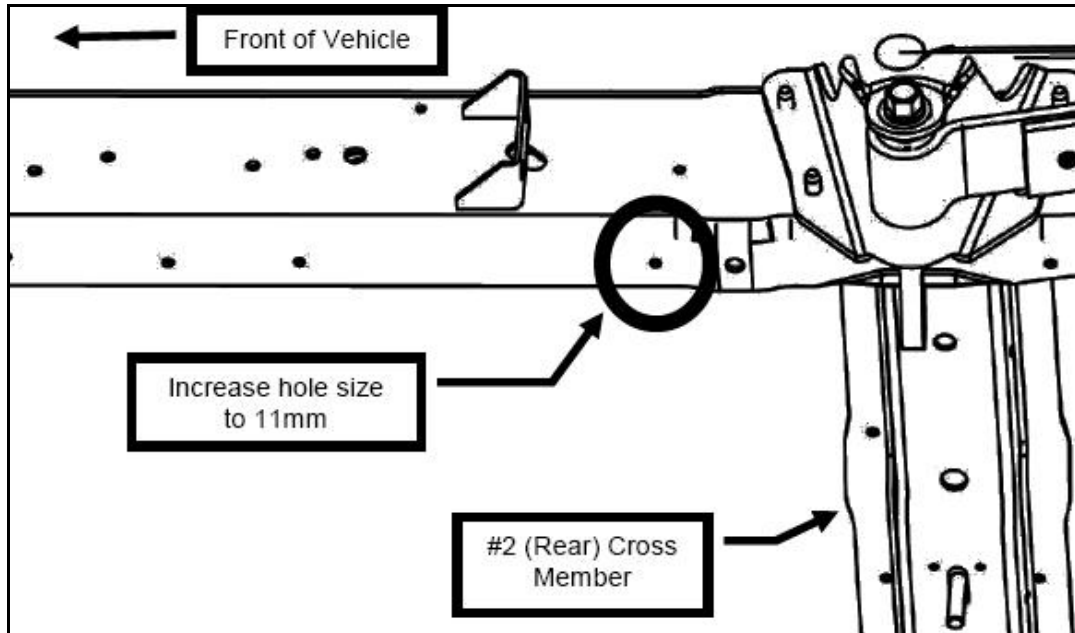

ROUSH CleanTech E-150/250/350 Liquid Propane Autogas 2010 Kit Installation Instructions

- Area C: Rear Cross Member Mount** - Install the Cross Member Tank Mounting Bracket (P10C2-9A041-AA) onto the rear cross member. Loosely install the M8 x 1.25 x 28 bolt (R18020060-00-AA). Do not fully tighten this bolt as adjustability of the bracket will be necessary during tank installation.

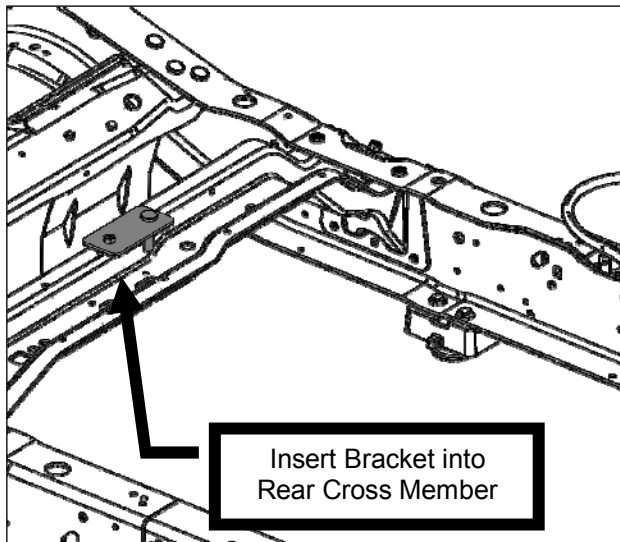

View looking from above frame.

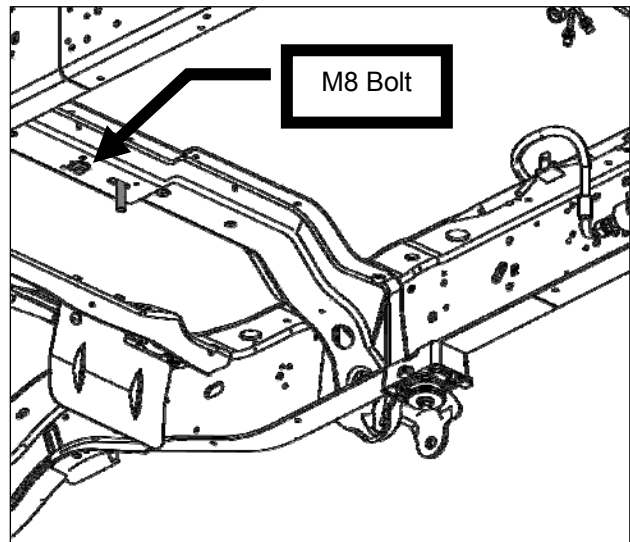

View looking from below vehicle.

- Area D: Front Cross Member Mounting** - Install the cross member tank mounting bracket (P10C2-9A041-AA) onto the front cross member. Hand tighten the M8 x 1.25 x 28 fastener (R18020060-00-AA) to keep the bracket in position. Do not fully tighten this bolt as adjustability of the bracket will be necessary during tank installation.

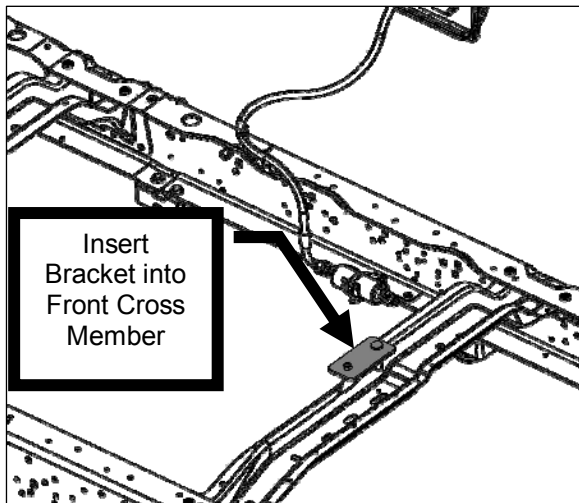

View looking from above frame.

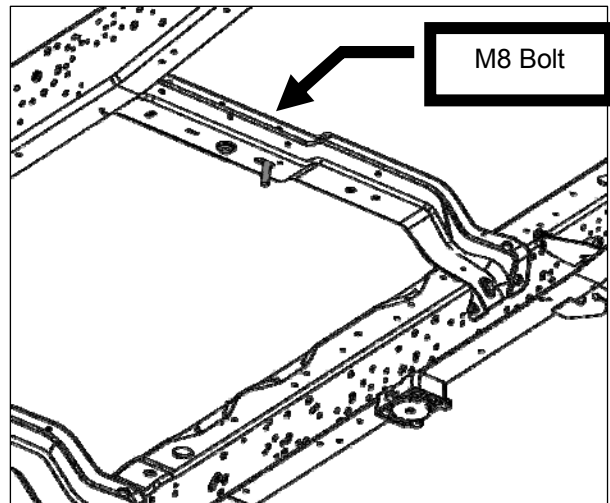

View looking from below vehicle.

Installing the Fuel Tank Assembly

- ⚠ Caution:** — Hand tighten all fuel line connectors and fasteners before applying a wrench to avoid cross threading. Failure to heed this caution may result in property damage.
- With the fuel lines, fuel fill line, pressure relief hose, remote bleeder valve line and wiring harness tucked up against the fuel tank, slowly begin to raise the tank into position. Stop approximately 12" – 18" from its final position. This will allow for room to complete steps 2 through 4.

ROUSH CleanTech E-150/250/350 Liquid Propane Autogas 2010 Kit Installation Instructions

2. Connect the 6 pin connector located on the Roush Vehicle Harness (P10C2-3075-AA) to the tank harness connector as shown.

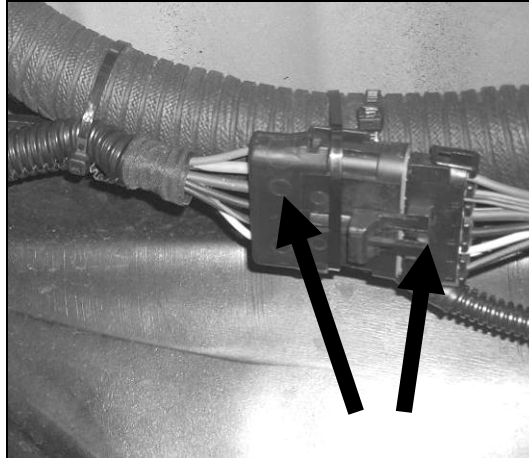

After the two 6 pin connectors are mated, secure the connectors to the main body harness with zip ties.

3. Route the Fuel Fill Line (P10C2-9047-AA) from the tank collar toward the fuel fill filter as shown. This line will be secured to the filter once the tank is fully installed into the vehicle.

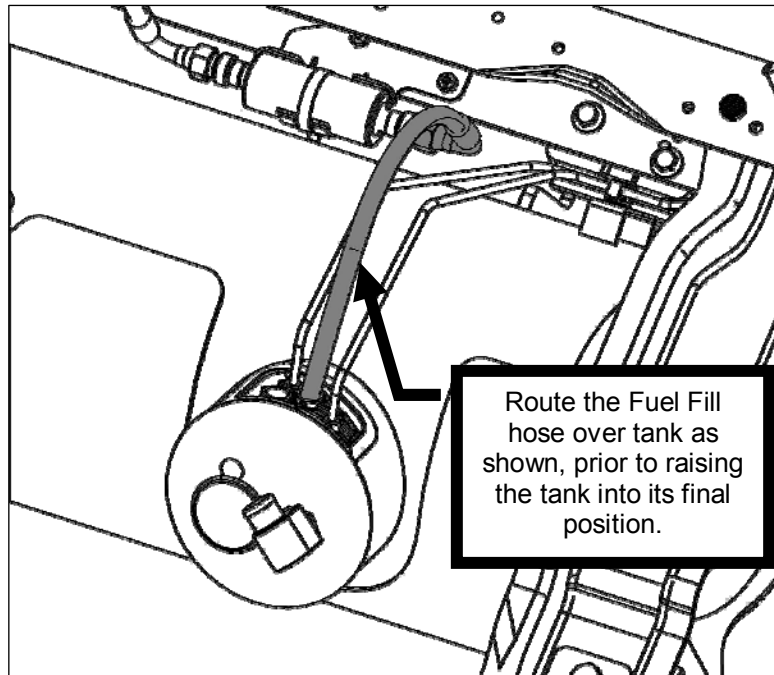

ROUSH CleanTech E-150/250/350 Liquid Propane Autogas 2010 Kit Installation Instructions

4. Route the Pressure Relief Hose (P10C2-9170-AA) and the Remote Bleeder Valve Line (P11C2-1J001-AA) over the frame rail toward the rear wheel opening as shown.

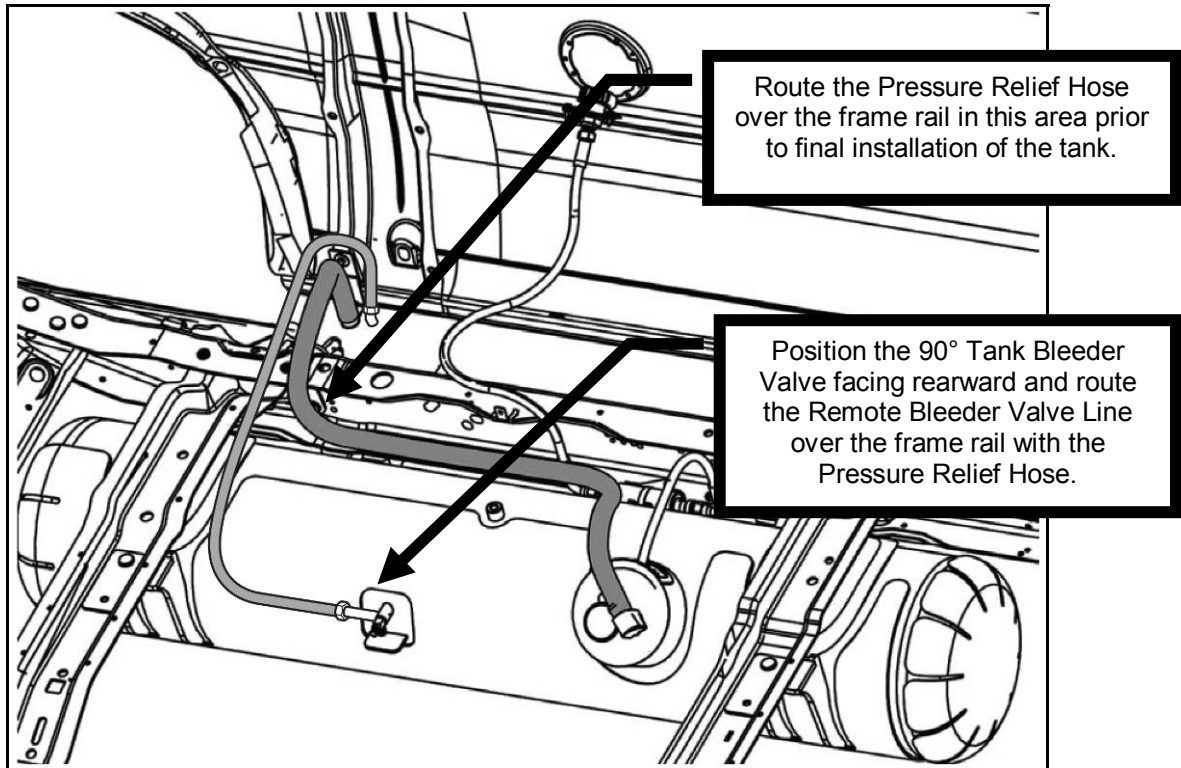

5. Raise the tank into position, being careful to align the mounting holes on the tank with the four respective mounting brackets before fully seating on four locations.

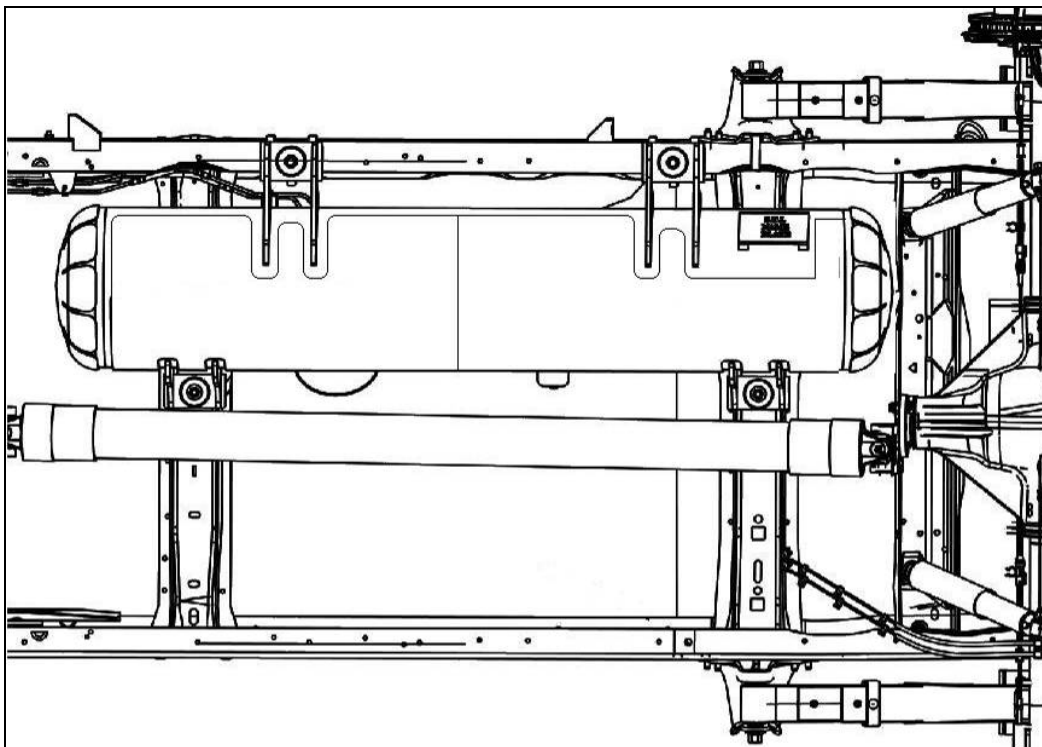

Bottom view illustrating a fully installed tank.

**ROUSH CleanTech E-150/250/350 Liquid Propane Autogas
2010 Kit Installation Instructions**

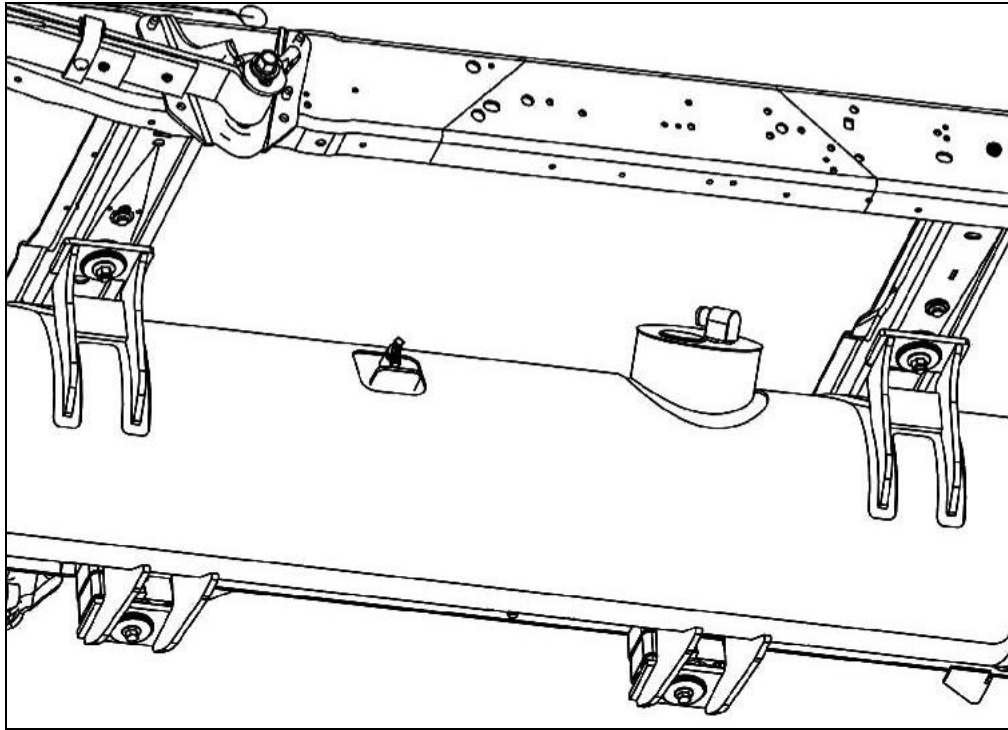

View of inboard cross member mounts (driveshaft removed for clarity).

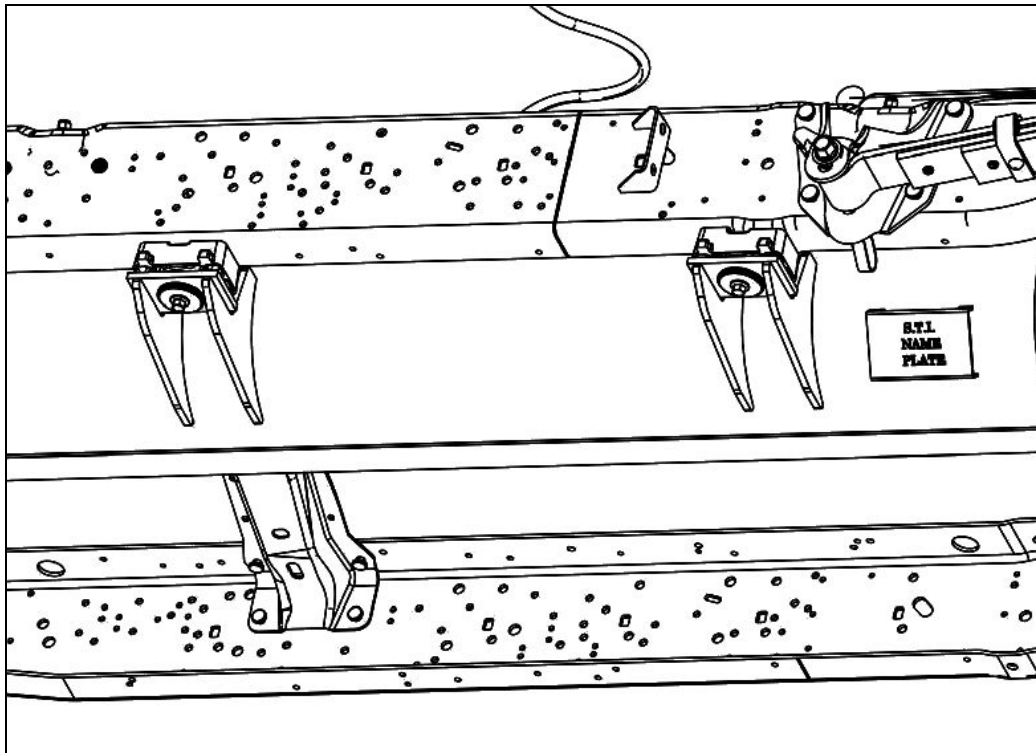

View of outboard frame mounts.

ROUSH CleanTech E-150/250/350 Liquid Propane Autogas 2010 Kit Installation Instructions

6. Once all of the tank mounting brackets are aligned and seated firmly against their mating components on the frame and cross members, install four (4) Crush Limiters (P10C3-11293-BA) and the four (4) remaining Tank Mounting Isolators (P07L3-9N052-AA) into the underside holes on the tank mounting brackets (4 places). These can be found in Hardware Kit C (P10C2-HKC-AA).

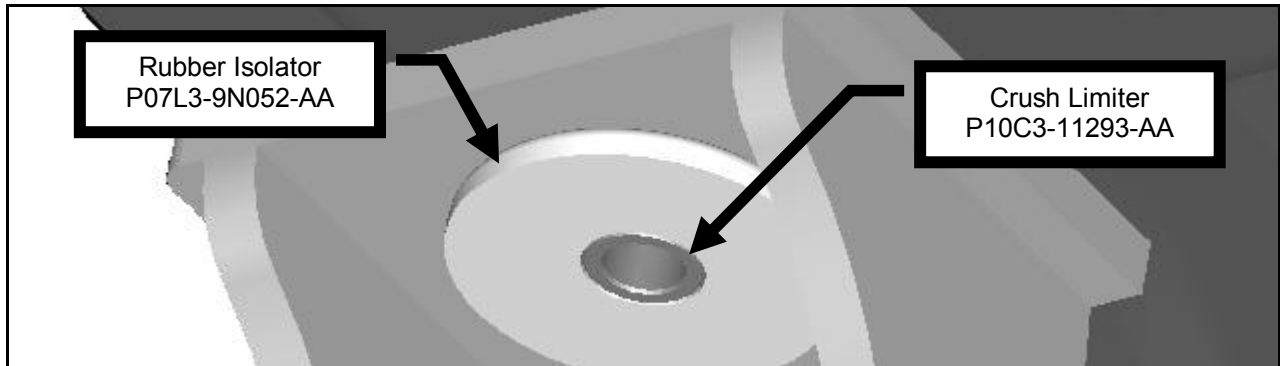

7. **Outboard Frame Mounts** - Loosely install the M12 x 50 Bolts (W709529-S437) and Washers (P07L3-3932-AA) found in Hardware Kit C (P10C2-HKC-AA) – 2 Places. Do NOT tighten the bolts at this time. Once all four tank mounting fasteners have been installed into their respective brackets, these bolts will be fully torqued.

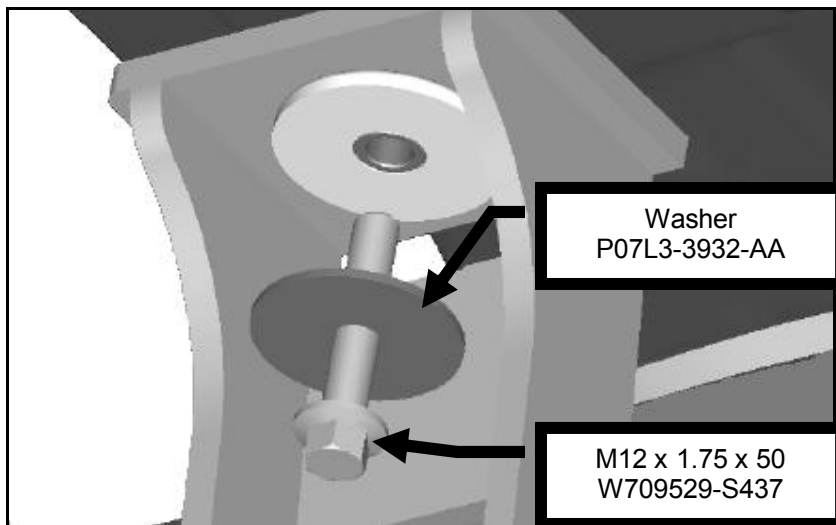
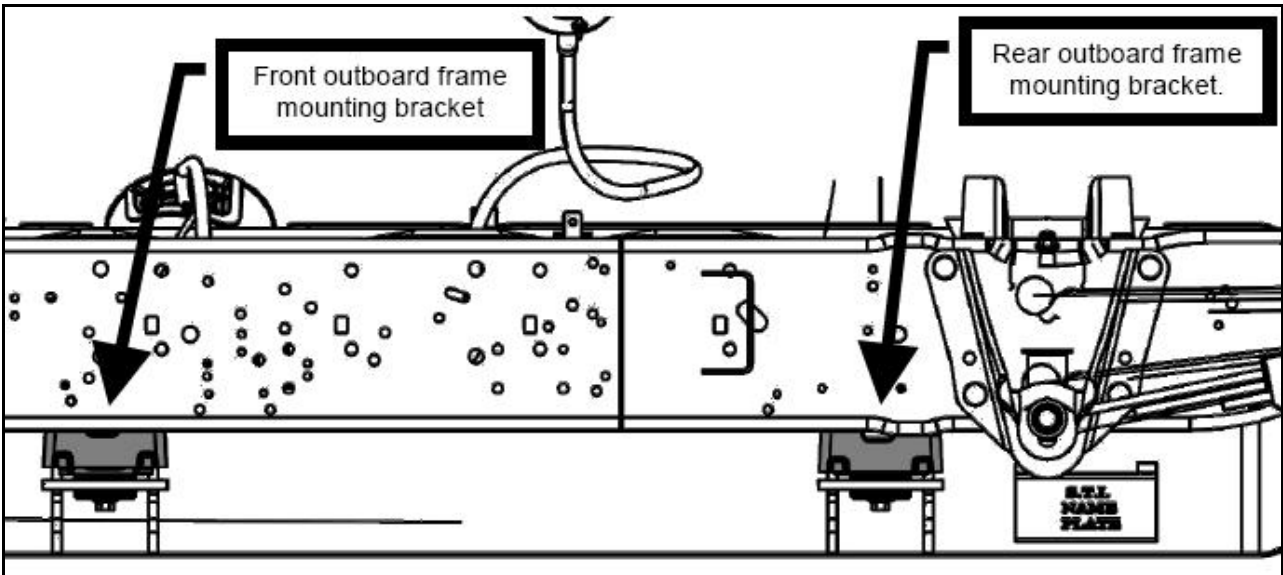

ROUSH CleanTech E-150/250/350 Liquid Propane Autogas 2010 Kit Installation Instructions

8. **Cross Member Mounts** - Loosely install the M12 Nuts (N807479-S101) and Washers (P07L3-3932-AA) found in Hardware Kit C (P10C2-HKC-AA) – 2 Places.

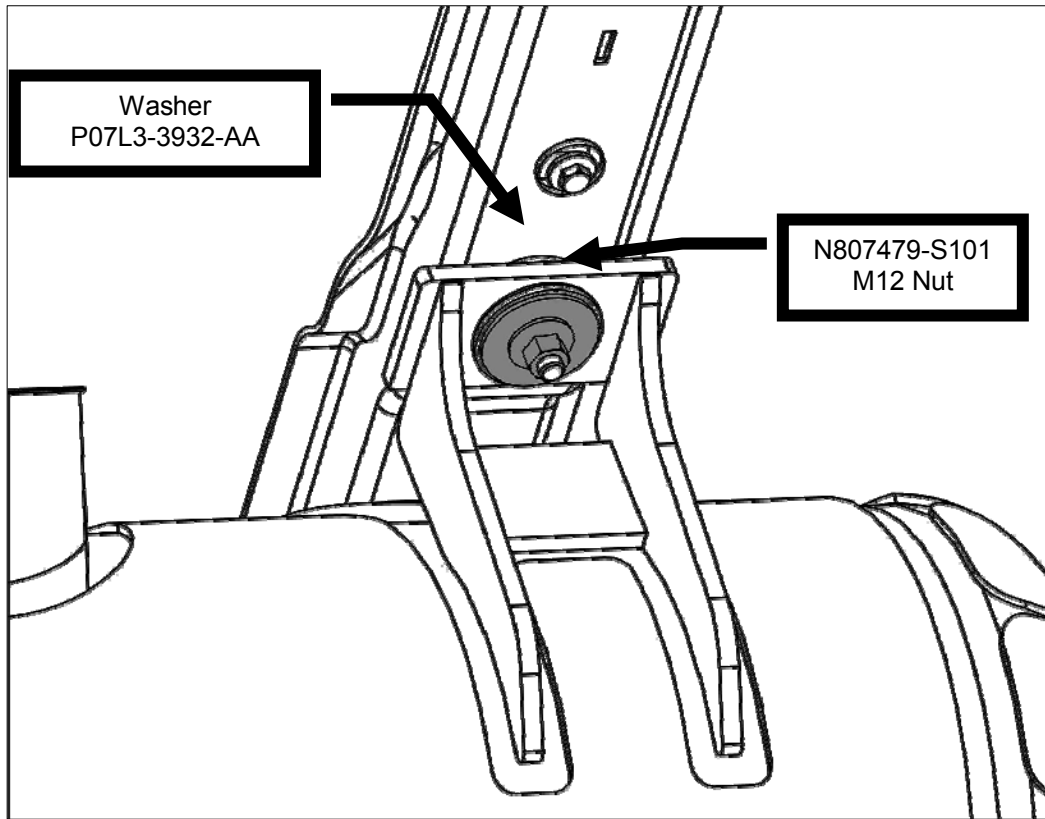

9. Once all tank mounting fasteners have been installed, torque all M12 fasteners (2 Bolts & 2 Nuts) to 80 – 90 Nm. On both the front and rear cross member mounting brackets, torque the M8 bolts to 20 – 30 Nm.

⚠ Caution: — Hand tighten all fuel line connectors and fasteners before applying a wrench to avoid cross threading. Failure to heed this caution may result in property damage.

10. With the fuel filter fill line routed to the filter outlet, hand tighten the fuel filter to tank line and then torque to 41-49 Nm. Use caution to ensure this line does not become kinked when tightening.

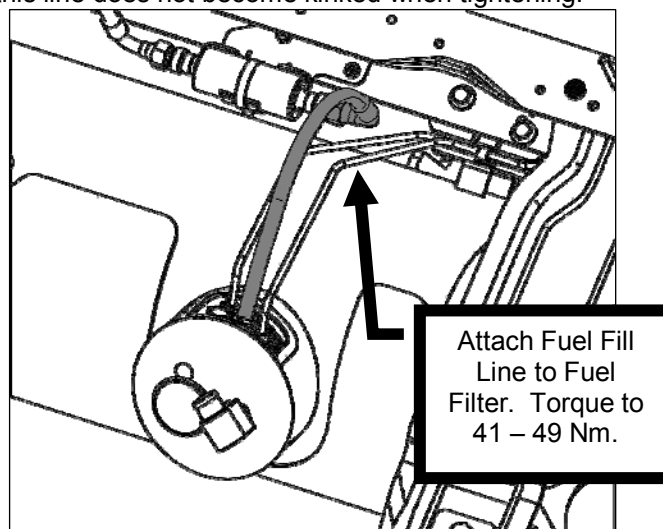

ROUSH CleanTech E-150/250/350 Liquid Propane Autogas 2010 Kit Installation Instructions

Installing the New Forward Fuel Lines

⚠ Caution: — Hand tighten all fuel line connectors and fasteners before applying a wrench to avoid cross threading. Failure to heed this caution may result in property damage.

1. Install the Fuel Jumper Line - FRPCM to RH Fuel Rail (P10C2-9E964-AA) as shown below. Verify that this line connects to the **LOWER RIGHT PORT** located on the FRPCM as shown. Torque line fittings to 18 – 22 Nm.

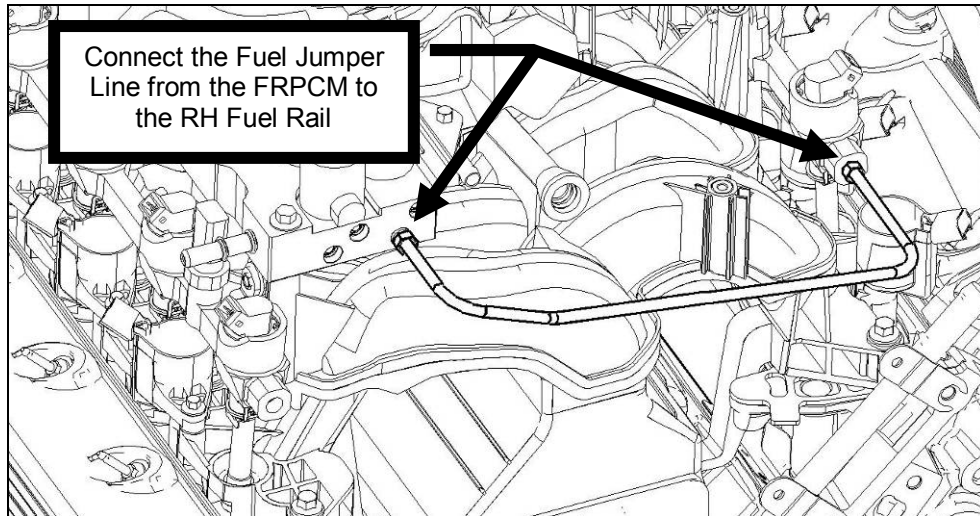

2. Install the Forward Supply Fuel Line (P10C2-9F911-AA) shown in **GREY** and the Forward Return Fuel Line (P10C2-9F912-AA) shown in **BLACK**. Following the stock 5/8" VMV line, route both lines above the LH exhaust heat shield, through the transmission bellhousing bracket and into the engine compartment. Do not close the bellhousing bracket at this time as this will be done once all connections to the FRPCM are complete.

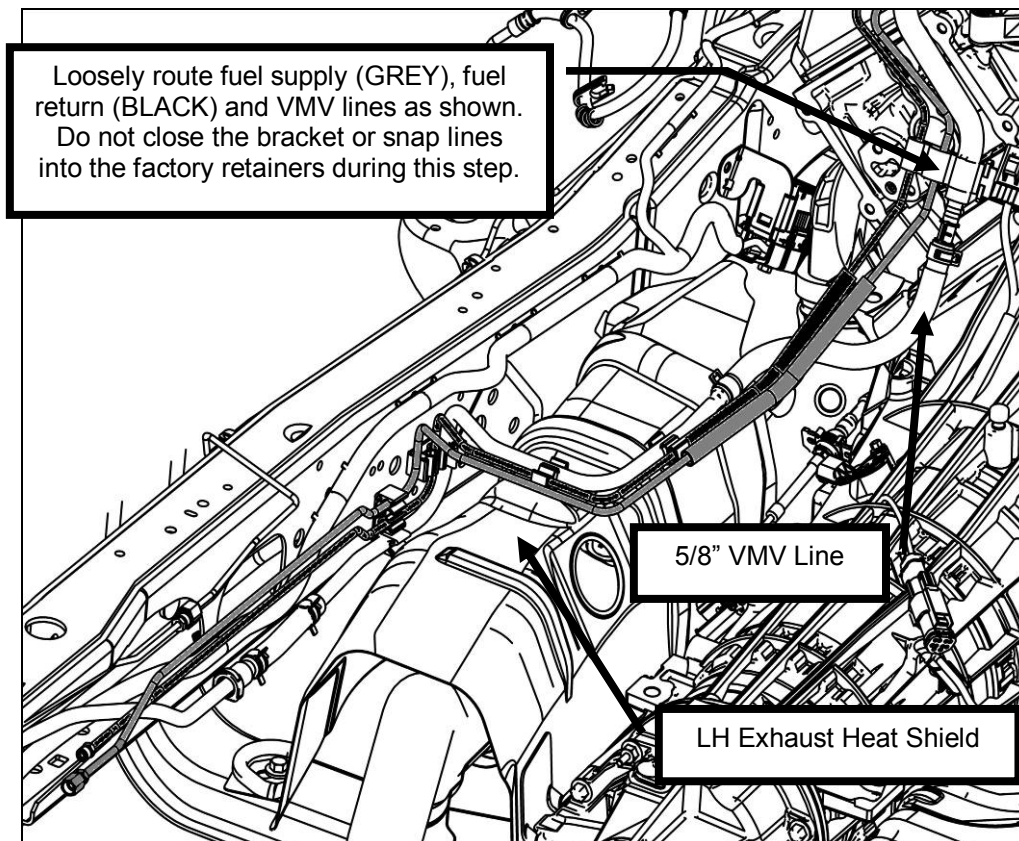

ROUSH CleanTech E-150/250/350 Liquid Propane Autogas 2010 Kit Installation Instructions

3. Remove the factory fuel line clip that originally held the VMV line & gasoline supply line together. Replace it with the triple sectioned Fuel Line Retainer (P10C2-9A317-AA) found in Hardware Kit B (P10C2-HKB-AA). This Fuel Line Retainer (P10C2-9A317-AA) will support the VMV, Forward Fuel Supply and Return Lines in the "straight" section of lines located directly above the LH exhaust heat shield.

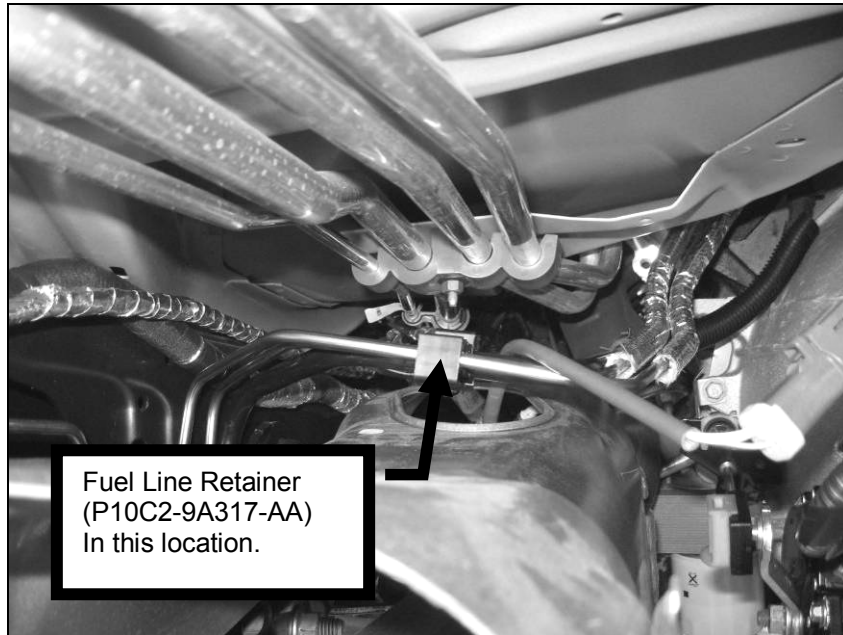

4. Install three (3) "Thin" EPDM Sleeves (1/4" to 3/8" - P07L3-9C328-BA) found in Hardware Kit B (P10C2-HKB-AA) onto the Fuel Return Line before inserting this line into the factory fuel line retainer clips in the areas shown. Install the Fuel Return Line (BLACK) into the clips in three places ("A", "B" & "C") ensuring that each has an EPDM sleeve installed to keep the line snug inside the retaining clip. Install the Fuel Supply Line (GREY) into locations "D" & "E" with no EPDM Sleeve.

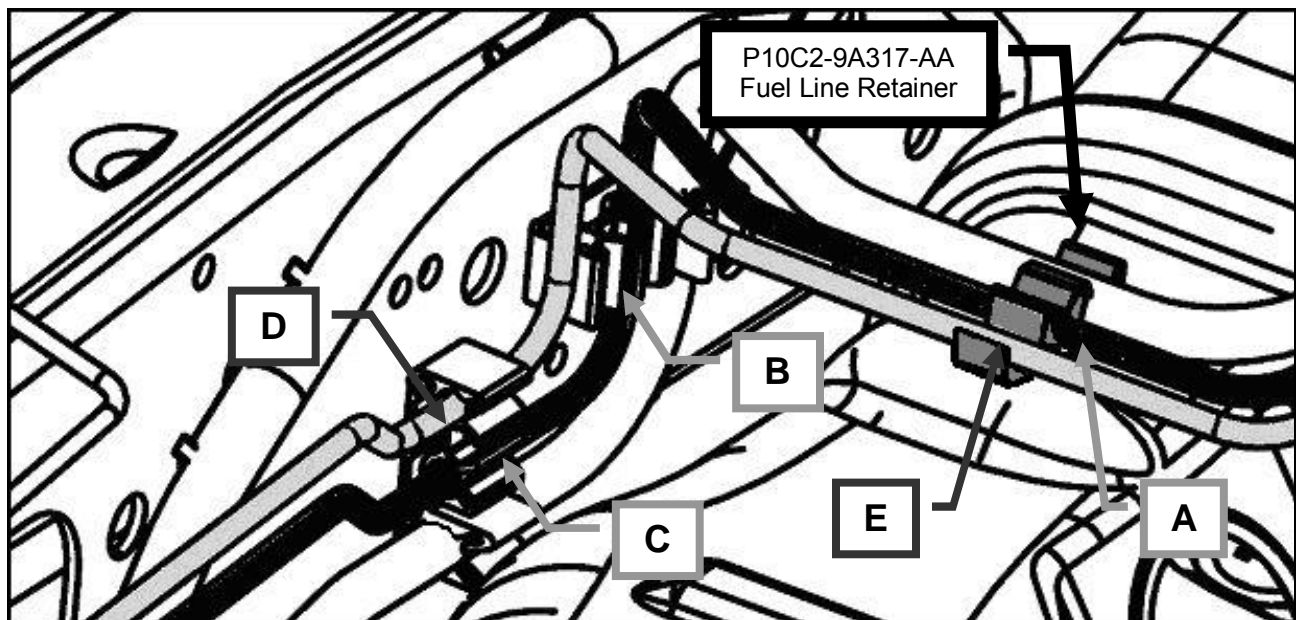

ROUSH CleanTech E-150/250/350 Liquid Propane Autogas 2010 Kit Installation Instructions

5. Install the Double Snail Clip (15-004175) into the Fuel Line Support Bracket (P10C2-9G290-AA). These can be found in Hardware Kit B (P10C2-HKB-AA).

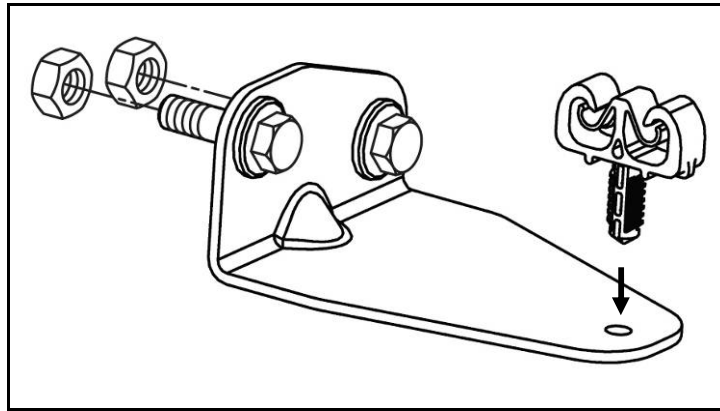

6. Attach the Fuel Line Support Bracket to the frame as shown in the two illustrations below using two (2) M8 nuts (W520413-S309) included in Hardware Kit B (P10C2-HKB-AA). Torque to 20 – 30 Nm.

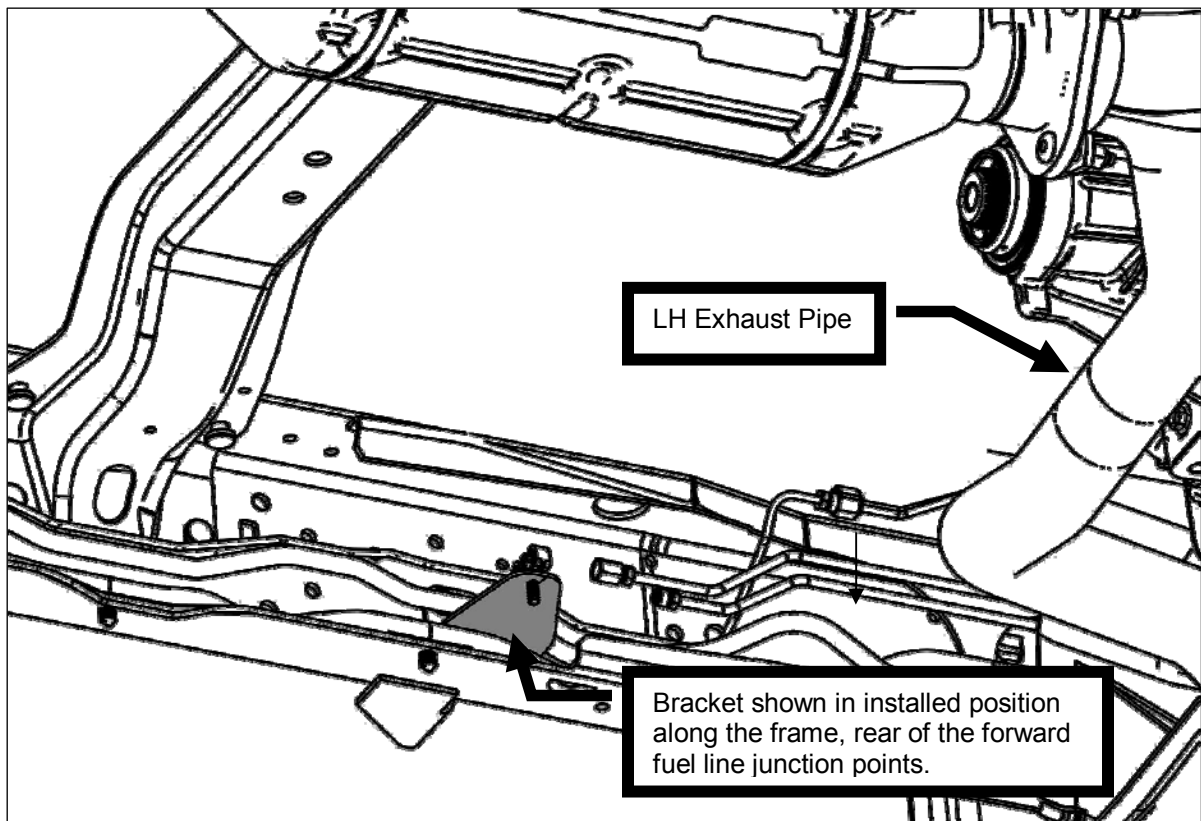

ROUSH CleanTech E-150/250/350 Liquid Propane Autogas
2010 Kit Installation Instructions

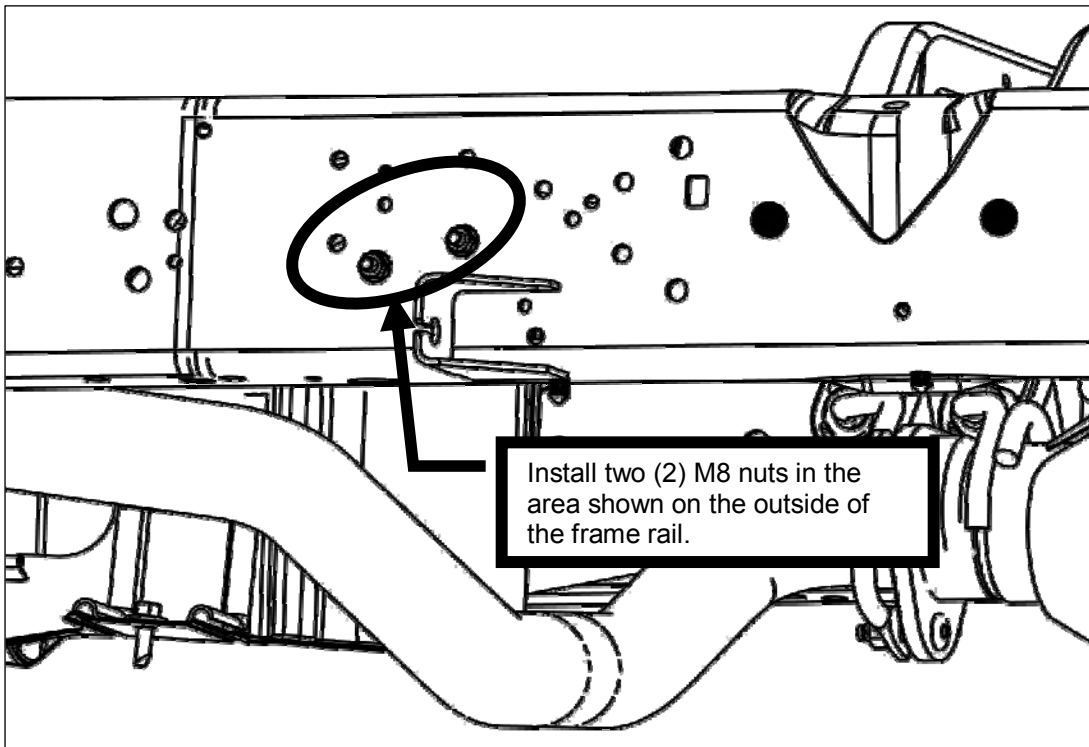

⚠ Caution: — Hand tighten all fuel line connectors and fasteners before applying a wrench to avoid cross threading. Failure to heed this caution may result in property damage.

11. Connect the Fuel Supply and Return Lines from the tank to the forward fuel lines previously installed. Torque line fittings to 18-22 Nm. (Note: Match color tags on mating lines for proper routing). Clip the lines into the Double Snail Retaining Clip on the Fuel Line Support Bracket previously installed. Add one (1) 'Thick' EPDM Sleeve (P07L3-9C328-AA) found in Hardware Kit B (P10C2-HKB-AA) to the brake line in the area shown below.

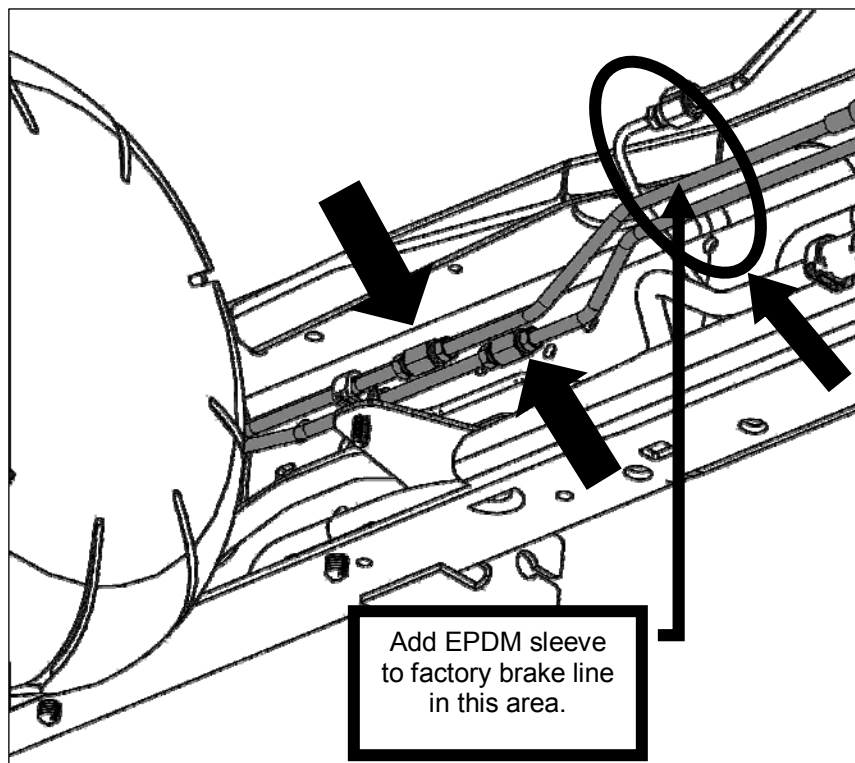

ROUSH CleanTech E-150/250/350 Liquid Propane Autogas 2010 Kit Installation Instructions

7. Install the Forward Fuel Return Line (P10C2-9F912-AA Blue Tag) into the **LOWER LEFT PORT** on the FRPCM. Torque the line fitting to 18 – 22 Nm.

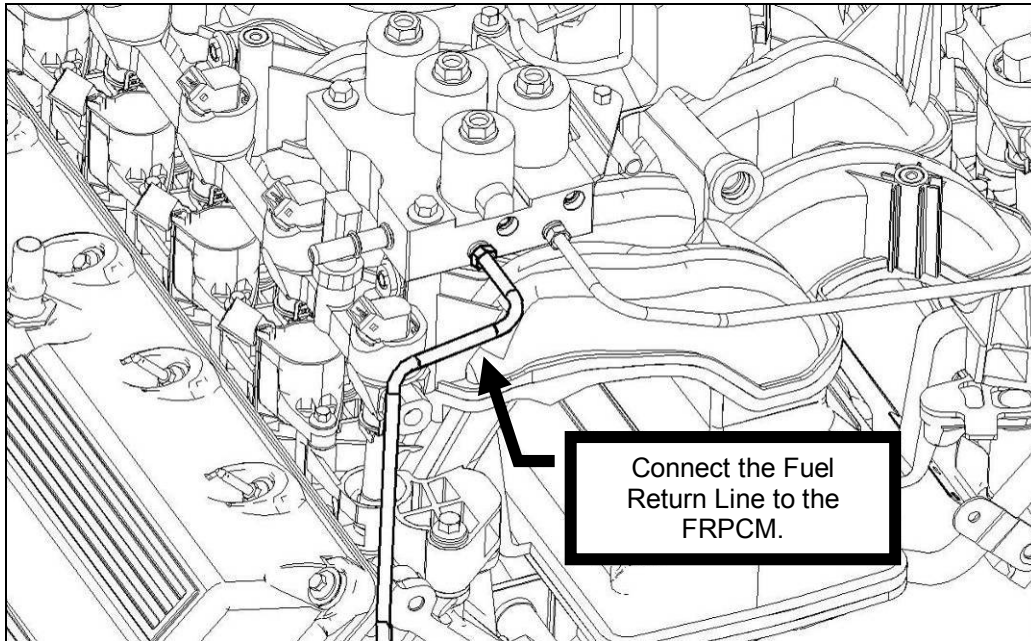

8. Install the Forward Fuel Supply Line (P10C2-9F911-AA Orange Tag) into the **TOP RIGHT PORT** on the FRPCM. Torque the line fitting to 18 – 22 Nm.

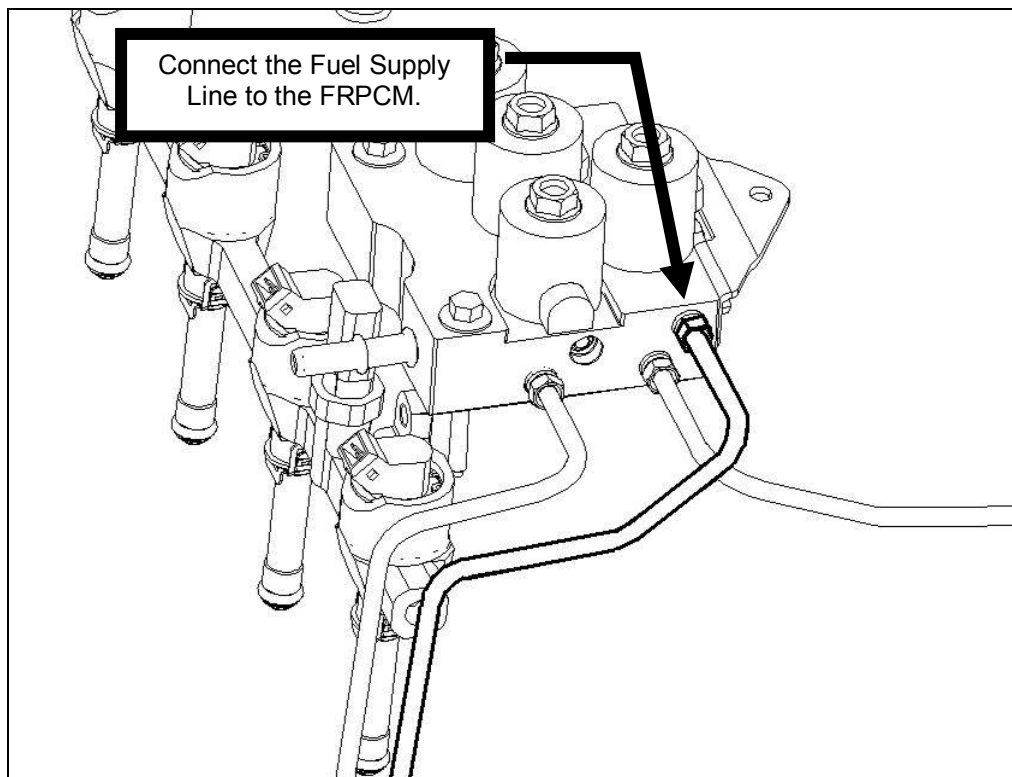

ROUSH CleanTech E-150/250/350 Liquid Propane Autogas 2010 Kit Installation Instructions

9. Install the Fuel Jumper Line - LH Fuel Rail to the FRPCM (P10C2-9E965-AA). Be sure to route this line as shown below. Torque the line fittings to 18 – 22 Nm.

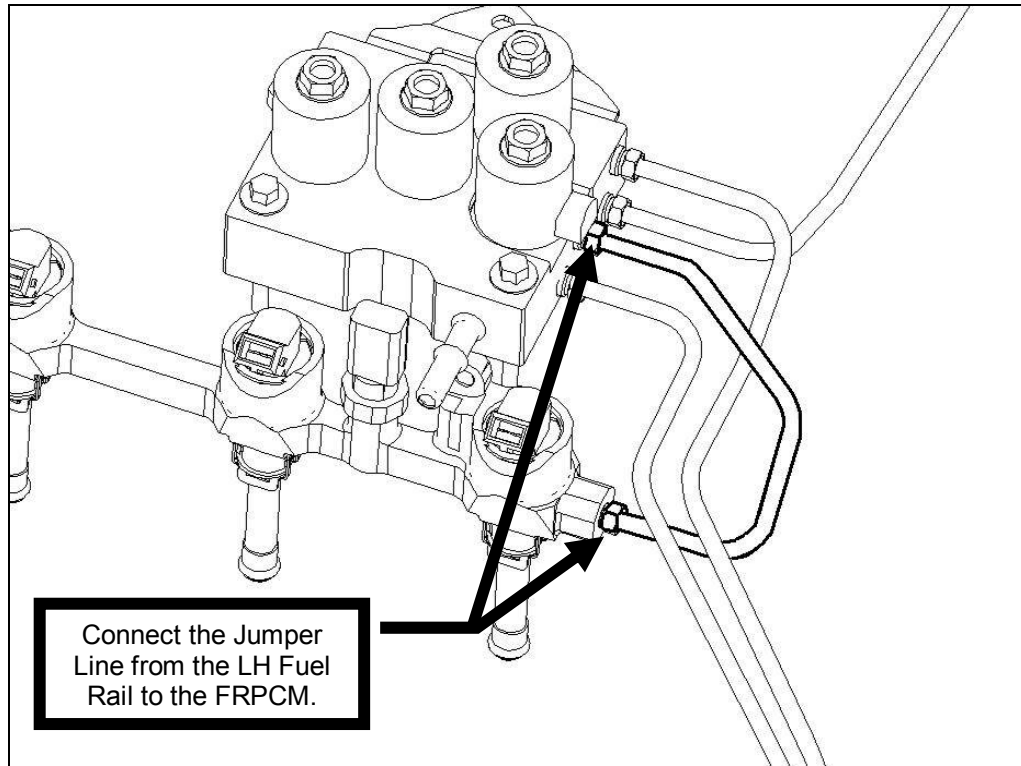

10. Connect the vapor port on the FRPCM to the vehicles vapor management system by using the FRPCM Purge Hose Assembly (P10C2-9K313-AA) provided. The female 90 degree fitting (A) connects to the FRPCM module, the straight female fitting (B) connects to the VMV valve and the male fitting (C) connects to the factory VMV hose.

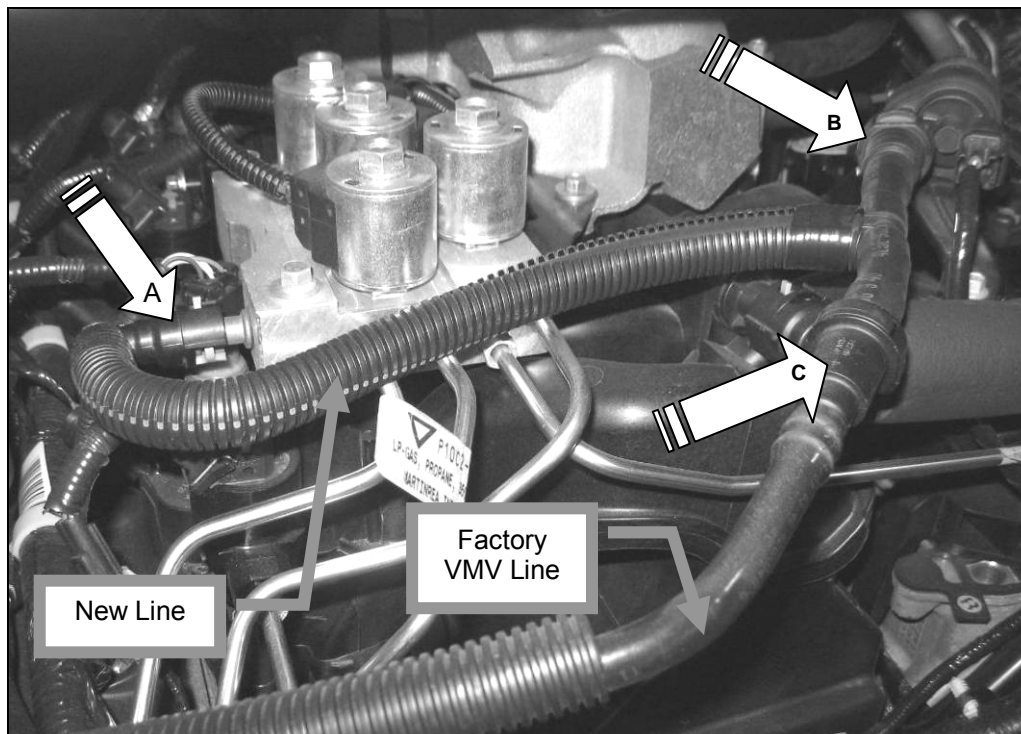

ROUSH CleanTech E-150/250/350 Liquid Propane Autogas 2010 Kit Installation Instructions

- Once all four lines have been connected to the FRPCM, install one (1) "Thick" EPDM Sleeve - 1/2" (P07L3-9C328-AA) around the return fuel line in the area inside the bellhousing retention bracket. Install one (1) "Thick" EPDM Sleeve (P07L3-9C328-AA) and one (1) "Thin" EPDM Sleeve (P07L3-9C328-BA) around the fuel supply line in the area inside the bellhousing retention bracket. Once both lines, along with the 5/8" VMV line are correctly positioned as shown below, close the bracket and bend the crimp tabs to firmly secure the lines in this location. Note: In order to properly seat the return fuel line in the leftmost "slot", it is necessary to relocate the HEGO wiring connector from this bracket to one of the threaded holes located on the rear of the LH cylinder head.

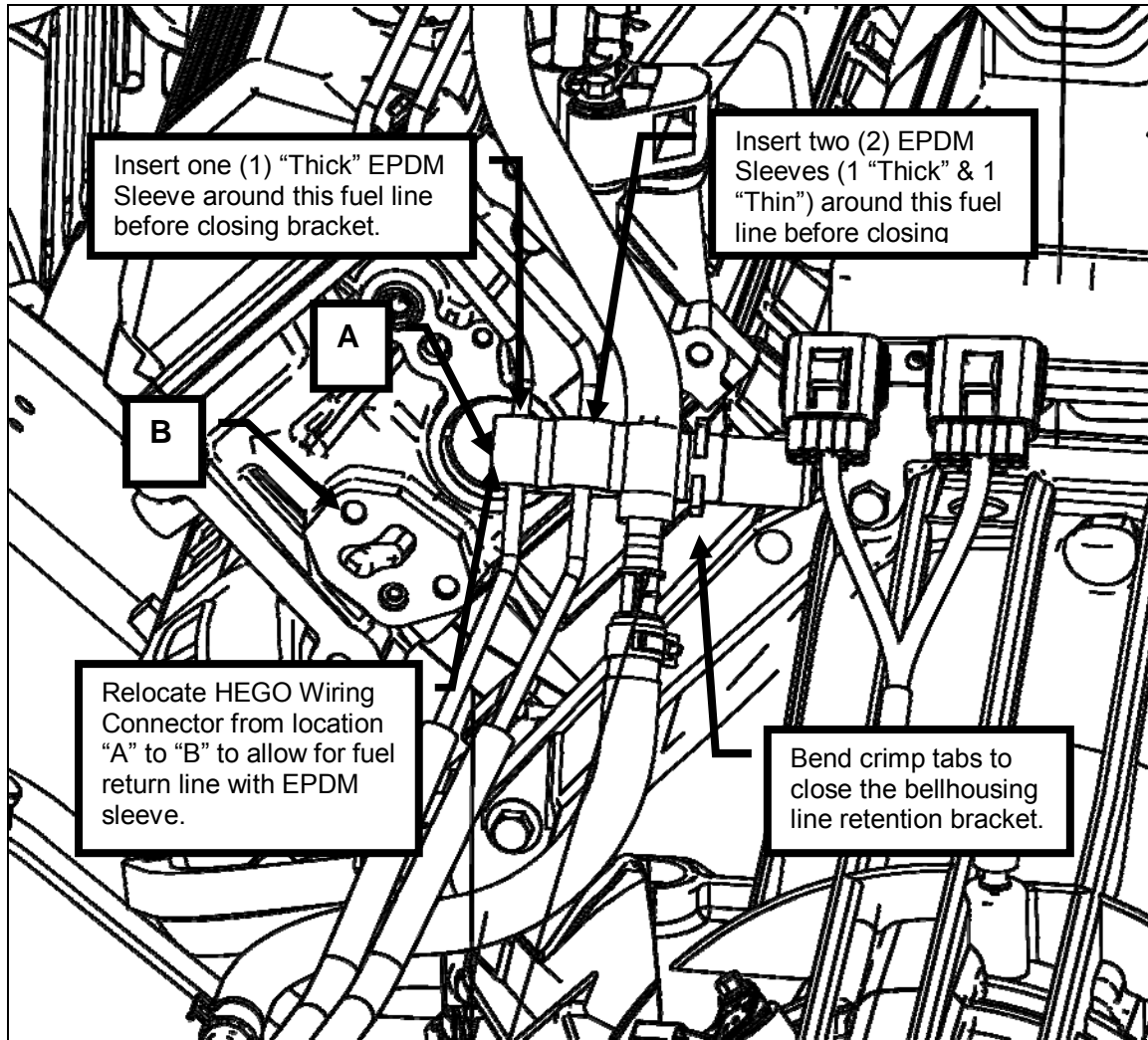

ROUSH CleanTech E-150/250/350 Liquid Propane Autogas 2010 Kit Installation Instructions

Attaching the Pressure Relief Hose and Attaching the Remote Bleeder Valve Line

1. Remove the inner fender fastener and position the pressure relief Outlet Nozzle Bracket (P10C2-9C177-BB) found in Hardware Kit E (P10C2-HKE-AA) onto the inner rear fender support as shown. Re-install the stock bolt through the van body and bracket into the nut on the inside edge of the fender. Torque the bolt to 20 -30 Nm.
2. With the pressure relief hose and the remote bleeder valve line already routed over the frame rail, attach both to the bracket. Secure the Pressure Relief Hose using one (1) Constant Tension Clamp (32150000). Install the Pressure Relief Cap (VC-985-8) onto the open port on the bottom of the bracket. Install the Remote Bleeder Valve. These parts can found in Hardware Kit E (P10C2-HKE-AA).

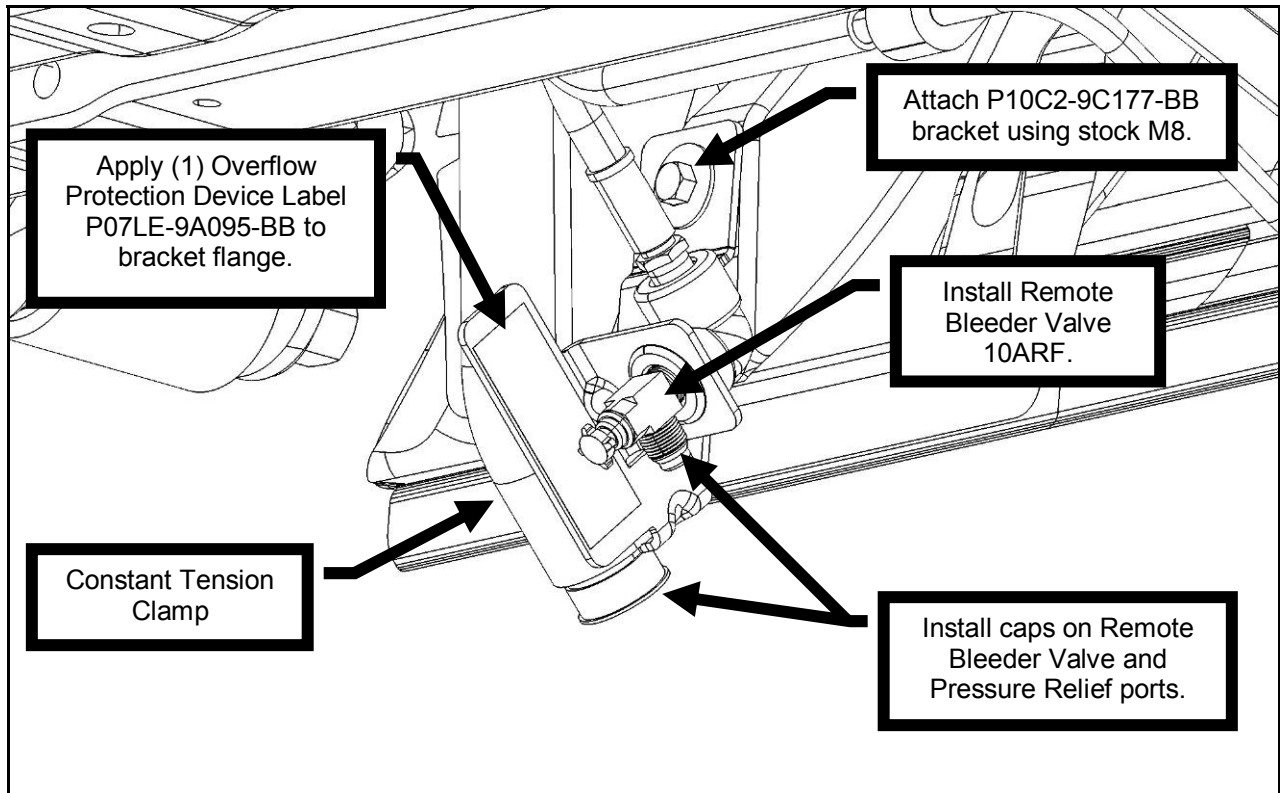

Installing the Reprogrammed PCM

1. Following the procedure described in the Ford Service Information Workshop Manual, Section 303-14, Electronic Engine Controls, install the powertrain control module (PCM).
2. Re-install the vehicle battery and connect the positive and negative terminals.

ROUSH CleanTech E-150/250/350 Liquid Propane Autogas 2010 Kit Installation Instructions

System Leak Check

⚠ Caution: — Hand tighten all fuel line connectors and fasteners before applying a wrench to avoid cross threading. Failure to heed this caution may result in property damage.

1. Verify that the remote bleeder valve (at the rear wheel well) is closed and that the bleeder valve on the tank is open.
2. Remove the cap (80001100047) from the remote bleeder valve port.
3. Attach a pressure gauge to the remote bleeder valve.

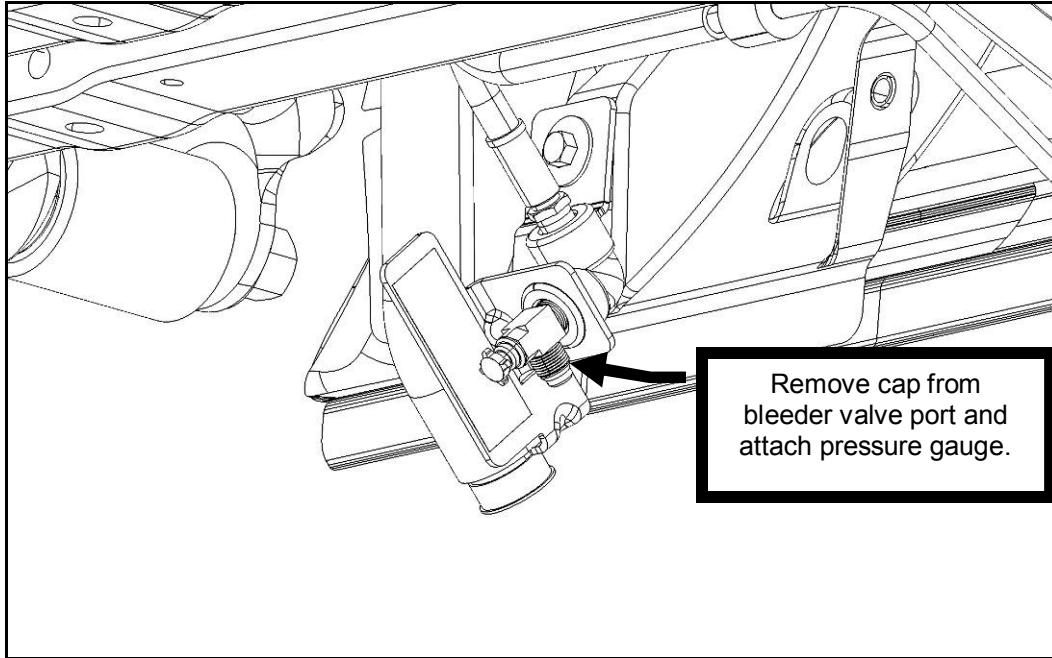

4. Open the remote bleeder valve. Pressure must exceed 90 PSI. If it does, continue to next step. If pressure does not exceed 90 PSI, contact ROUSH Technical Support at **800-597-6874** for assistance.
5. Close the valve & remove the gauge
6. Attach the fuel pressure gauge to the service port on the passenger's side fuel rail.
7. Cycle the ignition key repeatedly until the gauge reading equals the reading at the tank.
8. Allow the gauge to remain connected for a minimum of 10 minutes.
9. If the pressure degrades, search for leaks using a leak detector (i.e. soapy water, Snoop®, etc).
10. Repeat step 7, step 8 and step 9 until all leaks have been stopped and the pressure does not degrade for 10 minutes.
11. Remove the fuel pressure gauge from the service port on the fuel rail & re-install protective cap.

NOTE: If the vehicle continues to fail this test, contact ROUSH Technical Support at **800-597-6874** for assistance.

12. Open the remote bleeder valve to allow the contents of the tank to escape.
13. Close the valve.
14. Install the bleeder cap onto the remote bleeder valve.
15. Re-install the Air Induction System in the reverse order it was removed.
16. Re-install the engine cover (doghouse) inside the passenger compartment.

ROUSH CleanTech E-150/250/350 Liquid Propane Autogas 2010 Kit Installation Instructions

Installing Badges and Labels

Clean and dry all surfaces prior to applying new self-adhesive badges and labels. All labels can be found in Hardware Kit H (P10C2-HKH-AA).

1. Apply one (1) "PROPANE" Reflective Diamond Label (D-85) onto the lower right corner of the passenger side rear door.

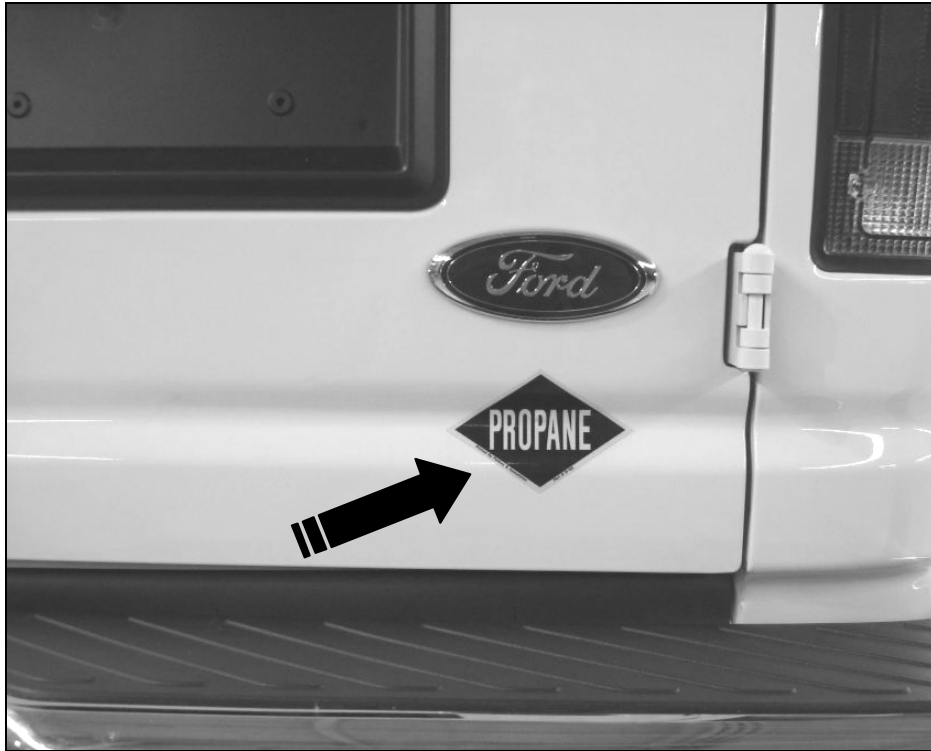

2. Apply one (1) HD-5 Propane Label (P07L3-9A095-AA) on the inside top center of the fuel door. Apply one (1) Overflow Protection Device Label (P07L3-9A095-BB) on the inside middle of the fuel door and a second one (1) on the Pressure Relief Outlet Nozzle bracket. Apply one (1) 350 PSI Working Pressure Label (P07L3-9A095-IB) on the inside bottom center of the fuel door.

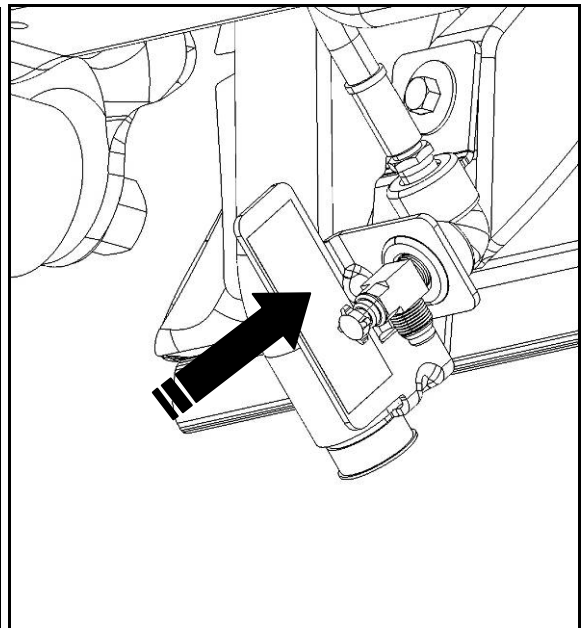
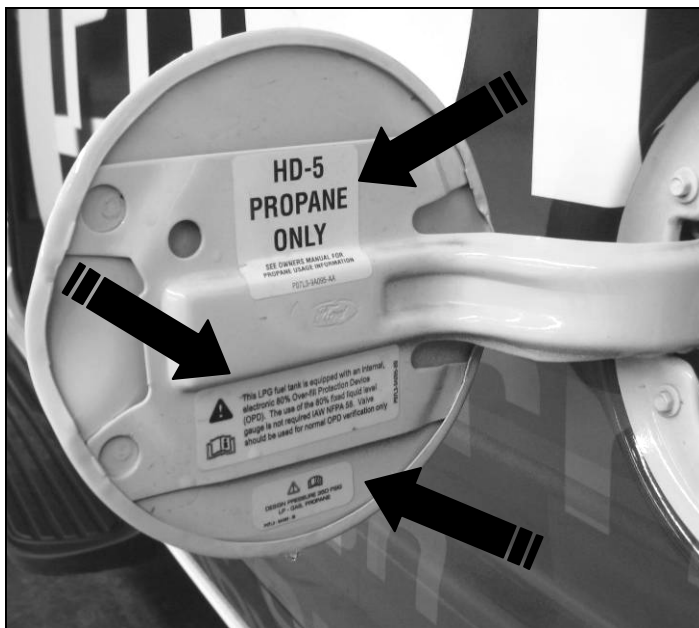

ROUSH CleanTech E-150/250/350 Liquid Propane Autogas 2010 Kit Installation Instructions

3. If not already done, remove the service port cap and install a Fuel Rail Service Port Warning Label (P07L3-9A095-DA) onto the fuel rail. Reinstall the cap.

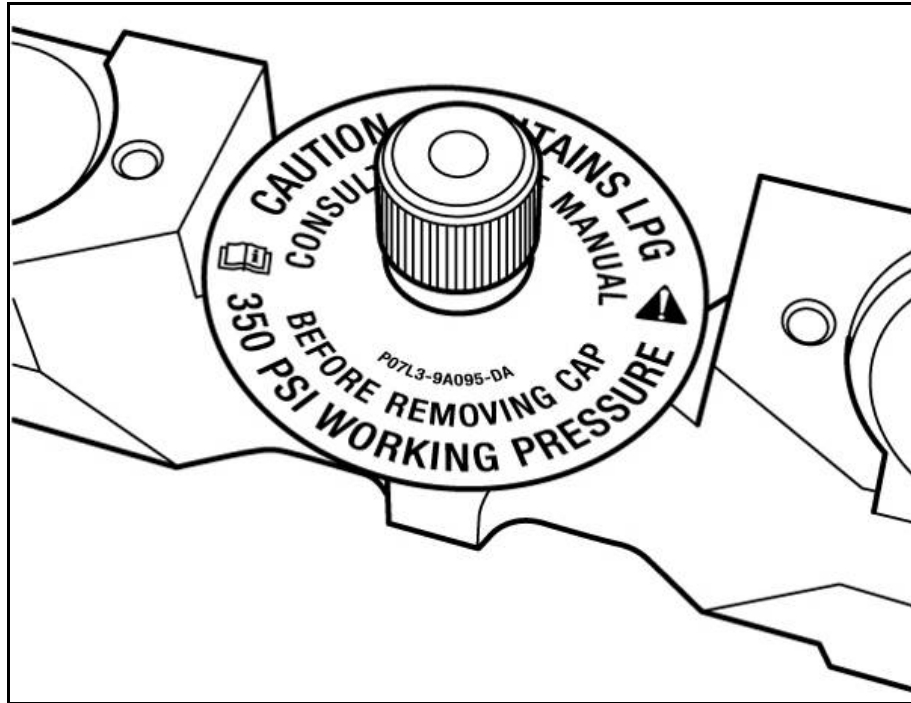

4. Apply the ROUSH VECI label to the underside of the hood on the passenger side of the vehicle to the left of the Ford label.

Note: This label is vehicle-specific and is required by law to be applied the vehicle to which it is assigned. Use the label included with the PCM when returned to you by ROUSH.

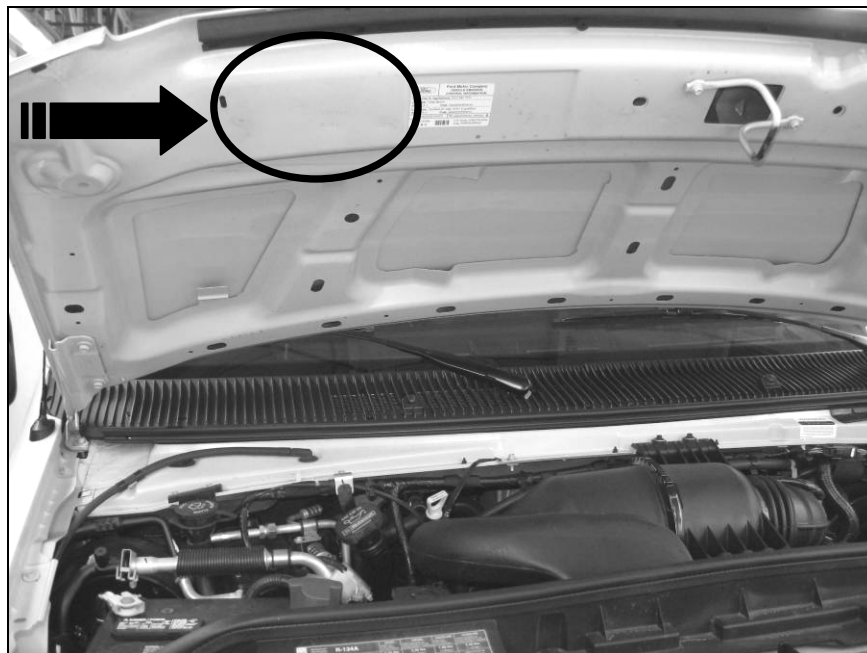

ROUSH CleanTech E-150/250/350 Liquid Propane Autogas 2010 Kit Installation Instructions

5. Apply the Bleeder Valve Inspection Label (P07L3-9A095-CA) to the side of the driver side door as shown.



6. Install the FTC Label (P10C2-9A095-AA) onto the passenger door window.
7. Install the PCM Tamper Label (R07100008-10-AA) onto the cowl below the wiper tray near the PCM.

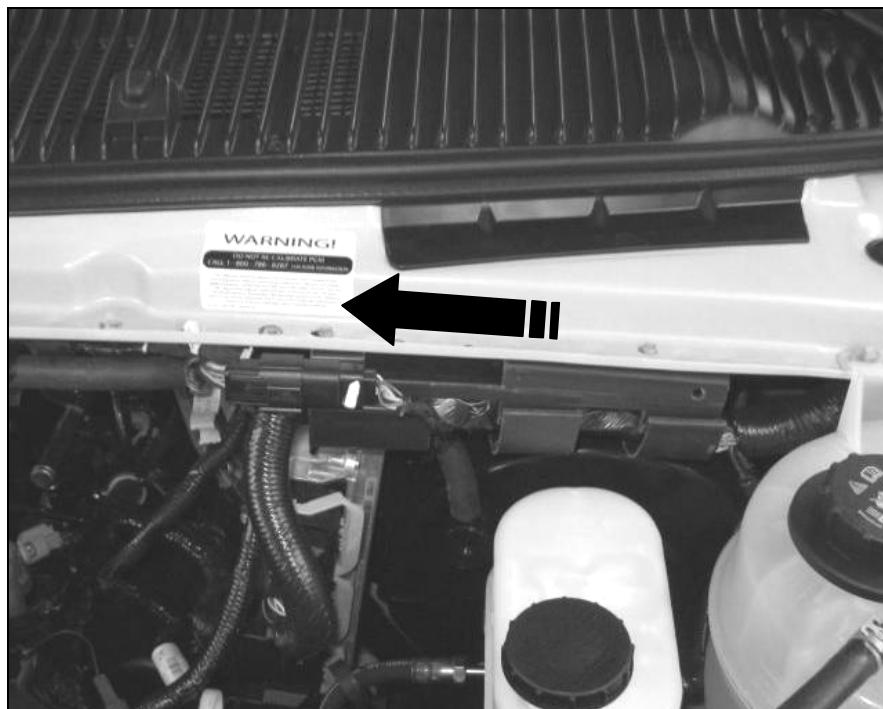

ROUSH CleanTech E-150/250/350 Liquid Propane Autogas 2010 Kit Installation Instructions

Completing the Installation

The following procedure is required in order to ensure that the fuel system is leak-free and that any residual nitrogen is removed from the system. Failure to complete this process could result in leaks, excessive tank pressure and filling problems.

1. If this has not already been done:
 - Fill the tank with 25 psi (172 kPa) of nitrogen.
 - Perform System Leak Check as covered earlier in this manual.
2. Remove the bleeder valve cap. Open the bleed valve and bleed the system until the system depressurizes.
3. Fill the tank with 0.1 (1/10) gallon of propane. Cycle the ignition key to the START position and then back to the OFF position. **Do NOT allow the engine to start during this step.**
4. Inspect and monitor for any leaks.
5. Remove the bleeder valve cap and open the bleeder valve for 10 minutes or until propane stops bleeding, whichever comes first. Close the bleeder valve and install the bleeder valve cap.
6. Fill the tank with 5 gallons of propane.

Note: The next step confirms if any leaks are present in the fuel system.

7. Perform a final leak inspection at all fuel fill and fuel line connections to ensure no leaks are present using Snoop®, or a dish soap and water mixture.
8. Perform End of Line (EOL) testing and road test the vehicle.
9. Verify that there are no concerns; then, fill the vehicle tank with propane and record the total amount, in gallons, to fill the tank.
10. Insert the Owners Manual (P10C2-19A321-AA) into the glove box.

IF YOU HAVE ANY QUESTIONS WITH THE INSTALLATION OF THIS KIT PLEASE CALL 1-800-59-ROUSH.

Tool List

Tool Description	Tool Number / Specification
Drill Bits	10 mm to 14 mm
Hole Saw	29 mm
Air Saw (for transmission dipstick tube bracket modification)	—

ROUSH CleanTech E-150/250/350 Liquid Propane Autogas
2010 Kit Installation Instructions

Schematics and Diagrams

