

Overview

The introduction of the Propane powered Blue Bird Vision marks a new generation in alternative fuel powered school buses. The bus is powered by a Ford Triton 6.8L V10 engine equipped with a Liquid Propane Autogas (LPA) fuel system. Unlike the traditional propane powered vehicle that supplies propane to the engine in a vapor phase the LPA system delivers, meters and injects propane in a liquid phase into the engine.

Similar to a modern gasoline engine, the LPA system stores liquid propane in the fuel tank. Dual in-tank electric fuel pumps circulate the propane through fuel rails which supply fuel to the fuel injectors. The injectors meter and inject liquid propane into each of the original ten (10) inlet ports on the Triton engine. Fuel that is not used by the injectors will return to the fuel tank through a flow control solenoid.

The ROUSH CleanTech LPA system is fully integrated using Ford's One Touch Integrated Start (OTIS) system. When the ignition key is turned to Start and released to the On position, the LPA system runs a purge process, then the starter engages and the vehicle starts with no further action required from the operator.

Fueling a propane powered bus is noticeably different than on a conventional fueled vehicle. A propane fuel system is completely sealed and the major difference is the screw-on type fill connector used for propane. When fueling, turn connector clockwise to tighten ensuring a good seal at the fill valve. The tank is equipped with an automatic stop fill device, which only allows to tank to be filled to 80% of the overall tank volume leaving room for the fuel to expand. At the 80% fill level the dash fuel gauge will read full. The fill time is only slightly longer than refueling a diesel powered bus.

Liquid propane autogas is also called liquid (or liquefied) petroleum gas (LPG, sometimes just LP gas). A vapor at normal room temperature and atmospheric pressure, a moderate increase in pressure produces its liquid state at ambient temperatures. It vaporizes readily when released. Because the liquid contains so much more energy than the same volume of vapor, liquid propane autogas is stored and shipped under pressure.

Safety Information

The National Fire Protection Association (NFPA) publishes a code book of rules that apply to the storage, handling, transportation, and use of liquefied petroleum gas (LP-Gas or LPG). The book is known as NFPA 58. It is revised as necessary and published every other year. This code is adopted as law in virtually every political subdivision in the United States. Check with your local and state authorities for regulations applicable to liquid propane.

Appendixes In This Chapter

Appendix 1. Roush CleanTech. Blue Bird Vision Liquid Propane Autogas Service Manual covers maintenance, disassembly, and troubleshooting for the Roush CleanTech Liquid Propane Autogas (LPA) fuel system.

WARNING *Technicians working with, or around, fuel systems should be properly trained to utilize extreme care and caution at all times. Failure to exercise extreme caution and care may lead to serious accidents which can result in property damage, personal injury and/or death.*

WARNING *Blue Bird recommends thorough review and familiarization with NFPA 58 AND the Roush CleanTech Appendix 1 of this chapter. Failure to do so may lead to serious accidents which may result in property damage, personal injury and/or death. Familiarization of these publications in no way certifies a technician to perform service on a Liquid Propane Autogas System.*

LPA Fuel System Ford 6.8L

648

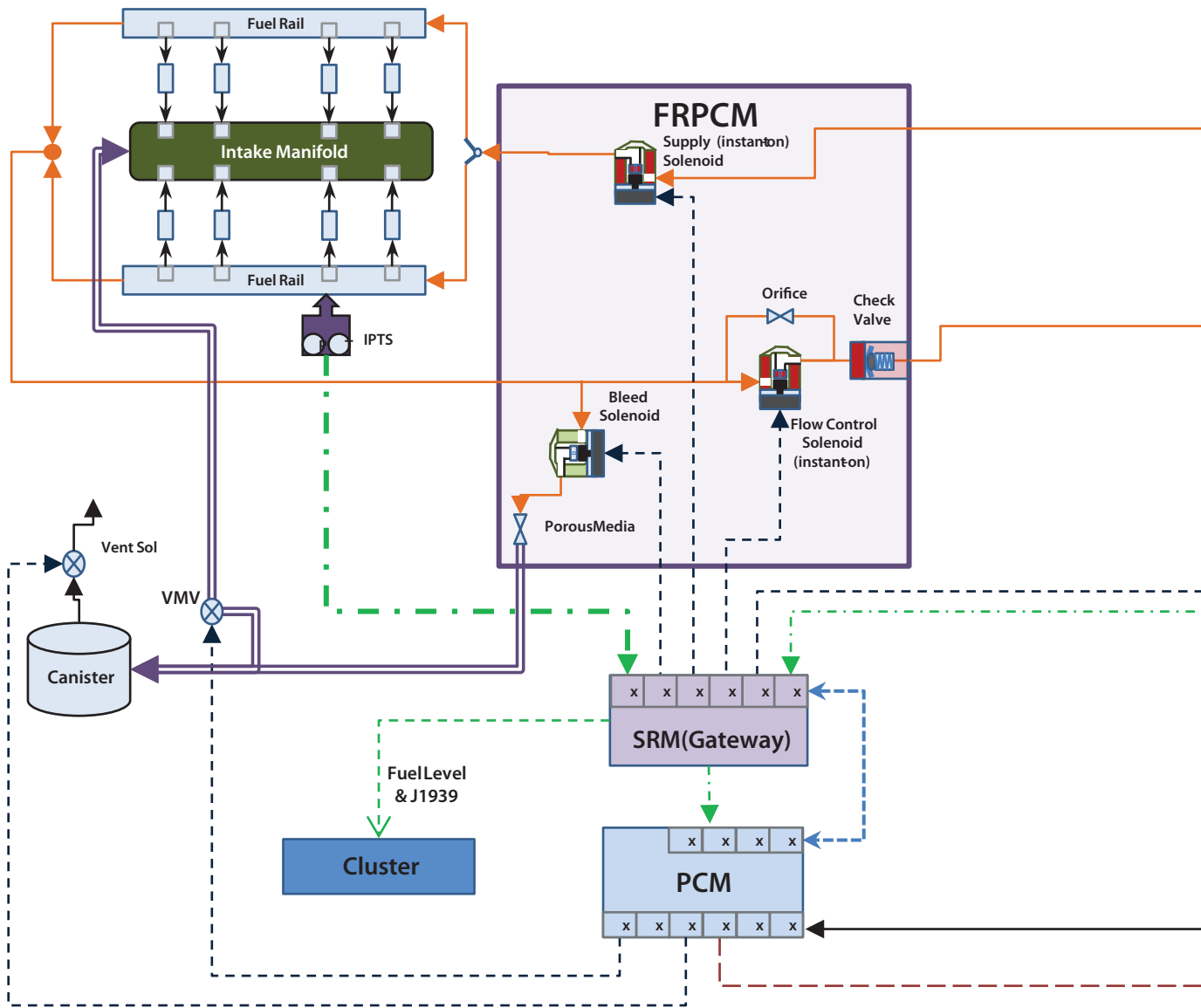

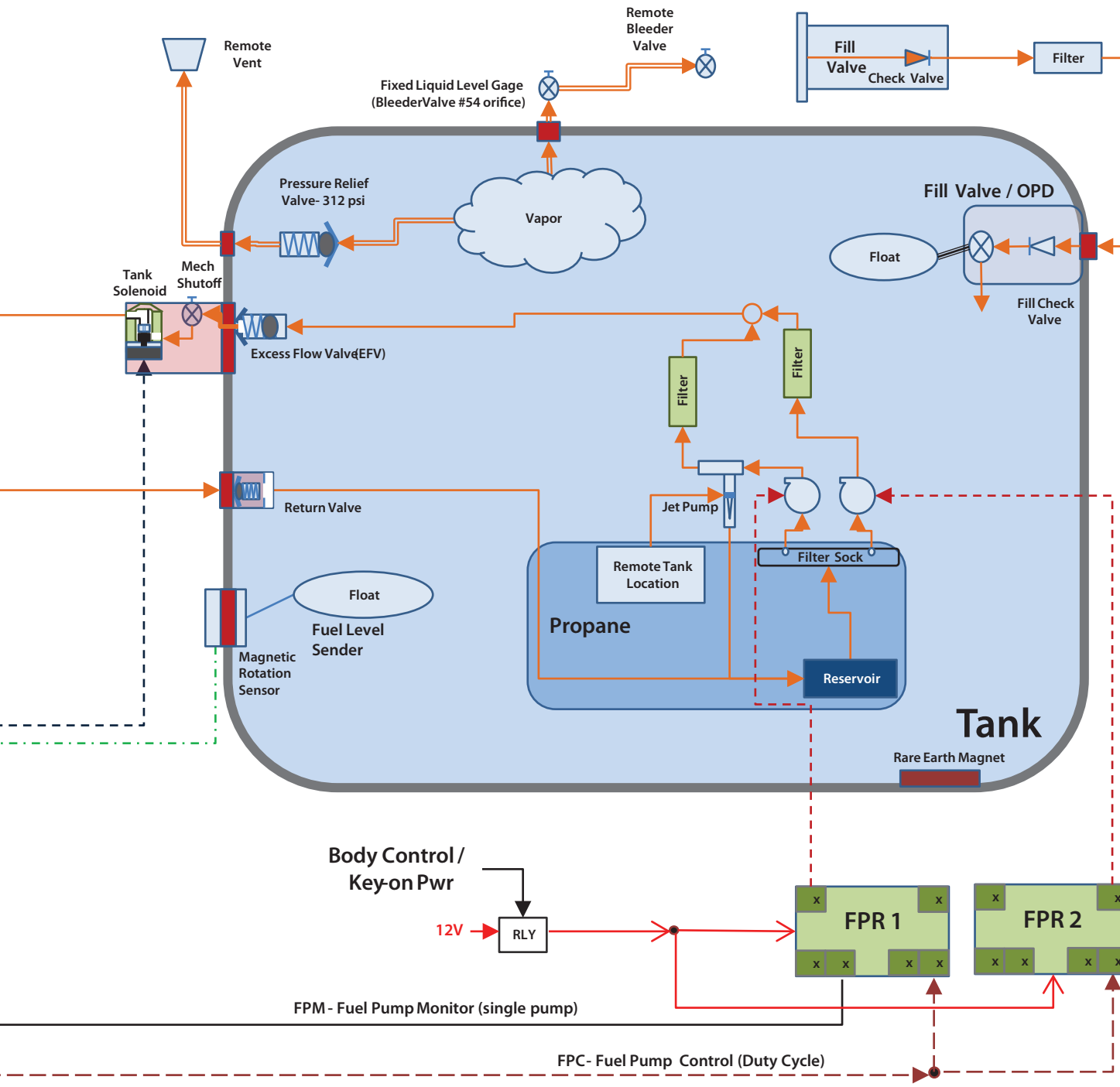

LPA Fuel System

The Ford 6.8L engine fuel supply is controlled by the same Powertrain Control Module (PCM) as used on Ford medium duty trucks; however the fuel control calibration has been optimized for propane. A Smart Relay Module (SRM) controls the fuel system solenoids, upon command from the PCM.

Electronic Fuel Pump Relays (EFPR) control the dual fuel pumps inside the tank to deliver liquid propane to the injectors. From the pumps, the fuel flows through the supply solenoid (on the tank), into the 3/8" fuel supply line, to the supply solenoid on the Fuel Rail Pressure Control Module (FRPCM), then to the fuel rails and injectors. Excess fuel flows back to the tank through the FRPCM's Flow Control Solenoid (FCS), into the 1/4" fuel return line and through the return check valve on the fuel tank. Fuel pressure is regulated by the Flow Control Solenoid (FCS) which includes a small orifice to restrict return flow in normal conditions; and a bypass circuit to allow maximum fuel flow prior to engine starting or during extremely hot conditions.

The FRPCM also contains a bleed solenoid to control the flow of fuel vapors from the fuel rail to the carbon canister during engine off conditions. The engine's Vapor Management Valve (VMV) controls the purging of the vapor canister, sending the vapors back into the intake manifold for the engine to consume.

The filling process is safeguarded against overfilling by an 80% overfill prevention device (OPD) integral to the LPA system's fuel fill valve on the tank. In order to safely store pressurized liquid propane in the vehicle, the fill system must ensure that the tank is not filled beyond 80% of its total volume. This ensures that sufficient expansion volume is present in case of significant tank temperature changes.

The LPA tank consists of dual cylinders connected by manifolds to store the liquid propane under pressure. Internal to the tank are dual electric fuel pumps, fuel pump housing, fuel filters, fuel level sender, fuel fill valve with OPD, fixed liquid level gauge, supply circuit assembly with excess flow valve, return circuit assembly and a wiring harness.

There are four (4) propane filters in the system. The primary filter is located in the fuel fill line which is intended to filter out the majority of contaminants that may be present in the fuel from the filling station. This filter must be replaced every 50,000 miles. The secondary fuel filter is a sock filter located at the bottom (inlets) of the fuel pumps. The third and fourth filters are located after each fuel pump inside the tank, which are intended to ensure that no contaminants reach the fuel injectors. The in-tank filters are rated for the life of the vehicle.

Roush CleanTech LPA vehicles require HD-5 propane, rated for automotive use. Use of HD-10 or other substandard propane may result in excess contamination of the system and failure of the fuel pump, injectors and in-tank filters.

Due to the inherent qualities of propane, a purge strategy must be employed during engine start up. Whenever the fuel pumps are not activated, there is a potential for the liquid propane in the fuel rails to absorb heat from the engine or from ambient temperatures. This heat may cause the fuel to expand rapidly and create vapor in the fuel rails. This vapor, if not purged from the fuel rails, can cause lean fueling or a no start condition. See *LPA Fuel System Ford 6.8L diagram on previous page.*

Propane Acronyms

- LPA - Liquid Propane Autogas
- LPG - Liquid Propane Gas
- PCM - Powertrain Control Module
- OTIS - One Touch Integrated Start
- SRM - Smart Relay Module
- EFPR - Electronic Fuel Pump Relay
- FP1 - Fuel Pump 1
- FP2 - Fuel Pump 2
- FPM - Fuel Pump Monitor
- FPC - Fuel Pump Control
- OPD - Overfill Prevention Device
- PRV - Pressure Relief Valve
- TS - Tank Solenoid
- SS - Supply Solenoid
- EFV/XFV - Excess Flow Valve
- FCS - Flow Control Solenoid
- FRPCM - Fuel Rail Control Module
- IPTS - Injection Pressure and Temperature Sensor
- VMV - Vapor Management Valve
- DTC - Diagnostic Trouble Codes
- CAN - Controller Area Network
- PID - Parameter ID
- WOT - Wide Open Throttle
- MAF - Mass Air Flow
- VREF - Voltage Reference
- ASME - American Society of Mechanical Engineers
- PERC - Propane Education and Research Council
- NFPA - National Fire Protection Association
- NFPA - National Fire Protection Association
- DOT - Department of Transportation



ROUSH[®]

CLEANTECH

Blue Bird Vision Liquid Propane Autogas Service Manual

651



Roush CleanTech: Appendix 1

800.59.ROUSH

ROUSHcleantech.com



Foreward.....	1	Service Preparation	18
Introduction.....	1	Alert Messages.....	18
LPA System Overview	1	Manual Fuel Shutoff	18
ROUSH CleanTech Technical Assistance	1	Opening the Manual Fuel Shutoff.....	18
Propane.....	2	Fuel Tank Pressure Relief.....	19
Fill Stations	2	Fuel System Purge, Evacuation and Priming Procedures	19
Safety Information	2	Fuel Line Purging	19
Alert Messages.....	2	Fuel Tank Draining Procedure	20
Installation, Garaging and Training	3	Using In-Tank Pumps	20
Purging and Venting (Tanks and Lines)	3	Fuel Tank Purging Procedure	22
Description and Operation.....	3	Fuel System Priming Procedure.....	22
LPA Fuel System Overview	3	Fuel System Flow Diagrams.....	23
Start Sequence.....	8	Component Servicing	26
General Propane Tank Filling Procedure.....	9	Special Tools:.....	26
Propane Powered Motor Vehicle Filling Overview	9	Quick Disconnect Tools	26
Vehicle Filling Procedure	9	Electronic Leak Detector	26
Propane Fuel Tank.....	11	Flare Tower	26
Tank Fill Valve/80% Overfill Prevention Device (OPD)	12	Fuel Tank	26
Fuel Pumps	12	Removal	27
In-Tank Fuel Filters.....	12	Replacement	28
Fuel Level Sender.....	12	Tank Fill Valve/80% Overfill Prevention Device (OPD)	29
Tank Bleeder Valve/Fixed Liquid Level Gauge....	12	Removal	29
Pressure Relief Valve	13	Replacement	29
Tank Supply Circuit Assembly	13	Tank Bleeder Valve	30
Tank Solenoid Valve	13	Removal	30
Manual Shutoff Valve	13	Replacement	30
Excess Flow Valve (XFV).....	13	Fuel Tank Pressure Relief Valve	30
Fuel Return Valve	13	Removal	30
Fuel Transfer Lines	13	Replacement	30
Fuel Rail Pressure Control Module (FRPCM)	14	Tank Supply Circuit Assembly	31
Vapor Canister Assembly	14	Removal	31
Vapor Lines.....	15	Replacement	31
Fuel Rail Assemblies	15	Removal – (Tank Solenoid Coil)	32
Remote Fill Valve.....	17	Replacement – (Tank Solenoid Coil)	32
Fill Line	17	Fuel Tank Return Valve.....	32
Fill Filter.....	17	Removal	32
Remote Bleeder Valve	17	Replacement	33
Bleeder Hose.....	17	Fuel Pump Assembly (In-Tank)	33
Electronic Fuel Pump Relay (EFPR)	17	Removal	33
LPA Smart Relay Module (SRM)	17	Replacement	33
Gateway Function.....	17	Fuel Filter and Hose Assemblies (In-Tank).....	34
LPA Interface Function	18	Removal	34



Replacement	34	Fuel Rail Pressure Control Module.....	49
Fuel Level Sender (located on top of the LH cylinder)	36	Fuel Rails and Injectors	49
Removal	36	Electrical System.....	49
Replacement	36	Torque Chart.....	50
Fuel Tank Wiring	37	FAQs.....	51
Remote Mounted Fuel Fill Valve.....	39	Special Conditions	52
Removal	39	Refueling	52
Replacement	39	Troubleshooting – Refueling	52
Remote Fuel Fill Line(s)	39	My vehicle does not fill at all:.....	52
Removal	39	My vehicle fills slowly (less than three (3) gallons/minute):.....	52
Replacement	39	My vehicle does not fill completely (shuts off early):.....	53
In-Line Fuel Filter.....	40	Troubleshooting – Starting.....	53
Removal	40	The vehicle does not start:	53
Replacement	40	The starter does not engage even after 40 seconds:.....	53
Remote Mounted Bleeder Valve	40	The vehicle does not start:	53
Removal	40	The starter engages but engine does not start or starts and will not keep running:.....	53
Replacement	40	The vehicle does start and run, but delay seems excessive:.....	54
Remote Bleeder Line.....	40	Maintenance and Specifications	54
Removal	40	ROUSH CleanTech System Use and Maintenance	54
Replacement	41	Service Recommendations	54
Fuel Rail Pressure Control Module (FRPCM)	41	Identifying ROUSH CleanTech System Components.....	54
Removal	41	Fuel Filter	54
Replacement	41	What You Should Know About Liquid Propane Autogas	54
Fuel Supply and Return Line	43	Important Safety Precautions	54
Removal (Fuel Line)	43	Refill Capacity	55
Replacement (Fuel Line)	43	Jump Starting	56
Fuel Rail	44	Manual Shutoff Valve	56
Removal	44	Storing the Vehicle	56
Replacement	44	Repainting (Vehicle or Tank)	56
Fuel Injector.....	46	DIAGNOSTIC TROUBLE CODES (DTC) — LPA-FUELED VEHICLES	57
Removal	46	Flow Control Solenoid (FCS).....	57
Replacement	46	Bleed Solenoid	57
Vapor Canister Assembly	47	Tank Supply Solenoid.....	58
Removal	47	Fuel Rail Pressure Control Module (FRPCM) Supply Solenoid and Wiring	59
Replacement	47	SRM, CAN Bus Circuit Wiring	60
Smart Relay Module	48		
Removal	48		
Replacement	48		
System Maintenance	48		
LPA Fuel System	48		
Fuel Tank	48		
Fuel Filters.....	49		
Fuel Supply and Return Line	49		



Fuel System..... 60

Heated Exhaust Gas Oxygen
(HEGO) Sensor 61

Integrated Pressure Temperature
Sensor (IPTS)..... 62

Fuel Level Sensor (FLS)..... 64

Other..... 65

**DIAGNOSTIC TESTS AND PROCEDURES —
LPA-FUELED VEHICLES** 66

General Information..... 66

No Fill 67

Slow Fill 70

Over Fill 72

Engine Does Not Crank..... 74

Engine Cranks, No Start..... 75

Engine Stumble, Stall, Rough Idle..... 77

Excess Flow Valve (XFV) Check 79

Maximum Pressure Check 79

Supply Solenoid (SS) Check 80

Fuel System Fails to Bleed 82

Fuel Pressure Drop 83

Fuel Level Indication Check..... 85

Tank Solenoid Electrical Check 85

Fuel Rail Pressure Control Module
(FRPCM) Electrical Check..... 87

Integrated Pressure Temperature Sensor
(IPTS) Electrical Check 89

Fuel Pump Electrical Test 91

Fuel Pump Control Module (FPCM)
Electrical Continuity Test..... 92

Smart Relay Module (SRM) Electrical Test 93

Fuel Level Sender (FLS) Electrical Check..... 94

**ROUSH CleanTech Blue Bird Vision Liquid Propane Autogas (LPA)
Service Manual****FOREWARD**

This manual is intended to provide technicians with the procedures required to maintain and service the unique components for the ROUSH CleanTech Liquid Propane Autogas (LPA) system. Service procedures for other vehicle components may be referenced to, which can be found in one of the Blue Bird Service Manuals. For base engine or transmission information, refer to the 2012 Ford F650 (H561) workshop manual. For access to the Ford manual, please subscribe to www.motorcraft.com.

WARNING

Technicians working with, or around, fuel systems should be properly trained to utilize extreme care and caution at all times. Failure to exercise extreme caution and care may lead to serious accidents which can result in property damage, personal injury and/or death.

INTRODUCTION**LPA System Overview**

The introduction of the Propane powered Blue Bird Vision marks a new generation in alternative fuel powered school buses. The bus is powered by a Ford Triton 6.8L V10 engine equipped with a Liquid Propane Autogas (LPA) fuel system. Unlike the traditional propane powered vehicle that supplies propane to the engine in a vapor phase the LPA system delivers, meters and injects propane in a liquid phase into the engine.

Similar to a modern gasoline engine, the LPA system stores liquid propane in the fuel tank. Dual in-tank electric fuel pumps circulate the propane through fuel rails which supply fuel to the fuel injectors. The injectors meter and inject liquid propane into each of the original ten (10) inlet ports on the Triton engine. Fuel that is not used by the injectors will return to the fuel tank through a flow control solenoid.

The ROUSH CleanTech LPA system is fully integrated using Ford's One Touch Integrated Start (OTIS) system. When the ignition key is turned to Start and released to the On position, the LPA system runs a purge process, then the starter engages and the vehicle starts with no further action required from the operator.

Fueling a propane powered bus is noticeably different than on a conventional fueled vehicle. A

propane fuel system is completely sealed and the major difference is the screw-on type fill connector used for propane. When fueling, turn connector clockwise to tighten ensuring a good seal at the fill valve. The tank is equipped with an automatic stop fill device, which only allows to tank to be filled to 80% of the overall tank volume leaving room for the fuel to expand. At the 80% fill level the dash fuel gauge will read full. The fill time is only slightly longer than refueling a diesel powered bus.

Liquid propane autogas is also called liquid (or liquefied) petroleum gas (LPG, sometimes just LP gas). A vapor at normal room temperature and atmospheric pressure, a moderate increase in pressure produces its liquid state at ambient temperatures. It vaporizes readily when released. Because the liquid contains so much more energy than the same volume of vapor, liquid propane autogas is stored and shipped under pressure.

A few liquid propane autogas facts:

- Liquid propane autogas is colorless.
- Liquid propane autogas is originally odorless. An odor is added to aid in leak detection.
- Liquid propane autogas is non-toxic, but very high concentrations in the air we breathe can asphyxiate, which can result in personal injury including death.
- Liquid propane autogas is slightly heavier than air.
- Liquid propane autogas will float on water briefly before vaporizing.
- Liquid propane autogas vaporizes rapidly and therefore is not a ground contaminate like gasoline and diesel products.

ROUSH CleanTech Technical Assistance

Technical issues involving starting, operating or re-fueling a propane power bus should be reported to your local qualified service provider. In the event further technical assistance is needed, you should first contact your authorized Blue Bird Dealer regarding any technical issues with your Blue Bird product.

In emergency situations or if immediate technical assistance is needed and the above mentioned technical assistance is unavailable you can call ROUSH CleanTech Customer Service at 800.59. ROUSH (597-6874) with any questions regarding ROUSH CleanTech Liquid Propane Autogas Systems.



Propane

Propane exists as a gas in its natural state, and like diesel fuel, gasoline or natural gas, is a member of the hydrocarbon family. Propane is a by-product of refined petroleum and natural gas. When stored under pressure, the propane turns into a liquid. Propane is colorless, odorless and non-toxic. Ethyl mercaptan is added to propane during the manufacturing process to give it a distinct, recognizable odor.

Propane is commonly referred to as LPG or LP gas. Like most liquids, liquid propane expands as its temperature increases. This is why propane tanks are only filled to 80% of its liquid capacity. Even with an 80% fill capacity, due to liquid propane's expansion ratio of 1:270 (liquid propane to a gas by volume) and its high BTU rating a large volume of energy can be stored in a relative small tank under relative low pressure.

Propane also has a very narrow range of flammability with a 2.15% threshold on the low side and a 9.6% threshold on the high side. This means that if the propane to oxygen mixture is lower than 2.15 % or higher than 9.6 % the mixture is noncombustible.

Propane is heavier than air; therefore, a leak in a propane fuel system can result in a gas accumulation in low places, such as sewers, drains or service pits. This can create a fire and health hazard as the propane will displace oxygen, potentially resulting in suffocation. For this reason, additional safety precautions should be observed when working on or around propane powered equipment or storage tanks.

Propane is stored in the vehicle fuel tank under pressure as a liquid. The pressure in the tank is determined by the temperature of the fuel, ranging from 0 psi at minus 44°F, to 312 psi at 145°F. The tank has an overpressure safety device which vents the tank at pressures over 312 psi.

ROUSH CleanTech LPA vehicles require HD-5 propane, rated for automotive use. Use of HD-10 or other substandard propane may result in excess contamination of the system and premature failure of the fuel pump, injectors and in-tank filters.

Propane, like other fuels, must be handled safely with knowledge of its characteristics. Training in propane characteristics and handling is available through the Propane Education and Research Council (PERC), 1140 Connecticut Avenue, Washington, DC 20036. Their web address is www.propanecouncil.org.

Fill Stations

Propane is readily available anywhere in the United States. To locate the nearest station, check with www.afdc.energy.gov/afdc/locator/stations.

ROUSH CleanTech recommends facilities designed for automotive refueling. Other locations may have low output pumps, resulting in slow or no fill, or low quality fuel which can result in premature component failure.



CleanTech nor Blue Bird approve of any additions to or modifications of this fuel system. This fuel system is designed and installed to meet federal standards and engine manufacturer's guidelines. The maintenance provider or modifier assumes all responsibility for the vehicle engine and fuel system if the fuel system is changed or modified. Some states require a special license to perform maintenance or work on propane powered vehicles. Check with local authorities or your state LP Gas Association for details. All fuel system components must be a minimum of 18 inches from any exhaust system component unless properly shielded. All service, maintenance and repairs performed on LP Gas systems must be done by an authorized LP Gas service technician.

SAFETY INFORMATION

The National Fire Protection Association (NFPA) publishes a code book of rules that apply to the storage, handling, transportation, and use of liquefied petroleum gas (LP-Gas or LPG). The book is known as NFPA 58. It is revised as necessary and published every other year. This code is adopted as law in virtually every political subdivision in the United States. Check with your local authorities for regulations applicable to liquid propane.

Alert Messages

The following alert messages appear from time to time in the appropriate places in this manual. Ensure that all personnel in the immediate area are aware of these reminders.



**ROUSH CleanTech Blue Bird Vision Liquid Propane Autogas (LPA)
Service Manual****⚠ DANGER**

Although propane is nontoxic, nonpoisonous, has the lowest flammability range of any alternative fuel and dissipates quickly when released into the atmosphere, propane vapor is heavier than air and seeks the lowest point. When the ratio of propane to air is between 2.2% and 9.6%, propane will burn in the presence of an ignition source at 940°F (504°C) or hotter. Keep away from heat, sparks, flames, static electricity or other sources of ignition. Failure to heed this danger may result in severe personal injury or death.

⚠ DANGER

The fuel supply lines remain pressurized after engine shutdown. Keep away from heat, sparks, flames, static electricity or other sources of ignition. Do NOT enter storage areas or confined space unless they are adequately ventilated. Failure to heed this danger may result in severe personal injury or death.

⚠ DANGER

Do NOT carry lighted smoking materials or smoke while working on fuel system components. Failure to heed this danger could result in severe personal injury or death.

⚠ DANGER

Disconnect the battery ground at the battery to ensure that the vehicle electrical system has no current. Failure to heed this danger could result in severe personal injury or death.

⚠ DANGER

Propane is heavier than air and seeks the lowest available level when released to the atmosphere. Keep heat, sparks, flames, static electricity or other sources of ignition out of the area when filling, venting or purging the fuel lines or tank. Failure to heed this danger can result in severe personal injury or property damage.

⚠ WARNING

Liquid propane is cold. The temperature of propane in its liquid state is -44°F (-42°C). Wear eye and ear protection during venting and repair operations. Keep moisture away from the valves. Failure to heed this warning can result in personal injury.

⚠ WARNING

Technicians working with, or around, fuel systems should be properly trained to utilize extreme care and caution at all times. Failure to exercise extreme caution and care may lead to serious accidents which can result in property damage, personal injury and/or death.

Installation, Garaging and Training

Chapter 11 of NFPA 58 applies to engine fuel systems using LP-Gas in internal combustion engines, including containers, container appurtenances, carburetion equipment, piping, hose and fittings and their installation. Additionally, this chapter applies to garaging of vehicles and to the training of personnel.

Paragraph 11.2 specifies that each person engaged in installing, repairing, filling or otherwise servicing an LP-Gas engine fuel system shall be trained. Contact the Propane Education and Research Council to learn more about their CETP E-Learning computer-based training program: stuart.flatow@propanecouncil.org, or vincent.sibilia@propanecouncil.org.

Purging and Venting (Tanks and Lines)

Venting of LP-Gas to the atmosphere is covered by paragraphs 7.3.1, General, and 7.3.2, Purging of NFPA 58, 2008 edition. Refer to NFPA 58, Local Codes and Proper Training for specific information relating to safe venting of LPG.

DESCRIPTION AND OPERATION**LPA Fuel System Overview**

The Ford 6.8L engine fuel supply is controlled by the same Powertrain Control Module (PCM) as used on Ford medium duty trucks; however the fuel control calibration has been optimized for propane. A Smart Relay Module (SRM) controls the fuel system solenoids, upon command from the PCM.

Electronic Fuel Pump Relays (EFPR) control the dual fuel pumps inside the tank to deliver liquid propane to the injectors. From the pumps, the fuel flows through the supply solenoid (on the tank), into the 3/8" fuel supply line, to the supply solenoid on the Fuel Rail Pressure Control Module (FRPCM), then to the fuel rails and injectors. Excess fuel flows back to the tank through the FRPCM's Flow Control Solenoid (FCS), into the 1/4" fuel return line and through the return check valve on the fuel tank. Fuel pressure is regulated



ROUSH CleanTech Blue Bird Vision Liquid Propane Autogas (LPA) Service Manual

by the Flow Control Solenoid (FCS) which includes a small orifice to restrict return flow in normal conditions; and a bypass circuit to allow maximum fuel flow prior to engine starting or during extremely hot conditions.

The FRPCM also contains a bleed solenoid to control the flow of fuel vapors from the fuel rail to the carbon canister during engine off conditions. The engine's Vapor Management Valve (VMV) controls the purging of the vapor canister, sending the vapors back into the intake manifold for the engine to consume.

The filling process is safeguarded against overfilling by an 80% overfill prevention device (OPD) integral to the LPA system's fuel fill valve on the tank. In order to safely store pressurized liquid propane in the vehicle, the fill system must ensure that the tank is not filled beyond 80% of its total volume. This ensures that sufficient expansion volume is present in case of significant tank temperature changes.

The LPA tank consists of dual cylinders connected by manifolds to store the liquid propane under pressure. Internal to the tank are dual electric fuel pumps, fuel pump housing, fuel filters, fuel level sender, fuel fill valve with OPD, fixed liquid level gauge, supply circuit assembly with excess flow valve, return circuit assembly and a wiring harness.

There are four (4) propane filters in the system. The primary filter is located in the fuel fill line which is intended to filter out the majority of contaminants that may be present in the fuel from the filling station. This filter must be replaced every 50,000 miles. The secondary fuel filter is a sock filter located at the bottom (inlets) of the fuel pumps. The third and fourth filters are located after each fuel pump inside the tank, which are intended to ensure that no contaminants reach the fuel injectors. The in-tank filters are rated for the life of the vehicle.

Roush CleanTech LPA vehicles require HD-5 propane, rated for automotive use. Use of HD-10 or other substandard propane may result in excess contamination of the system and failure of the fuel pump, injectors and in-tank filters.

Due to the inherent qualities of propane, a purge strategy must be employed during engine start up. Whenever the fuel pumps are not activated, there is a potential for the liquid propane in the fuel rails to absorb heat from the engine or from ambient temperatures. This heat may cause the fuel to expand rapidly and create vapor in the fuel rails. This vapor, if not purged from the fuel rails, can cause lean fueling or a no start condition.



**ROUSH CleanTech Blue Bird Vision Liquid Propane Autogas (LPA)
Service Manual**

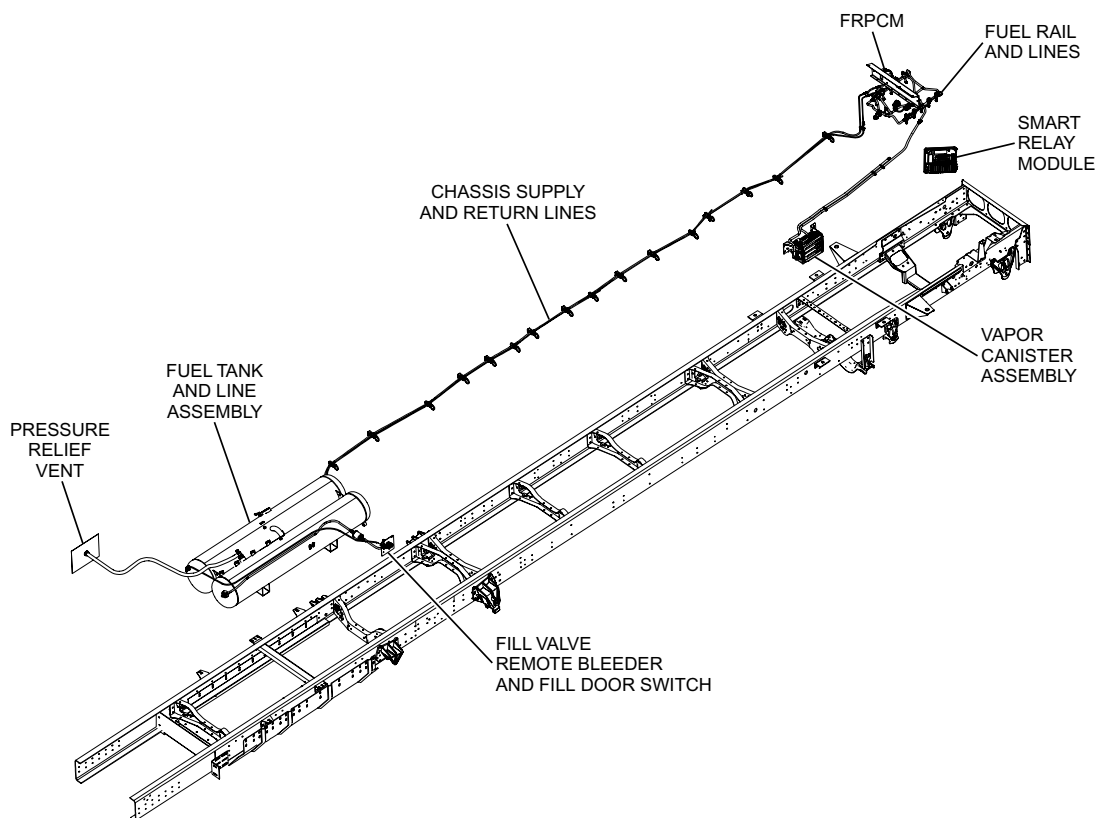

Figure 1 — Fuel and Evaporative System Overview

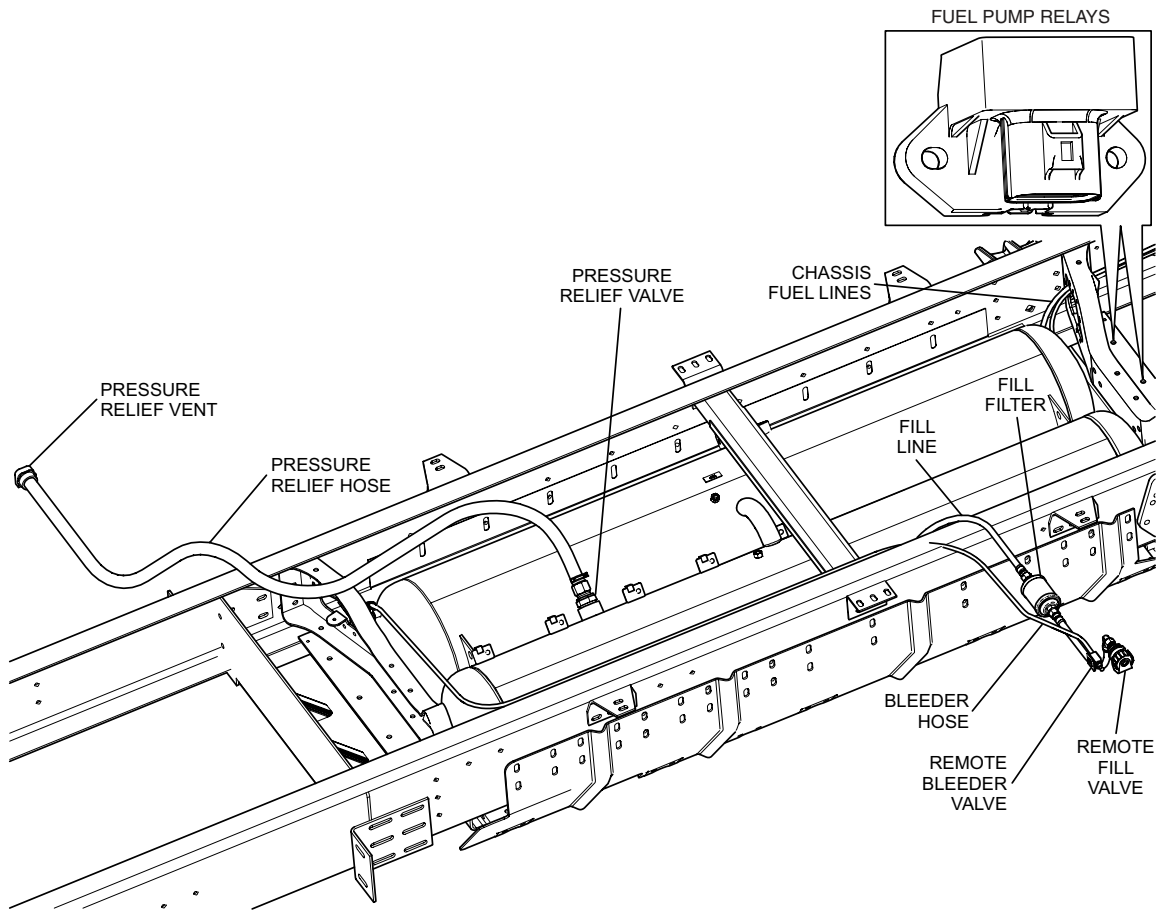

Figure 2 – Fuel Tank and Line Assembly Installed

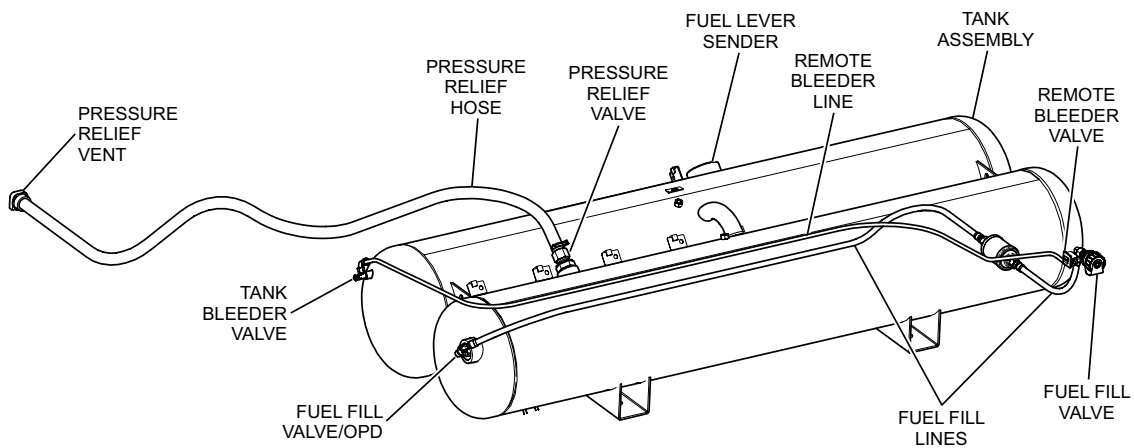

Figure 3 – Fuel Tank and Line Assembly

660



**ROUSH CleanTech Blue Bird Vision Liquid Propane Autogas (LPA)
Service Manual**

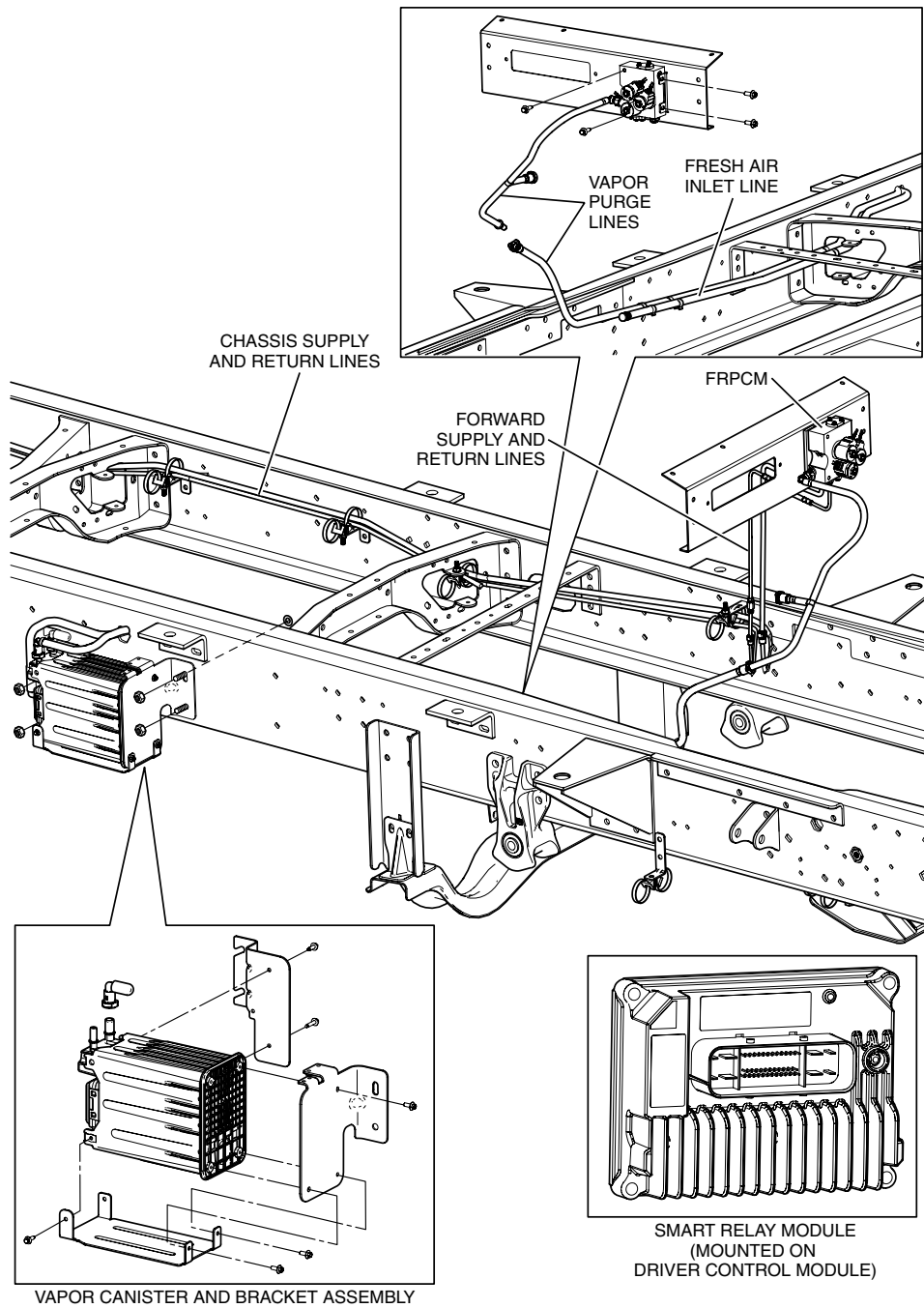

Figure 4 – Forward Fuel System Components



Start Sequence

When the engine is not running, the fuel in the rail boils and turns to vapor. For proper engine operation the vapor must be flushed from the rail prior to starting the engine. This is a fully automated process that is controlled by the PCM. This process typically takes 7-15 seconds, but depending on ambient conditions, engine off time, and engine temperature at shutdown it could take up to 43 seconds. The cycle will begin when the operator turns the key to the crank position and released to the ON position. Upon receiving the crank request, the PCM initiates the start sequence. During this time, the PCM performs diagnostics on several of the solenoids, as well as flushing the rail of vapor. This is accomplished by monitoring the Injection Pressure and Temperature Sensor (IPTS) while opening the various solenoids in the tank and FRPCM in stages, then engaging the fuel pump (see System Description for a more detail description of the components).

There are seven distinct stages of the start cycle:

Stage	Name	Description
1	CAN Bus Initialization	For the sequence to work the PCM and SRM need to be communicating. There is a short delay after key-up to ensure communication has been established.
2	Bleed Diagnostic Pressure Read	The PCM measures the fuel pressure in the rail after a bleed cycle. All solenoids are still closed at this time. If the pressure is too high, the system did not bleed and a fault will set.
3	Open Tank Solenoid	The tank solenoid is energized. The pressure in the rail is measured (again). This pressure will be used later to determine if the FRPCM supply solenoid has properly opened.
4	Open Supply Solenoid	The FRPCM Supply Solenoid is energized.
5	Flush	The FCS is energized and the fuel pump is turned on high speed. The IPTS monitors pressure and temperature in the rail to determine when the vapor has been cleared from the rail.
6	Pressure Build	The FCS is de-energized and the pressure is allowed to rise. The IPTS is still monitoring the pressure and temperature in the rail to ensure there is liquid in the rail.
7	Crank	Once the pressure has built in the rail and the IPTS verifies there is liquid in the rail, the starter is engaged.

662

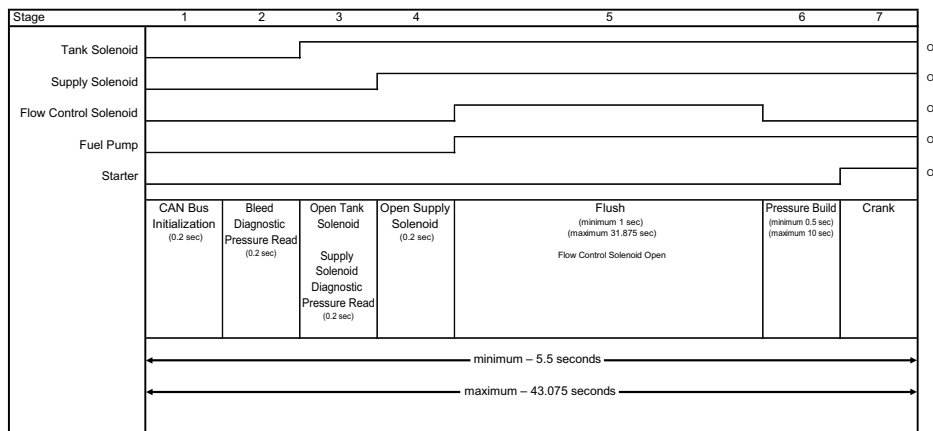

Figure 5 — Vehicle Start Sequence



**ROUSH CleanTech Blue Bird Vision Liquid Propane Autogas (LPA)
Service Manual****General Propane Tank Filling Procedure**

The most important aspect of filling a propane tank is safety. Understanding the properties and characteristics and safe handling practices of the fuel is required before conducting any propane tank filling efforts.

A propane powered vehicle is equipped with a propane tank built and certified to the regulations of the American Society of Mechanical Engineers (ASME). These tanks have a data plate with pertinent information including the ASME stamp. This plate must be securely attached and legible or the tank should be taken out of service and replaced. There are no requirements for re-certifying ASME tanks, however, inspection is required and maintenance is recommended if there are signs of corrosion.

Propane tanks are filled to 80% capacity to allow for the liquid fuel to expand and contract depending on ambient temperatures. All tanks built for use on motor vehicles are equipped with an overfilling prevention device (OPD). The National Fire Protection Association (NFPA) requires motor vehicle propane tanks be equipped with an overfill prevention device to automatically prevent filling the tank beyond the maximum recommended capacity of 80%. This automatic stop fill system prevents overfilling of the fuel tanks. This requirement has been in effect since January 1, 1984.

Propane Powered Motor Vehicle Filling Overview

The fuel fill system includes the following components:

1. Fuel fill valve, cap and mounting bracket.
 - a. The valve is located behind a locked fuel door. There is also a switch mounted to the fill valve bracket, which is activated by contacting the door.

NOTE: If the door is not closed and locked to activate the switch, the power will be cut to the engine starter, not allowing the engine to crank.

2. Fuel Fill hoses
3. Fuel Fill Filter and Mounting Clamp
4. Fuel tank mounted fill valve containing a mechanical Overfill Prevention Device (OPD).
5. Fuel Tank Internal Components

During a fill event, the system functions as follows:

1. Customer connects fuel filler nozzle to fill valve and activates the fill station pump.
2. Fuel pressure in the fill line causes the remote fill valve, tank fill valve and tank shut-off valve to open. In order for the valves to open, pressure in the fill line must be at least 20 psi higher than tank pressure, otherwise no fill is possible.
3. Once the fuel reaches the 80% fill level the overfill prevention device closes the shut-off valve, not allowing additional fuel to flow into the tank.

NOTE: Some fuel station pumps may have sufficient pressure to allow a small fuel flow into the tank even with the valves closed. The operator should stop the fill as soon the fuel flow drops noticeably.

Vehicle Filling Procedure

This filling procedure is included for reference only. All personnel conducting fills should receive safety training on proper fill procedures.

⚠ WARNING

For passenger safety, Blue Bird recommends all occupants disembark to a safety zone before fuel filling procedures take place.

1. Entering the propane fueling station.
 - a. Park the vehicle in close proximity to the motor fuel dispensing station.

⚠ WARNING

NO SMOKING ALLOWED.

2. Turn off and remove the vehicle ignition key.

⚠ WARNING

Technicians working with or around, fuel systems should be properly trained to utilize extreme care and caution at all times. Failure to exercise extreme caution and care may lead to serious accidents which can result in property damage, personal injury and/or death.

3. Exit the vehicle and ask all passengers to step outside the vehicle.
 - a. Some stations may ask all passengers to stand outside the area where the fill process is taking place.



ROUSH CleanTech Blue Bird Vision Liquid Propane Autogas (LPA) Service Manual

664

- b. Some stations could be self-service and the driver would perform the filling process; however in this case the driver has to be trained and certified to obtain an authorized filling station dispenser access card.
- 4. The attendant may need to inspect the propane tank for corrosion, dents and verify the data plate displays the ASME stamp and other pertinent information is correct. An attendant can refuse to fill your propane tank if it does not pass this inspection. Regular inspection and maintenance of your tank will prevent refusal to fill the tank.
- 5. Unlock and open the fuel door.
- 6. Verify the dispenser meter is set to zero.
 - a. If the dispenser is an electronic dispenser it will set to zero automatically once the transaction has been initiated.
- 7. Connect the fuel nozzle to the vehicle fueling receptacle.
 - a. The propane fueling nozzle has to be screwed on securely (clockwise)
 - i. Wear protective gloves while fueling a propane tank.

⚠ WARNING

Liquid propane is cold. The temperature of propane in its liquid state is -44°F (-42°C).

- ii. Remove the protective cap from the vehicle fueling receptacle.
- iii. Mate the nozzle coupling to the fueling receptacle.
- iv. Turn the nozzle coupling in a clockwise direction; two or three turns until secure. A soft rubber washer or O-ring seals the connection so over tightening is not required.
- v. Most nozzles for motor vehicle fueling are much like a gasoline type nozzle. The nozzles are also minimum bleed type for safety and to meet hydrocarbon release requirements in certain jurisdictions.

NOTE: Do not open the remote bleeder valve while filling as this will allow gaseous propane to be released.

- 8. Turn on the propane dispenser/pump and begin the filling process.
 - a. Open the nozzle to begin filling.

- b. Do not fill the tank based on a mechanical float gauge reading or the fuel level gauge on the dashboard.
- c. Pay attention and never walk away from the filling process.
- d. When the tank is full the overfill prevention device automatically stops the filling process at the 80% liquid level capacity of the tank.
- 9. Release or close the fueling nozzle.
 - a. Turn off the fuel dispenser/pump.
 - b. Carefully and slowly unscrew the fueling nozzle (counterclockwise).
 - i. A minimum bleed nozzle on the station's nozzle should have released any pressure left in the space between the nozzle and the receptacle when closed and should not bleed any pressure when unscrewing the connection.

NOTE: Some nozzles will have more pressure trapped between the nozzle and the receptacle, so it is necessary to slowly unscrew the connection to allow pressure to bleed off before removing the nozzle completely

- 10. Replace the nozzle and fuel transfer hose on the dispenser.
- 11. Verify there are no leaks at the tank filling receptacle and replace the protective cap.
- 12. The fueling process is complete.

⚠ WARNING

During a propane vehicle fueling process fuel may be emitted to the immediate area. There could be a combustible fuel mixture around this immediate area. The person performing the re-fueling process has total responsibility for safety in the immediate area.

NOTES:

- It is unlawful to fill a non-compliant tank or a tank that possesses a safety violation.
- Any person performing the re-fueling process must be trained and certified in the procedures of filling propane tanks and in the procedures of safe handling.





ROUSH CleanTech Blue Bird Vision Liquid Propane Autogas (LPA) Service Manual

Propane Fuel Tank

The LPA system utilizes a dual cylindrical manifold tank assembly to store the liquid propane. The two cylinders are permanently connected by mounting brackets and crossover tubes that create a single volume of fuel and are considered a single fuel tank assembly. The fuel tank is designed and certified to meet all applicable safety standards required for installation on a motor vehicle. The tank design includes structural mounting brackets, which are used for mounting the tank assembly between the frame rails. The tank assembly is secured to the chassis using specially coated and grade level fasteners.

In addition, the tank is fitted with a pressure relief valve (PRV) that will open if tank pressure exceeds 312 psi. The excess pressure (propane vapor) is vented off on the street side of the bus and the integrity of the tank is protected.

The following components are mounted to the outside of the fuel tank; fixed liquid level gauge (bleeder valve), supply circuit assembly, return circuit assembly, pressure relief valve, fill port check valve and fuel level sender.

The LPA fuel tank is fitted with a service port flange for accessing the internals of the tank. The following components are located inside the fuel tank; dual electric fuel pumps with an inlet filter, fuel pump outlet filters, jet pump and a wiring harness.

The tank components and their functions will be provided individually in this manual.

CAUTION

When servicing the tank or removing the tank from the vehicle be sure to reinstall the tank with the original fasteners or new like fasteners. Do not replace the fasteners with a lower grade of bolt than originally equipped as this may cause the tank to become dislodged from the vehicle and cause serious damage or injury.

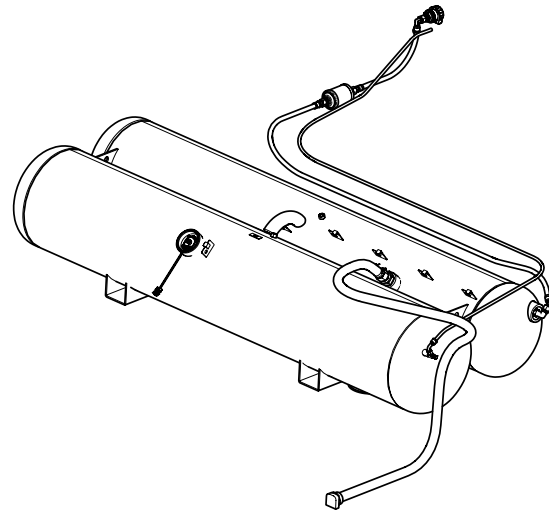

Figure 6 — Fuel Tank – Top

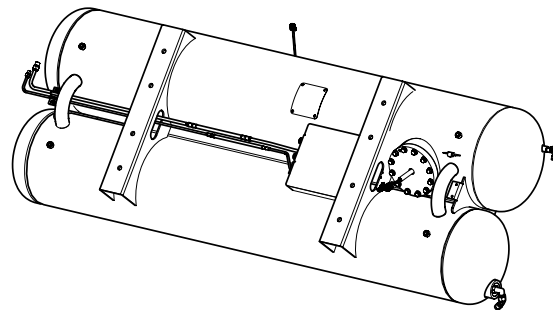

Figure 7 — Fuel Tank - Bottom



Tank Fill Valve/80% Overfill Prevention Device (OPD)

Located where fuel enters into the fuel tank, the fill valve is opened mechanically by the refueling pump pressure during the fill process. It also incorporates a back flow check valve and an overfilling prevention device. The back flow check valve closes when vehicle tank pressure is greater than pressure outside of the tank to prevent fuel from escaping.



Figure 8 — Fuel Fill Valve/Overfill Prevention Device (OPD)

Fuel Level Sender

The tank is fitted with a fuel level sender that consists of an in-tank float arm coupled to an externally mounted variable resistor. This sender provides a fuel level signal to the instrument panel, which utilizes an “anti-slosh” signal conditioner to provide a constant gauge reading. The fuel level sender is serviceable from the top of the tank and includes a visual indicator which can be referenced during service.



Figure 9 — Fuel Level Sender

Tank Bleeder Valve/Fixed Liquid Level Gauge

The bleeder valve/fixed liquid level gauge serves two functions:

1. Offers a means to evacuate the tank for tank internal component service procedures.
2. Allows annual verification of the function on the Overfill Prevention Device (OPD).

NOTE: The tank bleeder valve is to remain open during vehicle operation.



Figure 10 — Tank Bleeder Valve/Fixed Liquid Level Gauge

Fuel Pumps

The LPA fuel system utilizes two 12-volt in-tank fuel pumps. The fuel pump assembly is mounted to brackets located in the bottom of the fuel tank. The pumps and filters are serviceable through the service port opening on the bottom of the fuel tank.

The in-tank pumps receive a 12-volt supply when the ignition key is switched on and runs a purge cycle for up to 30 seconds. Each pump is controlled by an Electronic Fuel Pump Relay (EFPR), which are controlled by the PCM. The pump is provided with a constant ground signal. During operation the pump voltage will vary from 7 – 13.5V.

In-Tank Fuel Filters

There are three (3) in-tank fuel filters. The primary fuel filter is a sock filter located on the bottom of the fuel pumps at the pump inlet ports. The second and third filters are located after each fuel pump inside the tank and are intended to ensure that no contaminants reach the fuel injectors. These internal tank filters are rated for the full vehicle life and do not require scheduled maintenance.





ROUSH CleanTech Blue Bird Vision Liquid Propane Autogas (LPA) Service Manual

Pressure Relief Valve

The pressure relief valve will activate when tank pressure is above 312 psig. Propane vapor will vent through the pressure relief hose until tank pressure is between 281 – 309 psig. Propane vapor is vented out of the pressure relief hose and exits the vehicle vent mounted to the body on the street side behind the rear axle. This is a safety feature designed to prevent excessive tank pressure.

Tank Supply Circuit Assembly

The Fuel Supply Circuit consists of an Excess Flow Valve, Tank Solenoid (automatic shut off valve) and a Manual Shutoff Valve. The supply circuit Tank Solenoid is controlled by the PCM and is activated whenever power is supplied to the fuel pump.

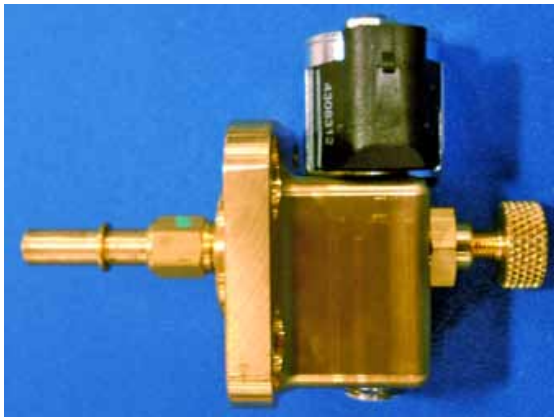

Figure 11 — Fuel Tank Supply Circuit

Tank Solenoid Valve

The tank solenoid is an electrically operated automatic shutoff valve. It is located downstream from the Excess Flow Valve and Manual Shutoff Valve. The Tank Solenoid is normally in a closed position (de-energized), preventing the flow of fuel to the engine. When the ignition key is turned on to start the vehicle, power is supplied to the solenoid opening the valve and allowing fuel to flow from the tank to the engine. The tank solenoid will close when the ignition is shut off, or if the engine stalls (with ignition on).

Manual Shutoff Valve

The Manual Shutoff Valve is used to seal the outlet of the tank during shipping, service or in case of a vehicle failure. It is located between the Excess Flow Valve and Tank Solenoid Valve. It is manually operated by turning the knurled knob mounted on the front of the Supply Circuit Assembly. Turning the knob clockwise closes the valve and turning the knob counterclockwise opens the valve. It should always be open when the vehicle is operating.

Excess Flow Valve (XFV)

The Excess Flow Valve is located in the supply fuel path, ahead of the Tank Solenoid and Manual Shutoff Valve. The valve is intended to shut off fuel flow from the tank in the event of a rapid pressure drop outside the fuel tank. A rapid pressure drop could be caused by a severed line or an inadvertent disconnect without shutting the Manual Shutoff Valve. If the excess flow valve trips (may happen after servicing the system), it can be reset by closing the manual shutoff valve and then slowly opening it. The excess flow valve does not completely stop flow and will not actuate with smaller leaks, so it should not be relied on for servicing purposes. If the excess flow valve activates (such as immediately following service where the system may not be primed with fuel), turn off the key and wait 15-30 seconds then retry.

Fuel Return Valve

The fuel return valve on the tank incorporates a check valve, which prevents fuel from flowing from the tank into the return line. The valve contains a Jiffy-Tite quick connect fitting outside the tank and an SAE hose quick connect inside the tank.

Fuel Transfer Lines

The fuel transfer lines utilized in the LPA fuel system are made of a steel-reinforced PTFE with stainless steel hard line sections to provide long term protection and service. The 3/8" supply and 1/4" return lines contain Jiffy-Tite quick connect couplings, which require special tools to disconnect.

NOTE: Special tools are required to properly disconnect the quick connect fittings. Attempting to remove the lines without these tools can cause damage to the fitting and/or line.



NOTE: When replacing hoses and lines, use Roush CleanTech replacement parts made from the same material and size. Always route and secure hoses as originally installed. All hoses and lines must be compliant and labeled per NFPA 58 requirements.



Figure 12 — Flexible Fuel Line (typical female quick connect shown)

Fuel Rail Pressure Control Module (FRPCM)

The FRPCM is a unit consisting of three (3) normally closed solenoids and a return check valve. The FRPCM is controlled directly by the Smart Relay Module (SRM) which is governed by the PCM. Included in the FRPCM are:

Supply Solenoid — Open (energized) when the engine is running, the supply solenoid allows fuel to flow from the chassis fuel lines to the fuel rail. The supply solenoid is closed when the engine is turned off, preventing fuel from flowing from the chassis fuel lines to the engine fuel rail.

NOTE: There is a second supply solenoid located at the fuel tank which prevents fuel from flowing into the chassis fuel lines when the engine is turned off.

Return Check Valve — Open when the engine is running, the return check valve allows fuel to return from the fuel rails to the chassis fuel lines. The return check valve closes when the engine is turned off, isolating the fuel return line and fuel tank and preventing fuel from backfilling the engine fuel rail.

Flow Control Solenoid (FCS) — The flow control solenoid is located in the FRPCM return flow circuit. During normal engine operation the solenoid is closed. This directs the fuel flow through a metered orifice; this results in increased pressure at the fuel rail (similar to a conventional pressure regulator). Prior to and immediately following engine start and in extremely hot fuel conditions, the FCS opens, which opens a bypass flow circuit around the metered orifice, increasing fuel flow through the rail.

Bleed Solenoid — Closed when the engine is running, the bleed solenoid seals the fuel rail from the vehicle EVAP system. After the engine is turned off for approximately one hour, the bleed solenoid opens for a calibrated length of time allowing all the fuel pressure to bleed from the fuel rail through a metered orifice and into the carbon canister. When fuel pressure is fully bled off, the solenoid closes, preventing fuel from entering the EVAP system.



Figure 13 — Fuel Rail Pressure Control Module (FRPCM)

Vapor Canister Assembly

A vapor canister is being utilized to vent the fuel vapors remaining in the fuel rail during engine shut-off to eliminate the chance of propane leaking past the fuel injectors.



Figure 14 — Vapor Canister and Line Assembly

**ROUSH CleanTech Blue Bird Vision Liquid Propane Autogas (LPA)
Service Manual****Vapor Lines**

The fuel vapor hoses are flexible with quick connect fittings, which can be easily disconnected by pinching the connector release points.

Fuel Rail Assemblies

(Refer to Figures 15, 49, & 50)

Each fuel rail assembly is mounted to the intake manifold by three brackets, and is made up of the following components:

- Five fuel injectors retained in the fuel rail by a c-clip. The injectors are connected to the main engine wiring harness. Fuel metering and injection is controlled by the engine PCM as the injectors are opened and closed by switching the ground internally in the PCM.
- Five injector spacers sealed to the fuel rail and intake manifold injector ports by O-rings and retained to the fuel rail with a retention clip.
- Two quick connect fittings at the end of the rails connect the supply and return hoses to the fuel rail assemblies.
- An Injection Pressure and Temperature Sensor (IPTS) is mounted on the left hand rail.

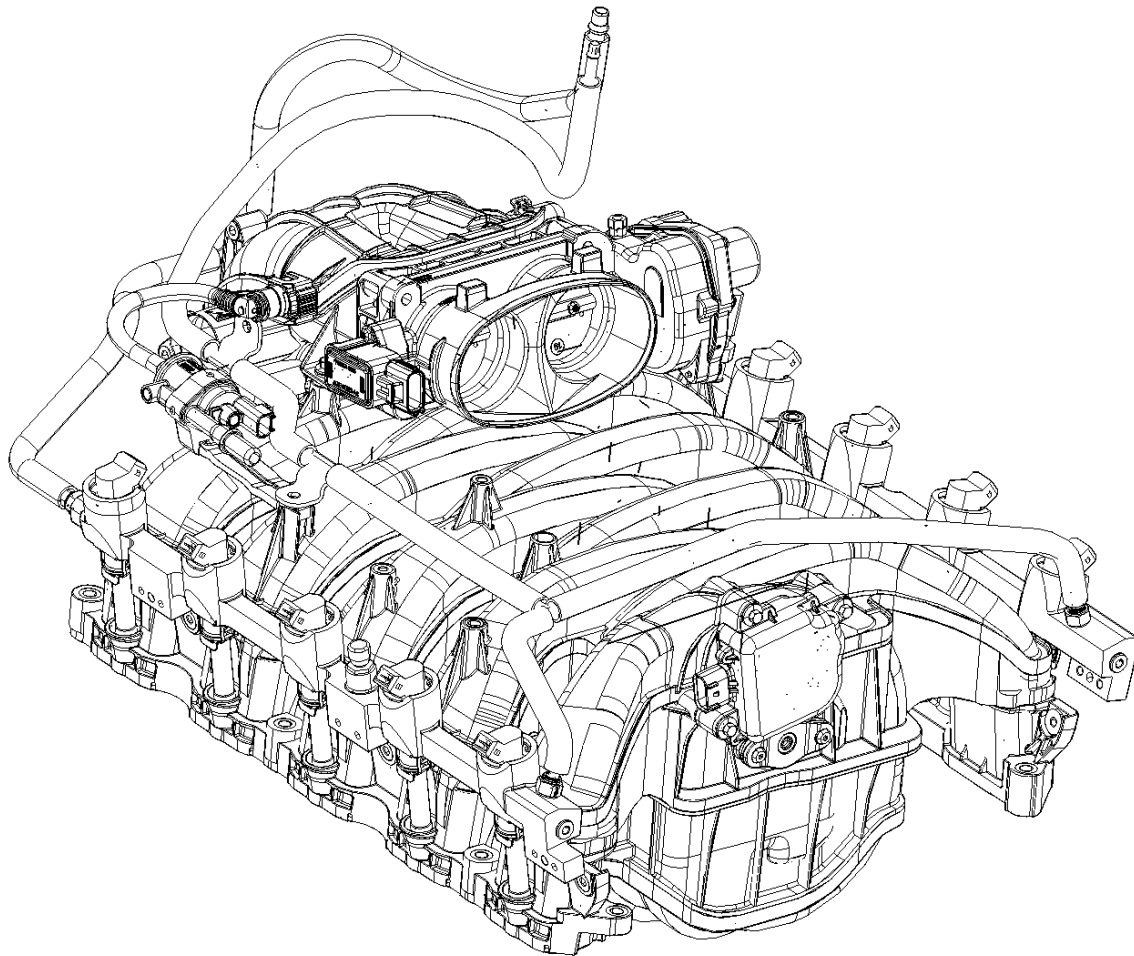

Figure 15 — Fuel Rail and Lines Installed

670



BLUE BIRD

ROUSH
 CLEANTECH

ROUSH CleanTech Blue Bird Vision Liquid Propane Autogas (LPA) Service Manual

Remote Fill Valve

This valve is used to connect the refueling station nozzle to the fill line during filling. It is mounted to a bracket behind the locked fuel door on the curb side of the bus and has a screw-on protective dust cap. It contains a backflow check valve to prevent propane in the line from escaping when the dispensing nozzle is removed.

Fill Line

The fill line is a flexible black line with non-serviceable fittings on either end, connecting between the remote fill valve, in-line fill filter and the tank fill valve.

Fill Filter

The fill filter is mounted to the bus body in-line between the remote fill valve and the tank fill valve. It consists of an internal filtering cartridge capable of filtering out contaminants as small as 5 microns. This filter should be replaced every 50,000 miles.

Remote Bleeder Valve

The remote bleeder valve is to remain closed during vehicle operation and filling.

This valve is connected to the tank bleeder valve by a bleeder hose and is used for the same functions as the tank bleeder valve.

1. Offers a means to evacuate the tank for tank internal component service procedures.
2. Allows annual verification of the function on the Overfill Prevention Device (OPD).



Figure 16 — Remote Bleeder Valve

Bleeder Hose

The bleeder hose is a flexible steel-reinforced line with non-serviceable fittings on either end, connecting the tank bleeder valve to the remote bleeder valve. This line is pressurized at all times and should only be serviced after closing the tank bleeder valve and opening the remote bleeder valve to release trapped pressure.

Electronic Fuel Pump Relay (EFPR)

The relay controls the fuel pump voltage, which controls the fuel pump duty cycle. Each fuel pump is controlled by a separate EFPR. The EFPRs are mounted to a bracket on the frame cross member in front of the fuel tank.



Figure 17 — Electronic Fuel Pump Relays

LPA Smart Relay Module (SRM)

The Smart Relay Module is an electronic control module that provides two functions within the Blue Bird bus LPA system:

1. Communications gateway between the Blue Bird Bus electrical system and the Engine/Transmission controller.
2. To provide additional input/output features required for the LPA fuel system.

Gateway Function

The SRM provides the following signals to the Blue Bird bus from the Ford engine/transmission module.

- Engine data
- Transmission data
- Start in progress
- Fuel level
- Diagnostic warning light requests



ROUSH CleanTech Blue Bird Vision Liquid Propane Autogas (LPA) Service Manual

The SRM reads the following signals from the Blue Bird bus and reports them to the engine controller.

- Front AC request
- Rear AC request
- Cruise control switch positions
- Throttle Interlock requests
- High idle speed request

LPA Interface Function

The SRM controls the following functions within the LPA system

- Fuel rail pressure control module solenoids
- Fuel tank supply solenoid

The SRM supplies the following information to the Ford engine controller

- Fuel rail pressure
- Fuel rail temperature
- Second fuel pump relay module fault status
- Fuel level

NOTE: Signals supplied to the Ford engine controller will be diagnosed by the engine controller and reported as engine P-Codes. Lack of communication between the SRM and the engine controller will also be reported by the engine controller.

SERVICE PREPARATION

Alert Messages

The following alert messages appear from time to time in appropriate places in this manual. Ensure that all personnel in the immediate area are aware of these reminders.

These messages consist of reminders of Dangers and Warnings. Other reminders may appear under the heading, Notes.



Propane is nontoxic, nonpoisonous, has the lowest flammability range of any alternative fuel and dissipates quickly when released into the atmosphere. Propane vapor is heavier than air and seeks the lowest point. When the ratio of propane to air is between 2.2% and 9.6%, propane burns in the presence of an ignition source at 940°F (504°C) or hotter. Keep away from heat, sparks, flames, static electricity or other sources of ignition.

Failure to heed this danger can result in severe personal injury.



Fuel supply lines remain pressurized after engine shutdown. Keep away from heat, sparks, flames, static electricity or other sources of ignition. Do NOT enter storage areas or confined spaces unless they are adequately ventilated. Failure to heed this danger can result in severe personal injury.



Propane is heavier than air and seeks the lowest available level when released to the atmosphere. Keep heat, sparks, flames, static electricity or other sources of ignition out of the area when venting or purging the fuel lines or tank. Failure to heed this danger can result in severe personal injury or property damage.



Liquid propane is cold. The temperature of propane in its liquid state is -44°F (-42°C). Wear eye and ear protection during venting and repair operations. Keep moisture away from the valves. Failure to heed this warning can result in personal injury.

NOTE: Identify the condition (good, stuck open, stuck closed or inoperable) of each solenoid valve prior to venting the fuel tank to ensure that the solenoid valves are not the reason for vehicle service and unnecessarily venting the tank.

Manual Fuel Shutoff

NOTE: This procedure ensures that no propane leaves the fuel tank during service activities.

1. Remove the supply circuit cover on the bottom of the tank, using the thumb screws.
2. With the cover removed locate the manual shutoff valve. Turn the knurled knob clockwise until it stops and is tightly bottomed out. The propane supply from the tank is now shutoff.

Opening the Manual Fuel Shutoff

1. After fuel system service is completed, open the manual shutoff valve on the tank by turning it counter-clockwise until it stops.
2. Follow the Fuel System Priming Procedure



**ROUSH CleanTech Blue Bird Vision Liquid Propane Autogas (LPA)
Service Manual**

3. Leak-check the fuel lines and fuel rails with an electronic leak detector or leak detection solution. Repair as necessary.
4. Install the supply circuit cover back onto the tank.
5. Start and run the engine and check for diagnostic trouble codes. Repair as necessary.

NOTE: Starting the engine for the first time after the fuel supply line has been evacuated may cause the Excess Flow Valve to close which may cause the engine to run rough or stall. If this occurs turn off the ignition and wait about 30 seconds, then re-start. This may have to be repeated multiple times until the fuel supply line comes up to pressure.

Technical issues involving starting, operating or re-fueling a propane power bus should be reported to your local qualified service provider. In the event further technical assistance is needed, you should first contact your authorized Blue Bird Dealer regarding any technical issues with your Blue Bird product.

In emergency situations or if immediate technical assistance is needed and the above mentioned technical assistance is unavailable you can call ROUSH CleanTech Customer Service at 800.59.ROUSH (597-6874) with any questions regarding ROUSH CleanTech Liquid Propane Autogas Systems.

Fuel Tank Pressure Relief

To relieve excess pressure in the tank the remote bleeder valve inside the fuel door can be used.

Fuel System Purge, Evacuation and Priming Procedures

During any fuel system maintenance or repair in which the fuel pressure must be released from the system or the system completely evacuated, use the following procedures.

⚠ WARNING

Technicians working with, or around, fuel systems should be properly trained to utilize extreme care and caution at all times. Failure to exercise extreme caution and care may lead to serious accidents which can result in property damage, personal injury and/or death.

⚠ WARNING

LPG is under pressure, wear adequate eye protection. When LPG is discharged into the atmosphere the rapid change in pressure can cause a refrigerant condition in the fuel (quick cooling) and can harm your skin or cause serious burns much like frostbite. Always wear gloves.

⚠ WARNING

When releasing the fuel pressure be sure to place the discharge point of the drain hose in a safe area free from any combustible material or ignition source. Be sure that no one is in the immediate area of the discharge hose.

⚠ DANGER

Propane is heavier than air and seeks the lowest available level when released to the atmosphere. Keep heat, sparks, flames, static electricity or other sources of ignition out of the area when venting or purging the fuel lines or tank. Failure to heed this danger can result in severe personal injury or property damage.

⚠ WARNING

Liquid propane is cold. The temperature of propane in its liquid state is -44°F (-42°C). Wear eye and ear protection during venting and repair operations. Keep moisture away from the valves. Failure to heed this warning can result in personal injury.

Fuel Line Purging

Clearing the propane out of the fuel lines (purging) is required before working on many fuel system components. Following the suggested techniques for purging the fuel lines will reduce the amount of vapor released harmlessly into the atmosphere and will produce the least risk to life and property.

1. Close the manual shut-off valve on the tank supply valve.
2. Disconnect the fuel pump electrical connectors at the frame rail on the curb-side near the fuel tank. This disconnects the power to the fuel pumps.
3. Start the engine and let it run until it stalls. This purges the supply and return fuel lines of liquid propane.
4. Turn off the ignition.
5. Slowly open the bleed plug on a fuel rail to allow the remaining fuel to bleed off.



ROUSH CleanTech Blue Bird Vision Liquid Propane Autogas (LPA) Service Manual

6. Turn key on to cycle supply solenoid, but turn off before the engine cranks.
7. Tighten bleed plug on fuel rail to 8.1–9.7 Nm.
8. Disconnect the negative battery cables from the batteries.

NOTE: There may still be a small amount of propane in the lines after running this procedure. Open the lines slowly and cautiously to bleed off any remaining propane.

⚠ WARNING

When releasing the fuel pressure be sure to keep the discharge point of the line or hose in a safe area free from any combustible material or ignition source. Be sure that no one is in the immediate area of the discharge hose.

⚠ WARNING

Liquid propane is cold. The temperature of propane in its liquid state is -44°F (-42°C). Wear eye and ear protection during venting and repair operations. Keep moisture away from the valves. Failure to heed this warning can result in personal injury.

Fuel Tank Draining Procedure

⚠ WARNING

Technicians working with or around, fuel systems should be properly trained to utilize extreme care and caution at all times. Failure to exercise extreme caution and care may lead to serious accidents which can result in property damage, personal injury and/or death

NOTE: A propane fuel tank must be empty of propane before it can be transported by a carrier. Due to the volume of fuel likely to be retained in the fuel tank, releasing the vapor to the atmosphere would be wasteful, unsafe and is an extremely slow procedure without special equipment. It is suggested that a local, certified propane handling company be engaged to purge the fuel tank and recapture the fuel as the need requires.

⚠ DANGER

Propane is nontoxic, nonpoisonous, has the lowest flammability range of any alternative fuel and dissipates quickly when released into the atmosphere. Propane vapor is heavier than air and seeks the lowest point. When the ratio of propane to air is between 2.2% and 9.6%, propane burns in

the presence of an ignition source at 940°F (504°C) or hotter. Keep away from heat, sparks, flames, static electricity or other sources of ignition. Failure to heed this danger can result in severe personal injury.

The fuel tank on an LPA fuel system utilizes an electric fuel pump to deliver fuel to the fuel injectors during normal operation. If you are shipping the tank, servicing one of the valves or to service in-tank components you must follow the procedures listed below.

⚠ DANGER

Draining the LPA tank should be performed by a trained technician only. When draining a fuel tank use all the following precautions to prevent serious bodily injury, death and/or property damage.

⚠ DANGER

Propane is heavier than air and seeks the lowest available level when released to the atmosphere. Keep heat, sparks, flames, static electricity or other sources of ignition out of the area when venting or purging the fuel lines or tank. Failure to heed this danger can result in severe personal injury or property damage.

⚠ WARNING

Liquid propane is cold. The temperature of propane in its liquid state is -44°F (-42°C). Wear eye and ear protection during venting and repair operations. Keep moisture away from the valves. Failure to heed this warning can result in personal injury.

- Wear protective eye wear, gloves and clothing
- Perform the process in a well ventilated area only
- Remove all potential ignition sources from the area
- Use only the recommended processes
- Use the proper tools
- Drain the tank on the vehicle into a tank of equivalent or larger capacity

Using In-Tank Pumps

Use of the in-tank pumps to drain the tank is an acceptable method assuming at least one of the two pumps and the supply valve are functioning normally.





BLUE BIRD

ROUSH
 CLEANTECH

**ROUSH CleanTech Blue Bird Vision Liquid Propane Autogas (LPA)
 Service Manual**

NOTE: This method will not completely drain the tank and a final process of venting the tank will still be required. In some areas it is not allowed or may not be safe to vent the fuel to the atmosphere. In this case, the fuel must be burned off.

1. Move the vehicle to a well ventilated area free of any external ignition sources.
2. Place the tank in which the fuel is to be captured close to the tank to be drained.
3. Purge the fuel lines by using the Fuel Line Purge Procedure.
4. Disconnect the 3/8" chassis supply fuel line from the hard line on the tank using the appropriate disconnect tool.
5. Connect the fuel transfer hose to the receiving tank fill valve or other appropriate valve.
6. Connect the transfer hose to the vehicle tank's supply line
7. Disconnect the fuel pump wire harness in vehicle and connect a switch to the fuel pump wire connectors.
8. Open the manual supply valve on the tank to be drained.
9. Open the automatic supply valve on the tank to be drained, this requires 12V power to the supply solenoid.
10. Turn the switch on the jumper harness to the ON position, you should hear the pumps in the fuel tank running and fuel will begin to transfer to the capture fuel tank.
11. When the liquid propane level in the fuel tank drops below the fuel pumps pickup tube the pump will make a different sound. Turn the switch off to stop the pump.
12. The remaining fuel in the tank will now need to be evacuated through the bleed valve.
13. Manually close the supply valve on the vehicle tank.
14. Loosen the fuel transfer hose and bleed off the fuel pressure.

⚠ WARNING

Fuel may be under pressure in the transfer line; use caution when disconnecting the fittings, slowly loosen the fittings and use gloves and protective eye wear.

15. Disconnect the transfer hose from the receiving tank and place the other end of the transfer hose in a safe, well ventilated location away from any area where the fuel could create a volatile condition.
16. Slowly open the manual supply valve and allow the tank to vent until the pressure has been released completely from the tank. Most supply valves are rated to pass 2.3 to 3.3 gallons per minute before the excess flow rating is exceeded and could close. If the excess flow closes during this operation simply close the supply valve and re-open it slowly.

NOTE: The tank can be evacuated using a flare stand, if the service center is equipped with a stand and has received the proper training.

17. If using a flare stand to burn off the remaining fuel in the tank this would require approximately a 50 foot clearance from the vehicle, other vehicles, a building or any combustible materials. Slowly open the valve on the flare stand and light the escaping gas; open the valve little by little to decrease the time to evacuate.

⚠ CAUTION

Some states and municipalities may have regulations preventing the release of LPG into the atmosphere. Check with your local fire marshal or your local LPG supplier prior to venting or burning off a tank.

18. When the pressure in the tank has reduced to a point that it does not support the flame turn the liquid supply valve off and disconnect the hoses. Open the remote bleeder valve to vent the remaining pressure to the atmosphere.

⚠ WARNING

Do not have any sources of ignition within a minimum of 50 foot of the area.

19. Once the tank has vented, close the supply valve and bleeder valves on the tank.

NOTE: If you have any questions or concerns or you feel unqualified to perform the process of venting the tank contact your local fuel system provider or Roush CleanTech (800) 59-Roush



Fuel Tank Purging Procedure

The following procedure is required to purge the air from the fuel tank after servicing.

1. Fill the tank with 0.3 (3/10) gallon of propane and cycle the ignition key to the crank position and then to the off position. (Do not allow the vehicle to start during this step.)
2. Inspect and monitor the tank for any leaks.
3. Open the bleeder valve for 20 minutes or until propane stops bleeding, whichever comes first. Close the bleeder valve.
4. Fill with 10+ gallons of propane.

NOTE: When filling an empty tank start filling at a slow rate to build up pressure inside the tank. An initial fast fill may trip the OPD, creating a slow or no fill condition.

5. Perform a final leak inspection at all fuel fill and fuel line connections to ensure no leaks are present using an electronic leak detector or leak detection solution.
6. Install supply circuit cover on tank and hand tighten the thumb screws.

Fuel System Priming Procedure

After performing any fuel system service work air will have entered the system through the open connections and ports. You will need to prime the fuel system to expel all the air from the fuel lines and rails. To prime the fuel system turn the ignition key to the Key On Engine Off (KOEO) position, NOT THE START POSITION.

See Fuel System Description and Operation at the beginning of this chapter for detailed operation of the purge cycle.

1. Make sure the battery is connected.
2. Check to make sure there is fuel in the tank.
3. Turn the key to the KOEO position for 30 seconds.
4. Turn the key off and repeat steps 3 and 4 multiple times.
5. Turn the key to the start position. When the "Start In Progress" light goes out the engine will automatically crank to start.

NOTE: If the engine fails to start refer to the *Fuel System Pressure Check Procedure* in this manual.



**ROUSH CleanTech Blue Bird Vision Liquid Propane Autogas (LPA)
Service Manual**

Fuel System Flow Diagrams

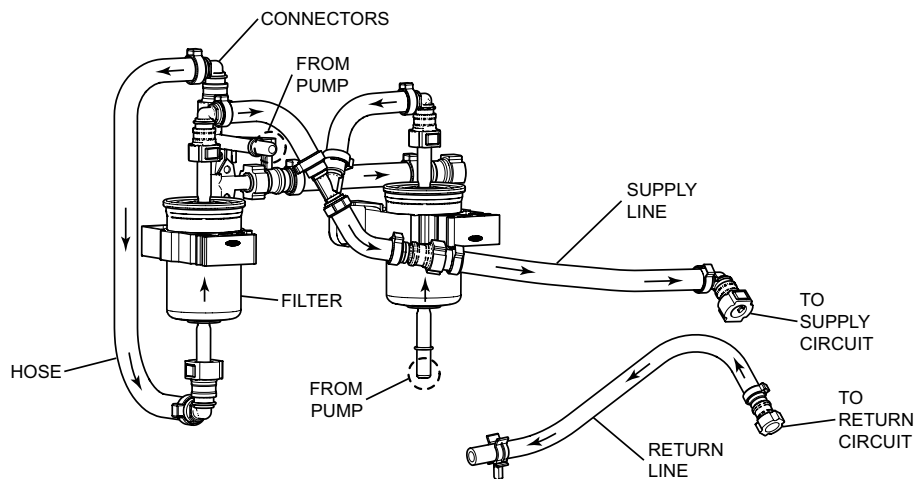

Figure 18 – In-Tank Lines and Filters

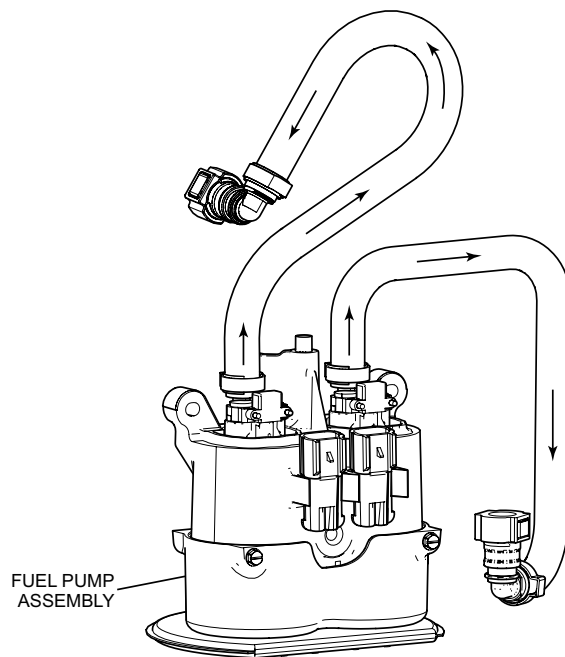

Figure 19 – Fuel Pump and Filter Assembly



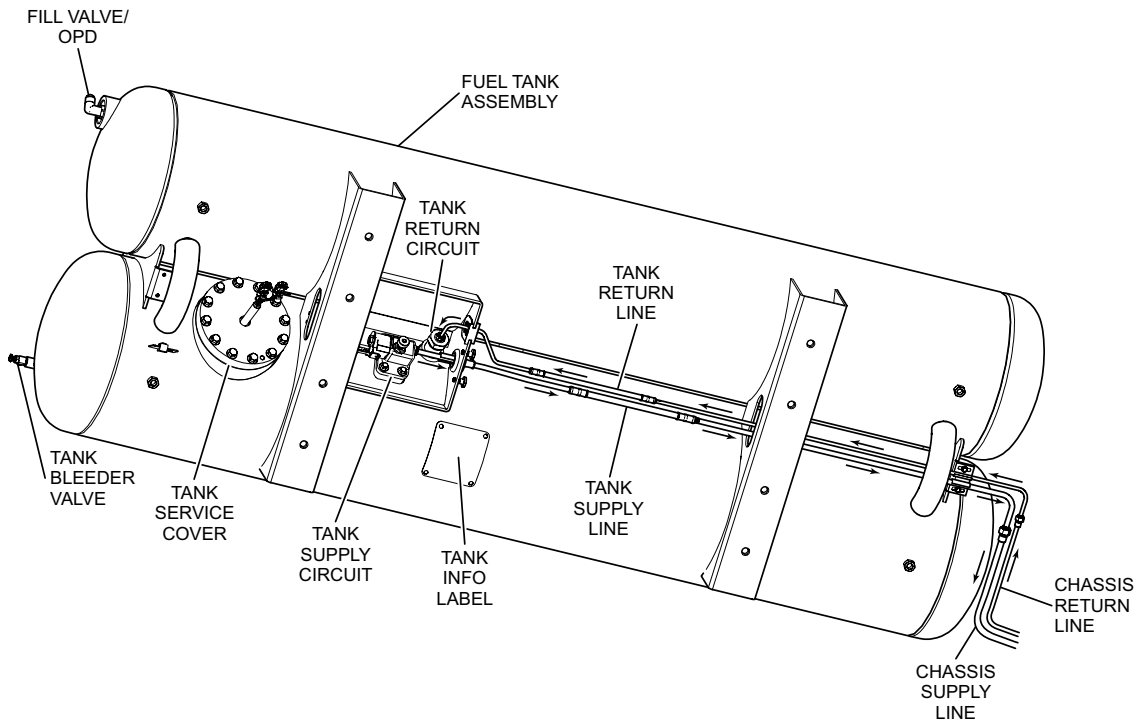

Figure 20 – Fuel Tank Bottom View

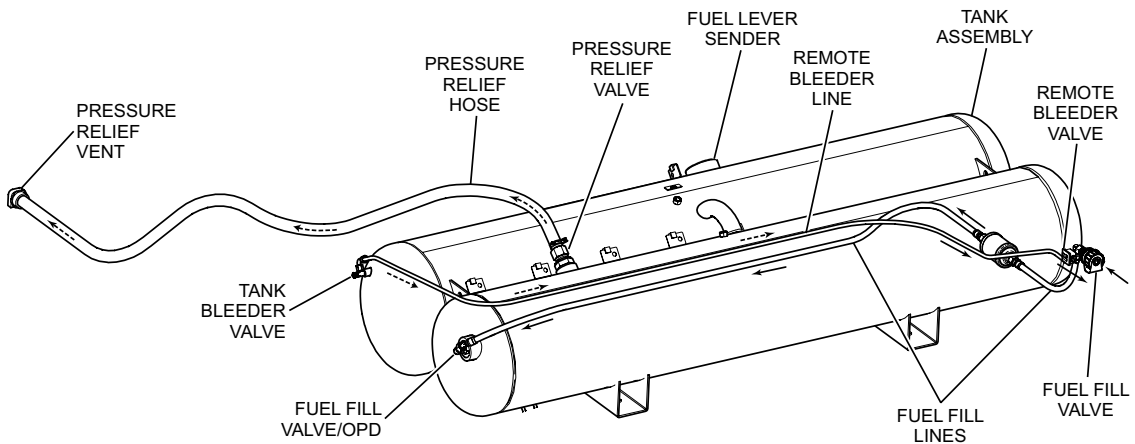

Figure 21 – Fuel System Remote Valves and Lines

678



**ROUSH CleanTech Blue Bird Vision Liquid Propane Autogas (LPA)
Service Manual**

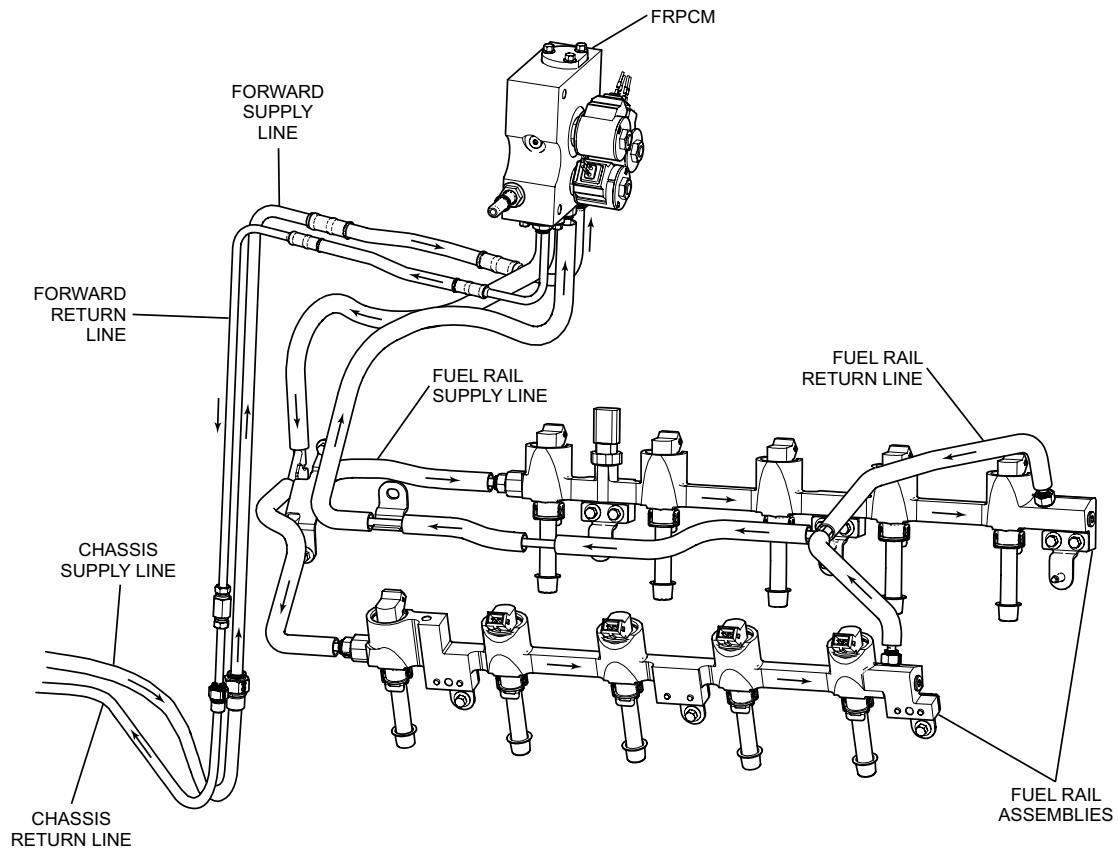

Figure 22 – Fuel Rail and Lines

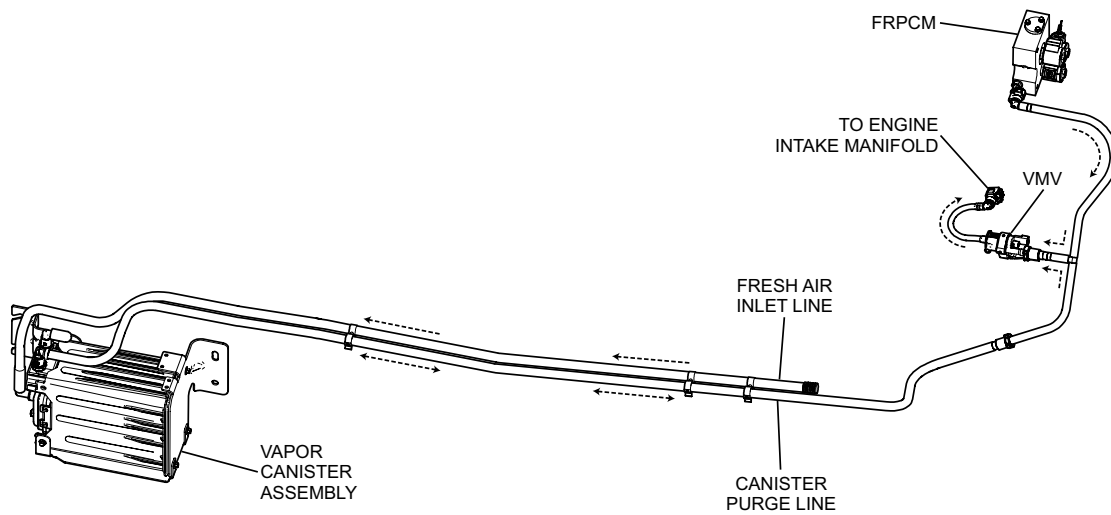

Figure 23 – Fuel Evaporative System



COMPONENT SERVICING

Special Tools:

Quick Disconnect Tools

The fuel lines in the LPA system use quick connect fittings, which require special tools to disconnect the lines. The supply lines use the 3/8" tool (JT38LP) and the return lines use the 1/4" tool (JT14DT). These tools can be purchased from:



Figure 24 – Quick Disconnect Tools

Allegany Tool Company

255 Rochester Street
Unit #14
Salamanca, NY 14779
Phone: (716) 945-0354
Fax: (716) 945-0114
www.snyder-mfg.com

Electronic Leak Detector

If purchasing an electronic leak detector, it is recommended to use a tester capable of detecting down to 35 PPM of propane vapor.

Flare Tower

A flare stand/tower can be used to burn off vented propane during servicing. If using a flare tower we recommend purchasing one from a reputable supplier, such as:

www.flameengineering.com/Propane_Flare.htm

WARNING

Do not attempt to build your own flare tower. Failure to exercise extreme caution and care may lead to serious accidents which can result in property damage, personal injury and/or death.

CAUTION

Some states and municipalities may have regulations preventing the release of LPG into the atmosphere. Check with your local fire marshal or your local LPG supplier prior to venting or burning off a tank.

Fuel Tank

The cylindrical tank assembly for the LPA fuel system is mounted in the rear overhang between the frame rails parallel to the vehicle frame.

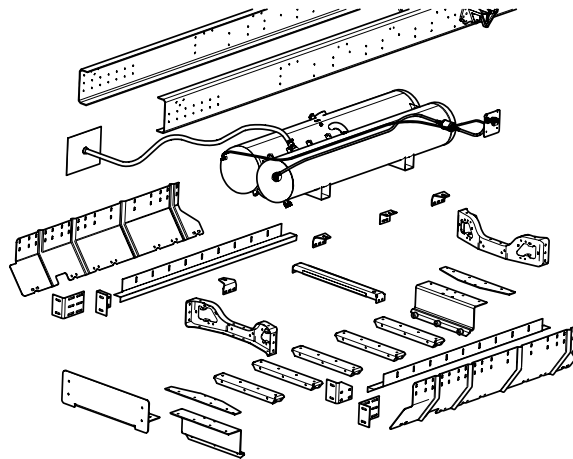

Figure 25 – Fuel Tank and Frame Supports

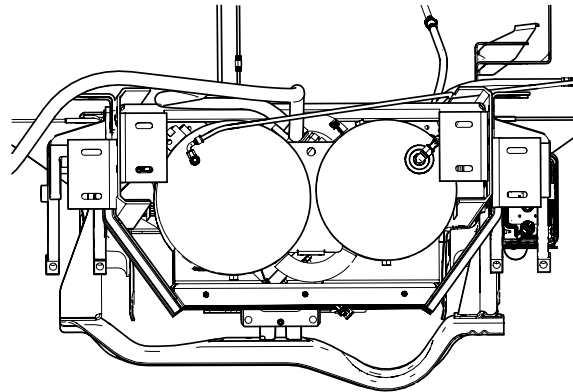

Figure 26 – Fuel Tank Installed – Rear View



BLUE BIRD

ROUSH
 CLEANTECH

**ROUSH CleanTech Blue Bird Vision Liquid Propane Autogas (LPA)
 Service Manual**

NOTE: To service the tank or any valves, make sure the vehicle is in a well ventilated area and ensure the tank is in a stable position prior to starting work.

WARNING

Technicians working with, or around, fuel systems should be properly trained to utilize extreme care and caution at all times. Failure to exercise extreme caution and care may lead to serious accidents which can result in property damage, personal injury and/or death.

WARNING

LPG Propane Gas is flammable. DO NOT vent propane in an enclosed area, or close to service pits, drainage ditches or low lying areas. DO NOT vent propane within 25 feet of any source of ignition, spark, open flame or heat. When venting propane liquid, it will vaporize at a very cold temperature (-44 F). Always wear safety goggles and gloves when handling systems venting gas. Always perform a complete system leak test after completing any service or maintenance.

CAUTION

Be sure the tank has been completely drained before removing any valves or fittings from the tank. See *Fuel Tank Draining Procedure*.

CAUTION

Be fully aware of the local regulations, NFPA codes and safety requirements for handling propane fuel prior to working on this vehicle.

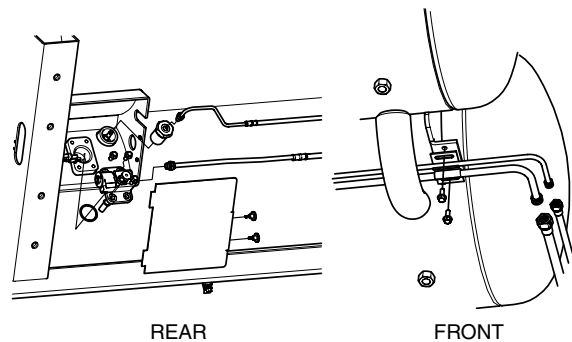
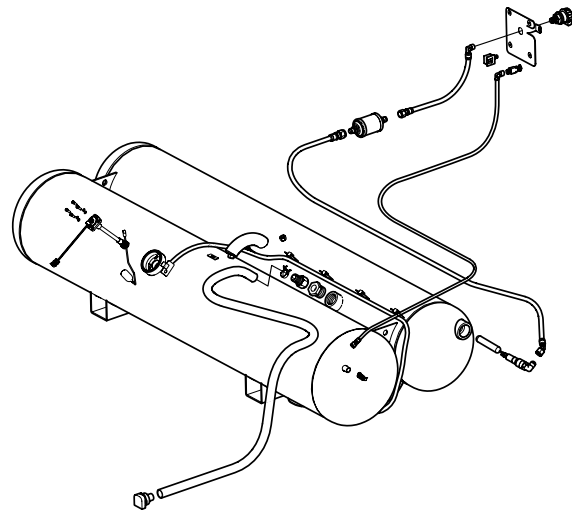

Figure 27 – Fuel Tank and Line Assembly

Removal

1. Purge the fuel lines using the *Fuel Line Purging Procedure*.
2. If the tank is being replaced or will be opened for service, drain the fuel tank using the *Fuel Tank Draining Procedure*.

NOTE: If the tank does not need to be serviced and will be removed with propane inside, be sure the manual shutoff and tank bleeder valves are securely closed.

3. Carefully disconnect the chassis flex lines from the tank mounted hard lines using the appropriate disconnect tools.
4. Remove bleed hose from the bleeder valve on the back of the tank.
5. Remove the fill hose from the fill valve on the back of the tank.

681



ROUSH CleanTech Blue Bird Vision Liquid Propane Autogas (LPA) Service Manual

6. Loosen and remove all nuts and carriage fasteners attaching the rear bumper to the vehicle.
7. Carefully remove rear bumper to prevent damage to the vehicle.
8. Remove the rear tow hooks and the tow hook cross member.



Figure 28 – Frame Brackets

9. Detach back up alarm harness from vehicle frame and ensure it is safely out of the way.
10. Remove six (6) fasteners attaching the rear tank cross member to the frame.
11. Remove four (4) fasteners attaching the rear tank cross member to the tank end guard.
12. Remove three (3) fasteners attaching the tank end guard to the tank support cross member. Remove the tank end guard and rear tank cross member.
13. Unplug the tank electrical connectors from the vehicle wiring harness located at the rear tank support cross member. Cut any nylon ties that will prevent easy removal.
14. Remove eight (8) fasteners attaching the tank to the tank support cross members.
15. Remove every other nut and bolt attaching the tank support cross members to the right and left hand tank barriers.
16. Loosen but DO NOT remove remaining nuts and fasteners.

17. Using suitable lifting device (hydraulic table, transmission jack, etc) lift tank from tank support cross members approximately 1". (Note: using 4x4 wooden blocks makes this much easier.)

CAUTION

Ensure tank is securely fastened to lifting device to prevent accidental dropping.

18. When tank is fully supported and stable on the lifting device, remove the four (4) tank support cross members toward the rear of the vehicle. The forward most bracket does not need to be removed for this operation.

Replacement

Reverse the above procedure (refer to torque chart for proper torques)

Once installed,

1. If the tank was drained and/or opened during the servicing, purge the fuel tank using the Fuel Tank Purging Procedure.
2. Confirm all fuel and electrical connections are secure, the battery is connected and the manual shut off valve is open.
3. Add 10 gallons of propane to the tank.
4. Leak Check the valves and fuel lines using an electronic leak detector or leak detection solution.
5. Reinstall fuel supply circuit cover.

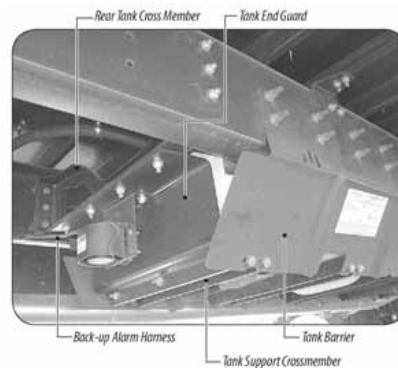

Figure 29 – Fuel Tank Frame Brackets and Shields





BLUE BIRD

ROUSH
 CLEANTECH

**ROUSH CleanTech Blue Bird Vision Liquid Propane Autogas (LPA)
 Service Manual**
**Tank Fill Valve/80% Overfill Prevention
 Device (OPD)**

Located on the rear end cap of the right hand cylinder.

CAUTION

Be sure the tank has been completely drained before removing the fill valve from the tank.

Removal

1. Purge the fuel lines using the *Fuel Line Purge Procedure*.
2. Drain the fuel tank using the *Fuel Tank Draining Procedure*.
3. Remove the fill line from the tank fill valve
4. Remove the 90 degree fitting from the fill valve
5. Remove the fill valve from the tank

Replacement

NOTE: The mark on the fill valve needs to face vertically upwards to work properly when installed. For ease of visibility after installation, a mark has been added to the face at the hex end of the fill valve see Figures 31 and 32.

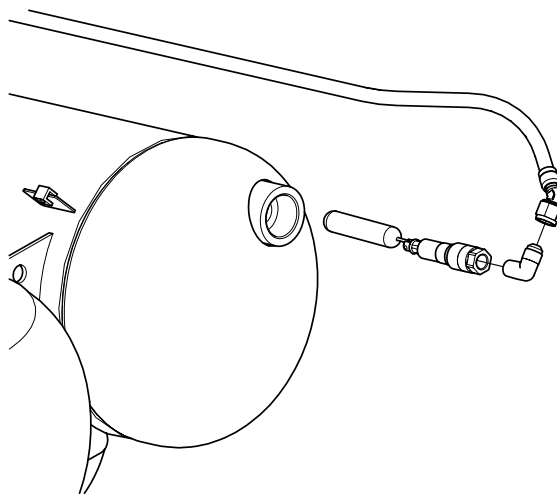

Figure 30 – Fuel Fill Valve/Overfill Prevention Device (OPD)
 Installation

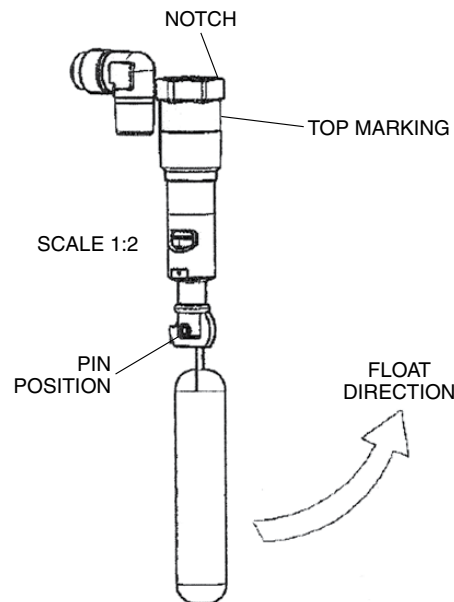

Figure 31 – Tank Fill Valve/Overfill Prevention Device

1. Install the new fill valve assembly into the tank. Torque to 75 Nm minimum, plus orientation, reverse torque not permissible.
2. If reusing, clean the threads and apply pipe thread sealant (Loctite 567 or equivalent) to the threads of the 90-degree fitting. Assemble the 90-degree fitting to the fill valve in the orientation shown in Figure 32. Torque fitting to 31 Nm minimum, plus orientation, reverse rotation is not permissible.
3. Reinstall the fill line to the valve and torque fill line to 45 +/- 0.4 Nm.
4. Purge the fuel tank using the Fuel Tank Purging Procedure
5. Reconnect the battery.
6. Fill tank and leak check the fitting using an electronic leak detector or an approved leak detection solution.

NOTE: The mark on the fill valve connector needs to face straight up to work properly when installed. For ease of visibility (after installation) add a mark at the end of the fitting with a marker before it is installed.

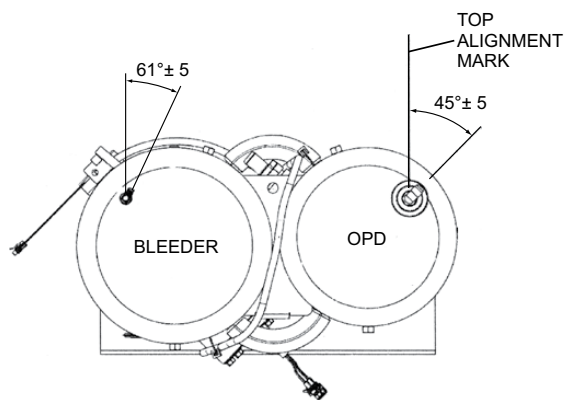

Figure 32 – Tank Bleeder and OPD Orientations

Tank Bleeder Valve

Located on the rear end cap of the left hand cylinder, see Figure 32.

CAUTION

Be sure the tank has been completely drained before removing the fill valve from the tank.

Removal

1. Purge the fuel lines using the *Fuel Line Purge Procedure*.
2. Drain the fuel tank using the *Fuel Tank Draining Procedure*.
3. Remove the bleeder line from the tank bleeder valve.
4. Remove the bleeder valve from the tank.

Replacement

1. Apply pipe thread sealant (LocTite 567 or equivalent) **ONLY** to the threads going into the tank.
2. Install the new bleeder valve assembly into the tank. Torque to 20 +/- 4.0 Nm minimum, plus orientation, reverse torque not permissible (see Figure 32).
3. Reinstall the bleeder line to the valve and torque to 18.5 +/- 3.0 Nm
4. Purge the fuel tank using the *Fuel Tank Purging Procedure*
5. Reconnect the battery.
6. Fill tank and leak check the fitting using an electronic leak detector or an approved leak detection solution.

Fuel Tank Pressure Relief Valve

CAUTION

Be sure the tank has been completely drained before removing the pressure relief valve from the tank.

Removal

1. Purge the fuel lines using the *Fuel Line Purging Procedure*.
2. Drain the fuel tank using the *Fuel Tank Draining Procedure*.
3. Remove the frame cross-member and shield behind the tank.
4. Disconnect the fuel pressure relief hose from the pipe away fitting on the tank.
5. Remove the pipe away fitting from Pressure Relief Valve (PRV).
6. Remove pressure relief valve from tank.

Replacement

1. Install the new pressure relief valve (thread sealant pre-applied) into the threaded coupling, torque to 120 Nm MIN plus 180-degrees.
2. Clean the threads of the pipe away fitting.
3. Apply thread sealant (LocTite 567 or equivalent) to the threads of the pipe away fitting.
4. Assemble the pipe away fitting to the pressure relief valve and Torque to 95 +/- 5 Nm
5. Purge the fuel tank using the *Fuel Tank Purging Procedure*.
6. Reconnect the fuel pressure relief valve hose and clamp.
7. Install the frame cross-member and tank shield.
8. Reconnect the battery.
9. Fill tank with propane.
10. Perform the *Fuel System Priming Procedure*.





BLUE BIRD

ROUSH
 CLEANTECH

**ROUSH CleanTech Blue Bird Vision Liquid Propane Autogas (LPA)
 Service Manual**
Tank Supply Circuit Assembly

Located on the bottom of the LH tank cylinder behind the supply circuit cover.

CAUTION

Be sure the tank has been completely drained before removing any of the supply valve components from the tank

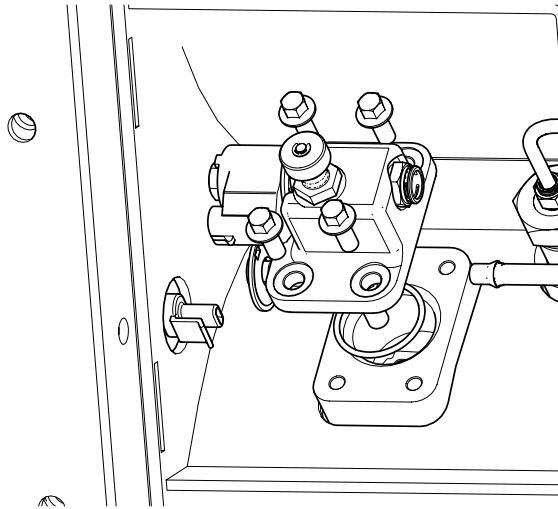

Figure 33 – Supply Circuit Assembly

Removal

1. Purge the fuel lines using the *Fuel Line Purging Procedure*.
2. Drain the fuel tank using the *Fuel Tank Draining Procedure*.

CAUTION

Ensure the battery ground wires are disconnected before proceeding.

3. Disconnect the chassis flex line from the supply line on the tank using the appropriate disconnect tool.
4. Remove the supply line bolt from the front tank support.
5. Remove the supply line at the valve using the appropriate disconnect tool.
6. Disconnect the supply solenoid electrical connection.
7. Open the remote bleeder valve to ensure there is no remaining pressure in the tank.

8. Remove the Four (4) bolts securing the valve to the tank.
9. Pull the *Supply Circuit Assembly* away from the tank.
10. Disconnect the internal fuel pump supply line by depressing the colored tabs on either side of the quick connect fitting and pulling it off the stem.

NOTE: Retain the fuel supply line with a clip to prevent it from slipping back into the fuel tank.

11. Remove and discard the o-ring from the bottom of the supply valve.

Replacement

NOTE: When replacing the *Supply Circuit Assembly*, the tank seat o-ring must be replaced.

1. Inspect the o-ring sealing surface and remove any debris.
2. Apply silicone o-ring lubricant (Parker Super Lube or equivalent) to the o-ring and install to the supply solenoid.
3. Lubricate the tip of the brass stem quick connect with a small amount of motor oil.
4. Connect the internal fuel pump supply line, push on until a “click” is heard, then tug to insure it is secured.
5. Slide the supply valve assembly to the tank seat.
6. While holding the supply circuit valve assembly, install the four (4) bolts and hand tighten.
7. Torque the bolts using the sequence and torques shown in Figure 34.
 - a. Initial Torque: Crossing pattern
2.5 +/- 0.5 Nm
 - b. Final Torque: Crossing pattern 25 +/- 5 Nm
8. Apply a small amount of motor oil to the tip of the supply line.
9. Install the supply line into the valve quick connect fitting and tug the line to ensure the connection is secure.
10. Close the remote bleeder valve.
11. Connect the wiring harness to the tank solenoid coil.
12. Secure the supply line to the front mounting bracket on the tank.

685



13. Connect the chassis flex line to the tank supply line.
14. Purge the fuel tank using the Fuel Tank Purging Procedure.
15. Connect the vehicle battery.
16. Install 10 gals of propane into the tank.
17. Check the supply valve and tank lines for leaks using an electronic leak detector or leak detection solution.
18. Reinstall the supply circuit cover and hand tighten the thumb screws.
19. Perform the *Fuel System Priming Procedure*.

BOLT TORQUE SEQUENCE
 1-4-3-2 SNUG 2-3 Nm
 1-4-3-2 20-30 Nm

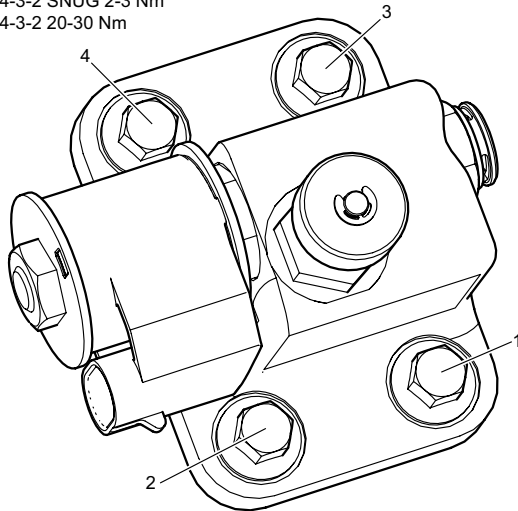

Figure 34 – Supply Circuit Torque Sequence

Removal – (Tank Solenoid Coil)

1. Remove the supply circuit cover, on the bottom of the tank, using the thumb screws.
2. Remove the electrical wire from the solenoid connector.
3. Close manual shutoff valve
4. Loosen and remove the nut at the top of the solenoid coil.
5. Slide the coil off the brass solenoid stem.

CAUTION

Do not attempt to loosen or remove the brass coil stem. This will allow propane to escape from the tank.

Replacement – (Tank Solenoid Coil)

1. Slide the new solenoid coil over the brass stem with the connector opening facing away from the valve.
2. Install the stem nut. Torque to 6.8 +/- 0.5 Nm.
3. Reconnect the electrical connector
4. Open manual shutoff valve
5. Reinstall the supply circuit cover and hand tighten the thumb screws.

NOTE: The Excess Flow and Manual Shut-Off Valves are non-serviceable components.

Fuel Tank Return Valve

Located on the bottom of the LH tank cylinder behind the supply circuit cover.

CAUTION

Be sure the tank has been completely drained before removing the return line or valve from the tank.

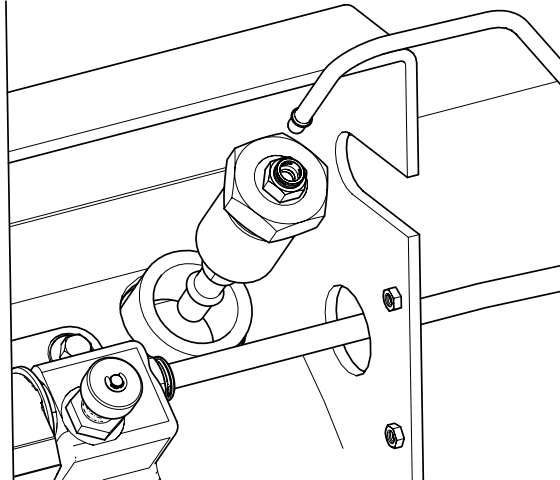

Figure 35 – Tank Return Circuit Assembly

Removal

1. Purge the fuel lines using the *Fuel Line Purging Procedure*.
2. Drain the fuel tank using the *Fuel Tank Draining Procedure*.
3. Disconnect the chassis flex fuel line from the hard lines on the tank
4. Remove the supply and return line bolts from the front tank support



**ROUSH CleanTech Blue Bird Vision Liquid Propane Autogas (LPA)
 Service Manual**

5. Remove the fuel supply and return lines from the valves using the appropriate disconnect tools.
6. Remove the return valve from the tank.
7. Remove the return hose from the return valve quick connect fitting.

NOTE: Retain the fuel return line with a clip to prevent it from slipping back into the fuel tank.

Replacement

1. If reusing, clean the threads before Install pipe thread sealant (Loctite 567 or equivalent) to the valve threads.

NOTE: Leave bottom 2-3 threads uncoated to reduce risk of adding a contaminant into the tank.

2. Connect the tank internal quick connect line to the valve and tug on it gently to confirm it is secured.
3. Install return valve to the tank and torque to 120 Nm minimum plus 180-degrees.
4. Lubricate the end of the fuel lines with a thin film of motor oil and connect the fuel lines to the valves and tug on them gently to confirm they are secure.
5. Secure fuel return line to the front tank support.
6. Lubricate the end of the fuel tank hard lines with oil and connect to the chassis flex lines and tug on them gently to confirm they are secure.
7. Purge the fuel tank using the *Fuel Tank Purging Procedure*.
8. Install 10 gallons of propane into the tank
9. Check line connections for leaks using an electronic leak detector or leak detection solution.
10. Reinstall the supply circuit cover and hand tighten the thumb screws.
11. Connect vehicle batteries.
12. Perform the *Fuel System Priming Procedure*.

Fuel Pump Assembly (In-Tank)

It is recommended to remove the tank from the vehicle using the Fuel Tank Removal Procedure.

Removal

1. Purge the fuel lines using the *Fuel Line Purge Procedure*.
2. Drain the fuel tank using the *Fuel Tank Draining Procedure*.

CAUTION

Ensure the battery ground wires are disconnected before proceeding.

3. Remove tank service cover from the tank, loosening bolts in a star-pattern.
4. Reach into fuel tank and disconnect fuel pump electrical connectors.
5. Release pump hose quick connects from in-tank filters.
6. Remove the center bolt and the (2) nuts that secure pump housing to tank bracket.
7. Remove pump assembly from fuel tank.

NOTE: Pumps are to be serviced as an assembly.

Replacement

1. Attach new pump assembly to tank bracket using center bolt (5.8 +/- 0.3 Nm) and two nuts (8.5 +/- 0.5 Nm).
2. Attach pump hose quick connects to in-tank filters.
3. Connect fuel pump electrical connectors.
4. Lubricate the tank supply cover o-ring with a small amount of motor oil and install it to the tank, driving bolts in a star-pattern.

NOTE: It is recommended to replace the service cover O-rings whenever the cover is removed.

5. Purge the fuel tank using the *Fuel Tank Purging Procedure*.
6. Reconnect battery.
7. Install 10 gallons of propane in the tank.
8. Check the supply valve and tank lines for leaks using an electronic leak detector or leak detection solution.
9. Reinstall the supply circuit cover and hand tighten the thumb screws.
10. Perform the *Fuel System Priming Procedure*.



ROUSH CleanTech Blue Bird Vision Liquid Propane Autogas (LPA) Service Manual

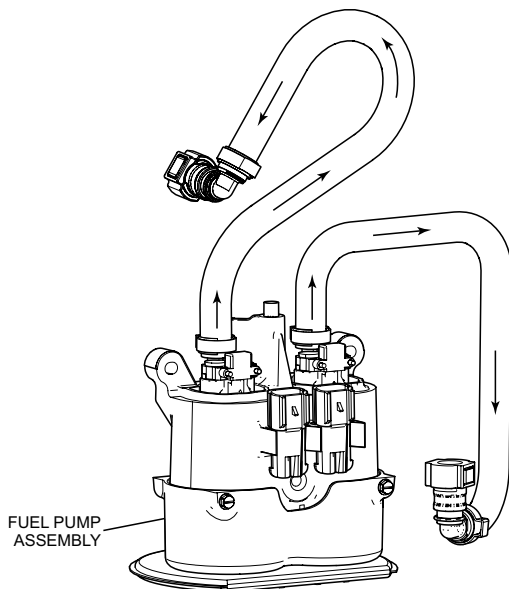

Figure 36 – Fuel Pump and Filter Assembly

- NOTE:** It is recommended to replace the service cover O-rings whenever the cover is removed.
3. Purge the fuel tank using the *Fuel Tank Purging Procedure*.
 4. Reconnect battery.
 5. Install 10 gallons of propane in the tank.
 6. Check the supply valve and tank lines for leaks using an electronic leak detector or leak detection solution.
 7. Reinstall the supply circuit cover and hand tighten the thumb screws.
 8. Perform the *Fuel System Priming Procedure*.

688

Fuel Filter and Hose Assemblies (In-Tank)

It is recommended to remove the tank from the vehicle using the Fuel Tank Removal Procedure.

Removal

1. Purge the fuel lines using the *Fuel Line Purge Procedure*.
2. Drain the fuel tank using the *Fuel Tank Draining Procedure*.

⚠ CAUTION

Ensure the battery ground wires are disconnected before proceeding.

3. Remove tank service cover from the tank, loosening bolts in a star-pattern.
4. Reach into fuel tank and disconnect the fuel hose connectors and remove hoses.
5. Slide filters up and out of their support brackets.
6. Remove filters from the fuel tank.

NOTE: In-tank hoses are serviced as a kit.

Replacement

1. Connect new hoses.
2. Lubricate the tank supply cover o-ring with a small amount of motor oil and install it to the tank, driving bolts in a star-pattern.



**ROUSH CleanTech Blue Bird Vision Liquid Propane Autogas (LPA)
Service Manual**

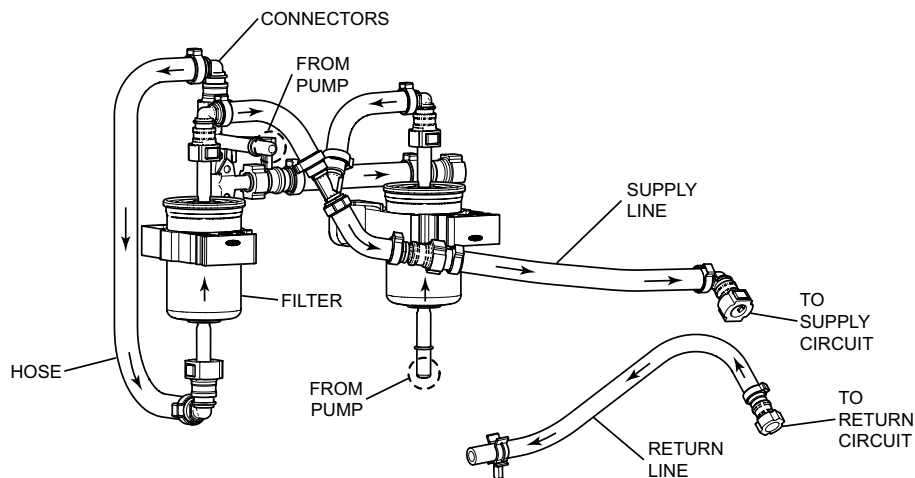

Figure 37 – In-Tank Lines and Filters

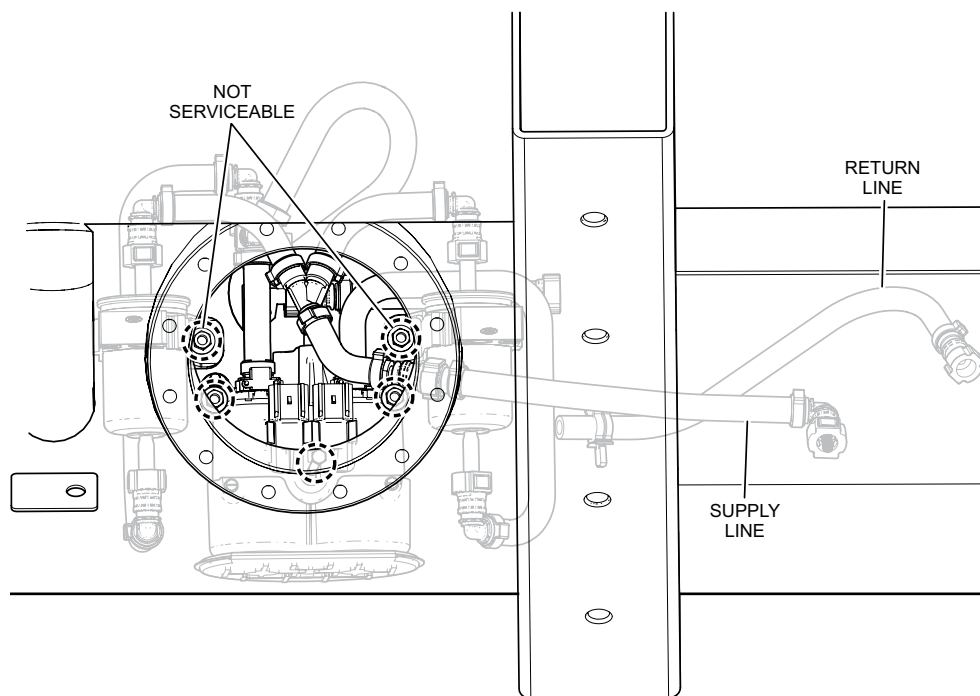

Figure 38 – Fuel Pump and Filter Assemblies Installed



Fuel Level Sender (located on top of the LH cylinder)

11. Perform *Fuel System Priming Procedure*.

Removal

1. Purge the fuel lines using the *Fuel Line Purge Procedure*.
2. Drain the fuel tank, using the *Fuel Tank Draining Procedure*.

⚠ CAUTION

Ensure the battery ground wires are disconnected before proceeding.

3. Lower the fuel tank using the *Fuel Tank Removal Procedure*.
4. Disconnect the wiring connector to the fuel level sender.
5. Open the tank bleeder valve.
6. Remove the four (4) fasteners securing the level sender to the cylinder.
7. Slide the level sender out of the tank.

Replacement

1. Install the new fuel level sender into the tank aligning it properly, see Figure 40.
2. Apply 1 drop of semi-permanent thread locker (Loctite 242 or equivalent) to each bolt.
3. Secure the level sender to the tank with four (4) bolts hand tight.
4. Torque the bolts in several steps in a crossing pattern until all screws are secure see Figure 40.
 - i. Torque all four bolts to 15 in-lbs
 - ii. Torque to 25 in-lbs
 - iii. Torque to 35-50 in-lbs
5. Connect wiring to fuel level sender.
6. Close the tank bleeder valve.
7. Install tank into vehicle using the *Fuel Tank Installation Procedure*.

NOTE: Since the tank was opened to replace the level sender, perform the *Fuel Tank Purging Procedure*.

8. Reconnect vehicle batteries.
9. Install 10 gallons of propane into tank.
10. Leak check all fuel line joints with an electronic leak detector or leak detection solution.

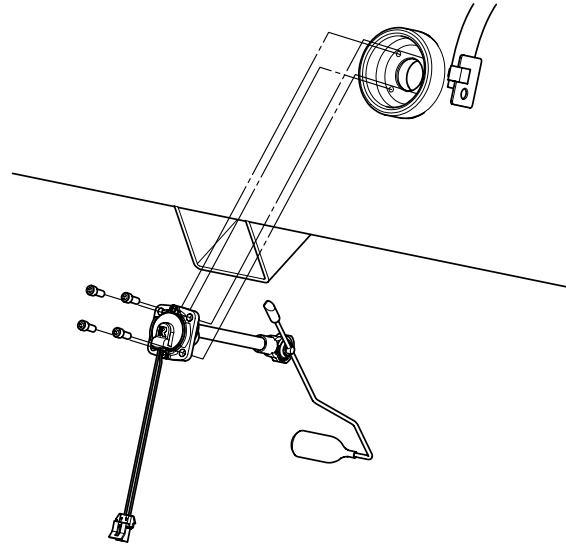

Figure 39 – Fuel Level Sender Installation

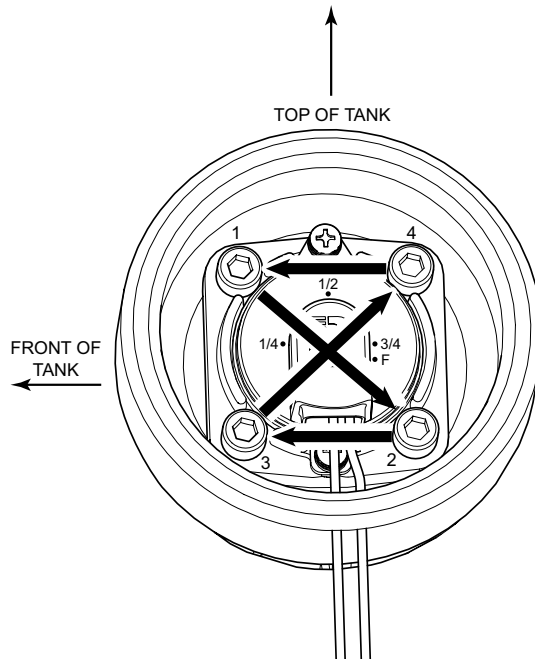

Figure 40 – Fuel Level Sender Torque Sequence



**ROUSH CleanTech Blue Bird Vision Liquid Propane Autogas (LPA)
Service Manual****Fuel Tank Wiring**

Two wiring harnesses are used on the fuel tank assembly. The fuel pump harness connects the in-tank pumps and routes outside the tank through the tank service cover where it connects to the vehicle wiring harness. The solenoid harness connects the fuel supply solenoid and fuel level sender on the tank to the vehicle wiring harness.



Figure 41 – Fuel Tank Connectors



ROUSH CleanTech Blue Bird Vision Liquid Propane Autogas (LPA) Service Manual

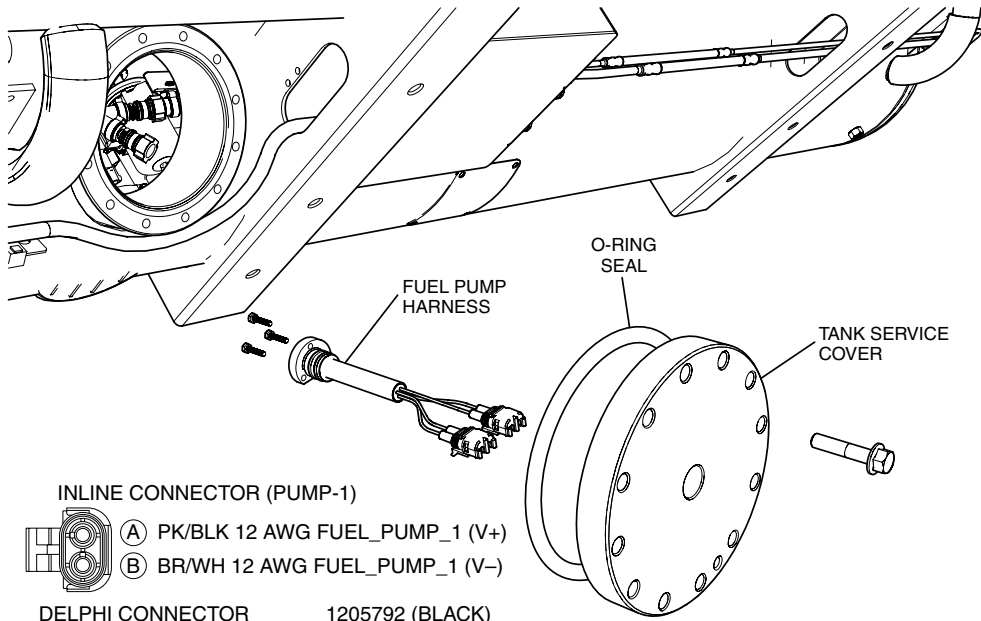

INLINE CONNECTOR (PUMP-1)

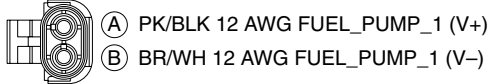

- DELPHI CONNECTOR 1205792 (BLACK)
- DELPHI 12 AWG TERMINAL 12124581
- DELPHI CABLE SEAL 15324981

INLINE CONNECTOR (PUMP-2)

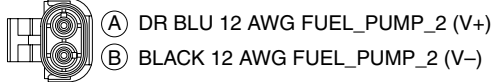

- DELPHI CONNECTOR 12103784 (LIGHT GRAY)
- DELPHI 12 AWG TERMINAL 12124581
- DELPHI CABLE SEAL 15324981

Figure 42 – Fuel Pump Wire Harness

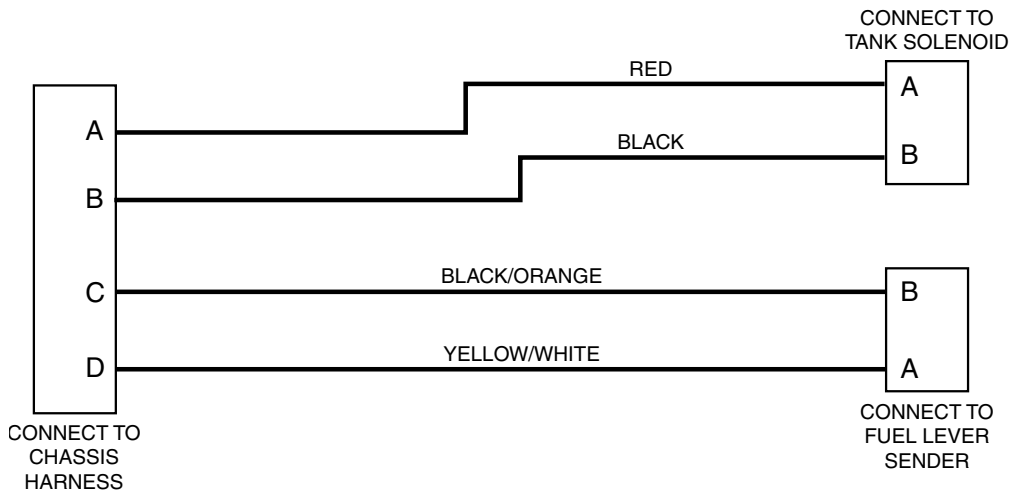

Figure 43 – Solenoid Wire Harness





BLUE BIRD

ROUSH
 CLEANTECH

**ROUSH CleanTech Blue Bird Vision Liquid Propane Autogas (LPA)
 Service Manual**
Remote Mounted Fuel Fill Valve

The LPA fuel system on this vehicle utilizes a remote mounted fill valve. The fill valve is located on the curb side of the vehicle attached to a bracket behind a locked fuel door. This valve connects to a fill hose, through a filter, to a second fill hose, then to the fill valve on the tank. The following procedure must be done outside and 50 feet away from any source of ignition.



Figure 44 – Remote Fill Valve, Remote Bleeder Valve and Fuel Door Switch

Removal

1. Drain the fill line by carefully loosening the fill hose that is connected to the back side of the fill valve. Allow all of the propane to drain before removing the fill hose from the valve.

NOTE: The tank overpressure prevention device (OPD) includes a back check valve, which only allows fuel flow into the tank. This will allow the fill hoses to be bled without losing any fuel in the tank.

2. Remove the fill valve to mounting bracket nut and separate the valve from the bracket.

Replacement

1. Attach the fill valve to the mounting bracket. Install the nut and tighten to the specified torque.
2. Attach the fill hose to the fitting on the fill valve and torque to 45 +/- 0.4 Nm.
3. Connect the fill valve to a fuel dispensing source to charge the line.
4. Leak check the fill line fitting at the valve using an electronic leak detector or leak detection solution.

Remote Fuel Fill Line(s)

This vehicle utilizes a remote fill device mounted on the curbside. The fill valve will be mounted to a bracket and a fuel line will be connected from the remote fill valve, through a filter, to the tank fill valve. To replace the remote line(s) use the following steps.

Removal

1. Remove any clamps or retainers on the fill line(s).
2. Slowly loosen the fitting(s) at the filter and drain the fill lines.

NOTE: The tank overpressure prevention device (OPD) includes a back check valve, which only allows fuel flow into the tank. This will allow the fill hoses to be bled without losing any fuel from the tank.

3. Loosen the fill line(s) at the remote mounted fill valve or tank OPD and remove the line.

Replacement

1. Connect the fill line to the fill valve or tank OPD and torque to 45 +/- 0.4 Nm.

NOTE: Thread sealant is NOT required on flare or compression fittings.

2. Connect the fill line(s) to the filter and torque to 57 +/- 0.4 Nm.
3. Connect the fill valve to a fuel dispensing source to charge the line.
4. Check all fittings for leaks using an electronic leak detector or leak detection solution.
5. Secure the fuel filter using the originally installed clamp and torque to 23 +/- 1.4 Nm.



ROUSH CleanTech Blue Bird Vision Liquid Propane Autogas (LPA) Service Manual

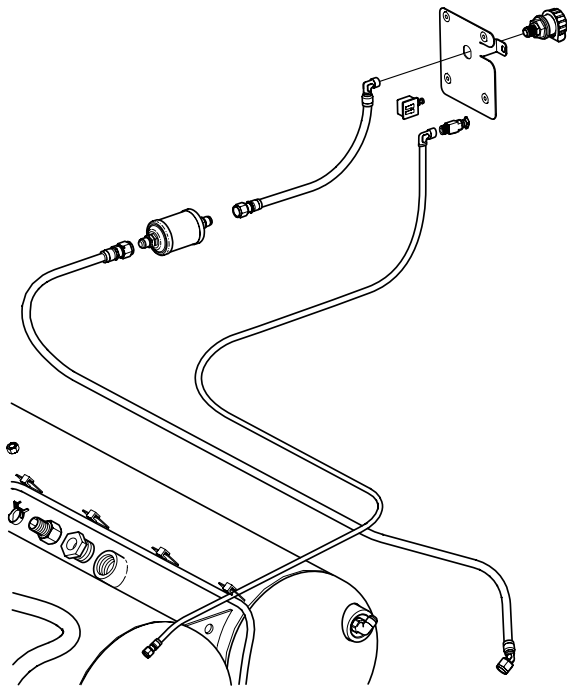

Figure 45 – Fuel Fill Circuit and Bleeder Line

2. Connect the fill valve to a fuel dispensing source to charge the line.
3. Check all fittings for leaks using an electronic leak detector or leak detection solution.
4. Secure the fuel filter using the originally installed clamp and torque.

Remote Mounted Bleeder Valve

The LPA fuel system on this vehicle utilizes a remote mounted bleeder valve. The bleeder valve is located on the curb side of the vehicle attached to a bracket behind a locked fuel door. This valve connects to a bleeder hose connected to the bleeder valve on the tank. The following procedure must be done outside and 50 feet away from any source of ignition.

Removal

1. Close the tank bleeder valve.
2. Open the remote bleeder valve to vent the line.

NOTE: If the remote bleeder valve does not stop venting within a few seconds, then the tank bleeder valve is not fully closed.

3. Disconnect the bleeder line from the back of the remote bleeder valve.
4. Remove the bleeder valve to mounting bracket nut and separate the valve from the bracket.

Replacement

1. Attach the bleeder valve to the mounting bracket. Install the nut and tighten to the specified torque.
2. Attach the bleeder hose to the fitting on the bleeder valve and torque to 18.5 +/- 3.0 Nm.
3. Confirm the remote bleeder valve is closed and open the tank bleeder valve.
4. Leak check the bleeder line fitting at the valve using an electronic leak detector or leak detection solution.

Remote Bleeder Line

Removal

1. Close the tank bleeder valve.
2. Open the remote bleeder valve to vent the line.

NOTE: If the remote bleeder valve does not stop venting within a few seconds, then the tank bleeder valve is not fully closed.

In-Line Fuel Filter



A trace amount of propane fuel will be released on loosening the fittings. It will settle to the lowest available surface before it dissipates into the atmosphere. Keep heat, sparks, flames, static electricity or other sources of ignition out of the area when venting or purging the fuel lines or tank. Failure to heed this danger can result in severe personal injury or property damage.

Removal

1. Slowly loosen the fitting(s) at the filter to drain the fill lines.
2. Disconnect the fuel fill line from the fuel filter inlet and outlet.
3. Remove the clamp retaining the fuel filter to the body.
4. Remove and discard the filter.

Replacement

1. Connect the fuel fill lines to the filter inlet and outlet and torque to 57 +/- 0.4 Nm.





BLUE BIRD

ROUSH
CLEANTECH**ROUSH CleanTech Blue Bird Vision Liquid Propane Autogas (LPA)
Service Manual**

3. Disconnect the bleeder line from the back of the remote bleeder valve.
4. Disconnect the bleeder line from the tank bleeder valve.
5. Remove line from vehicle.
4. Connect the vehicle batteries.
5. Open the manual shut-off valve on the fuel tank and install the supply circuit cover.
6. Perform the *Fuel System Priming Procedure*.
7. Check the fuel line connections for leaks using an electronic leak detector or leak detection solution.

Replacement

1. Route line in vehicle.

NOTE: 90-degree fitting connects to remote bleeder valve.

2. Attach the bleeder line to the tank valve and torque to 18.5 +/- 3.0 Nm.
3. Attach the bleeder hose to the remote bleeder valve and torque to 18.5 +/- 3.0 Nm.
4. Confirm the remote bleeder valve is closed and open the tank bleeder valve.
5. Leak check the bleeder line fittings using an electronic leak detector or leak detection solution.

**Fuel Rail Pressure Control Module
(FRPCM)****Removal**

1. Purge the fuel lines using the Fuel Line Purging Procedure.

CAUTION

Ensure the battery ground wires are disconnected before proceeding.

2. Disconnect the FRPCM electrical connector
3. Remove the fuel lines from the FRPCM using the appropriate disconnect tools.

NOTE: Mark lines appropriately to reinstall into the proper ports.

4. Remove the vapor line from the FRPCM by squeezing the release tabs on either side of the connector.
5. Remove the four (4) fasteners securing the FRPCM to the bracket.

Replacement

1. Install the new FRPCM to the bracket and torque to 12.8 +/- 0.6 Nm.
2. Install the fuel and vapor lines to the FRPCM, gently tugging each line to confirm it is secure.
3. Connect the wiring harness.

695



ROUSH CleanTech Blue Bird Vision Liquid Propane Autogas (LPA) Service Manual

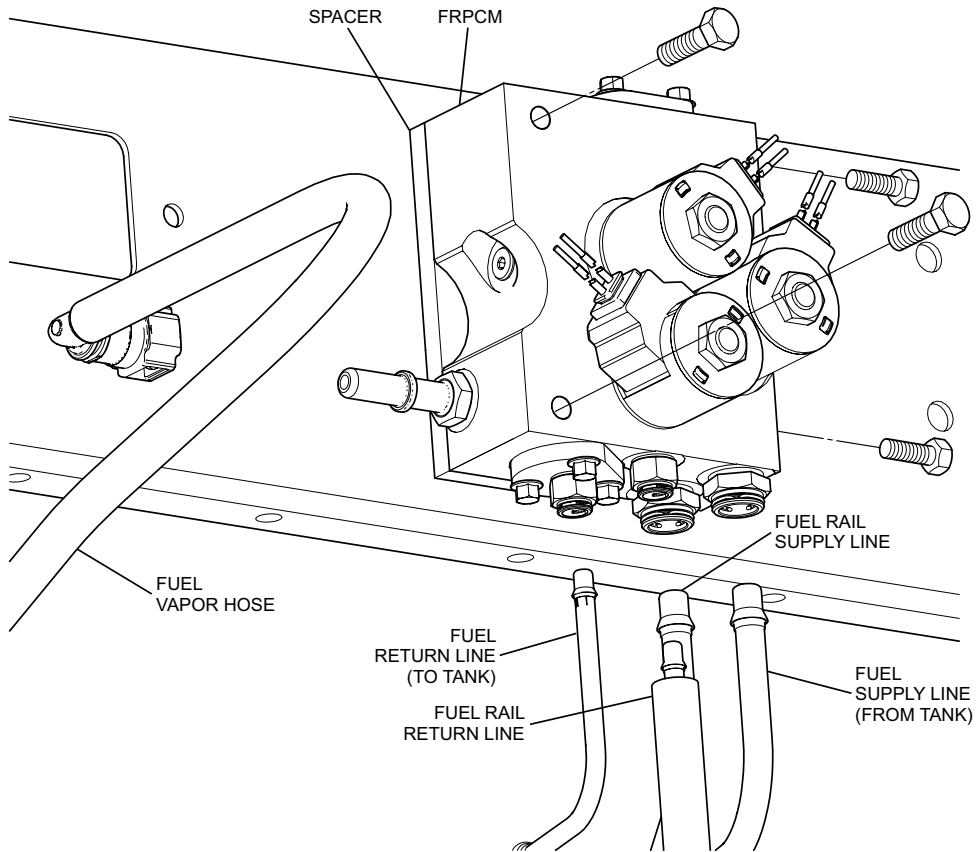

Figure 46 – Fuel Rail Pressure Control Module (FRPCM) Connections

696





BLUE BIRD

ROUSH
 CLEANTECH

**ROUSH CleanTech Blue Bird Vision Liquid Propane Autogas (LPA)
 Service Manual**
Fuel Supply and Return Line
⚠ WARNING

Technicians working with, or around, fuel systems should be properly trained to utilize extreme care and caution at all times. Failure to exercise extreme caution and care may lead to serious accidents which can result in property damage, personal injury and/or death.

The fuel supply and return lines are made of special material and should only be replaced or repaired using original equipment parts. The fuel line can be removed using the following procedure.

Removal (Fuel Line)

1. Purge the fuel lines using the *Fuel Line Purging Procedure*.

⚠ CAUTION

Ensure the battery ground wires are disconnected before proceeding.

2. Remove any securing clamps or retainers from the hose/line to be replaced.
3. Slowly disconnect one of the fuel line joints, using the appropriate disconnect tool, allowing any excess propane to dissipate into the atmosphere.

4. Disconnect the other end of the hose/line to be replaced.
5. Remove the hose/line from the vehicle.

⚠ WARNING

LPG is under pressure, wear adequate eye protection. When LPG is discharged into the atmosphere the rapid change in pressure can cause a refrigerant condition in the fuel and can harm your skin or cause serious burns, always wear gloves.

Replacement (Fuel Line)

1. Install hose/line in vehicle using the same routing and loosely secure the retaining features.
2. Connect the quick connect fitting and gently tug on the lines to make sure the connection is secure.
3. Tighten the hose/line retaining features.
4. Connect the vehicle batteries.
5. Open the manual shut-off valve on the fuel tank and install the supply circuit cover.
6. Perform the *Fuel System Priming Procedure*.
7. Check the fuel line and rail connections for leaks using an electronic leak detector or leak detection solution.

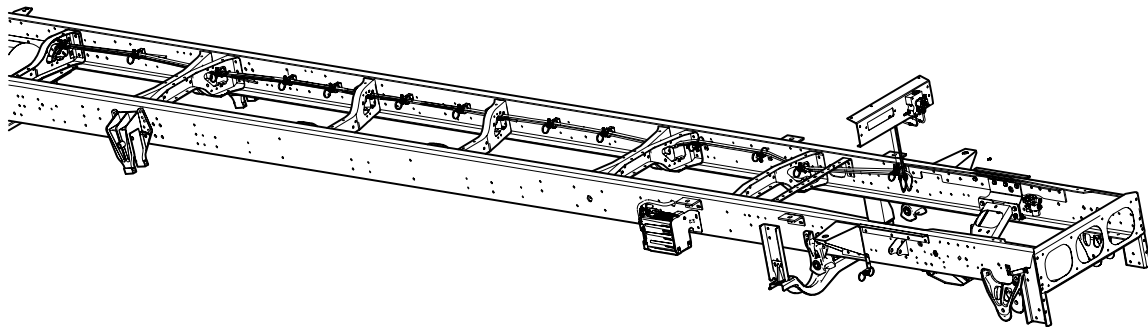

Figure 47 – Fuel Line Routing Along Frame

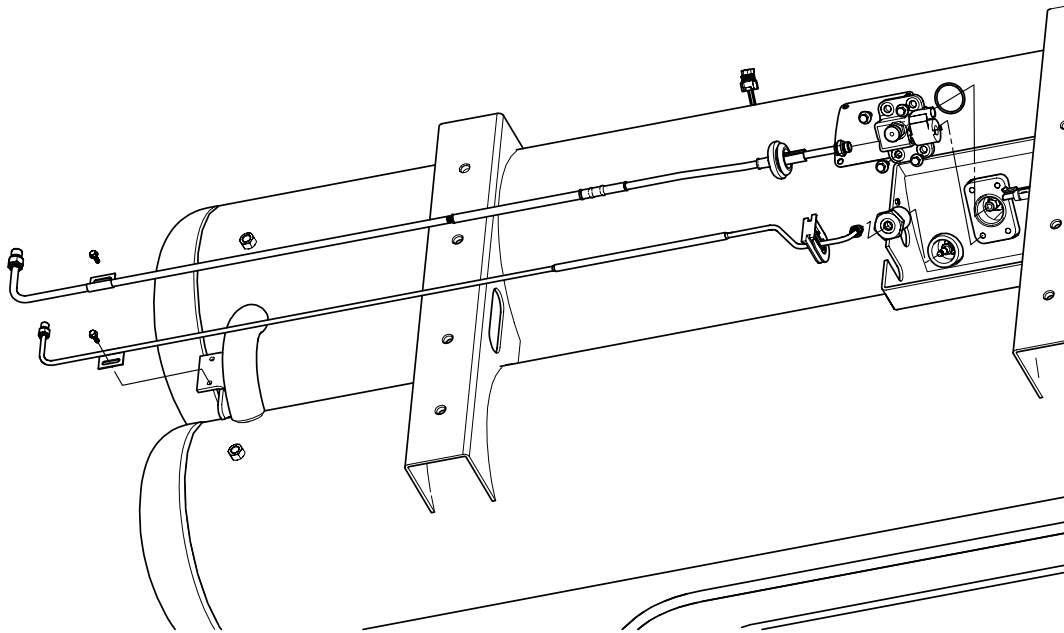

Figure 48 – Fuel Tank Hard Lines

698

Fuel Rail

CAUTION

When removing or replacing any fuel delivery components which include: Fuel Rails, Injectors, or Supply Lines, thoroughly clean the work area with solvents and compressed air to remove any debris or contaminants. Always insure your hands are clean when handling fuel injection components to prevent contaminating the fuel delivery systems.

CAUTION

Contamination may cause the injectors to stick, leak, or become damaged, delivering incorrect amounts of fuel and causing the fuel control system to be non-compliant.

NOTE: Always cap any open ports after disconnecting fuel lines, removing injectors or the fuel rails to prevent contamination of the fuel delivery system.

When removing the fuel rails use the following procedure.

Removal

1. Purge the fuel lines using the *Fuel Line Purging Procedure*.

CAUTION

Ensure the battery ground wires are disconnected before proceeding.

2. Disconnect the Injection Pressure and Temperature Sensor (IPTs) electrical connector.
3. Disconnect the fuel injector electrical connectors.
4. Disconnect the fuel rail supply and return hoses from the fuel rails.
5. Remove fuel rail mounting brackets from intake manifold.
6. Remove the fuel rail assembly.

Replacement

1. Lubricate injector spacer lower O-rings using SAE 5W20 motor oil or equivalent.

NOTE: It is recommended to replace the fuel rail O-rings during servicing.

2. Position fuel rail assemblies onto the intake manifold and fully seat the injector spacers.
3. Install and tighten fuel rail to intake manifold mounting brackets to the specified torque.
 - a. M5 Bolt: 5.8 +/- 1.2 Nm



BLUE BIRD

ROUSH
 CLEANTECH

**ROUSH CleanTech Blue Bird Vision Liquid Propane Autogas (LPA)
 Service Manual**

- | | |
|---|--|
| <p>b. M6 Bolts: 10 +/- 2 Nm</p> <p>4. Connect the fuel rail supply and return lines to the fuel rail quick connect fittings.</p> <p>5. Connect the fuel injector electrical connectors.</p> <p>6. Connect the Injection Pressure and Temperature Sensor (IPTTS) electrical connector.</p> | <p>7. Connect the vehicle batteries.</p> <p>8. Open the manual shut-off valve on the fuel tank and install the supply circuit cover.</p> <p>9. Perform the <i>Fuel System Priming Procedure</i>.</p> <p>10. Check the fuel line and rail connections for leaks using an electronic leak detector or leak detection solution.</p> |
|---|--|

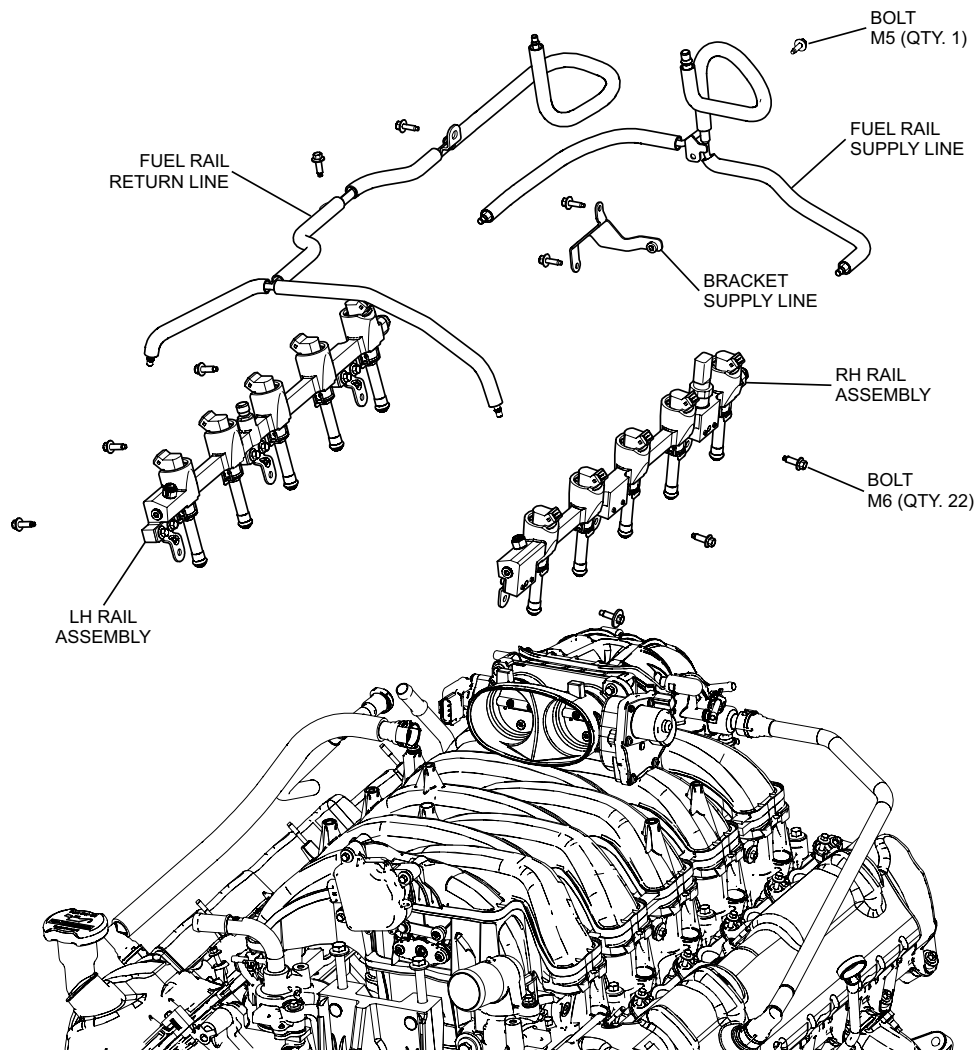

Figure 49 – Fuel Rail and Line Assembly

699



Fuel Injector

NOTE: It is possible to service the injector on the vehicle. However, clean the area thoroughly and blow the area clean with compressed air before starting.



When removing or replacing any fuel delivery components which include: Fuel Rails, Injectors, or Supply Lines, thoroughly clean the work area with solvents and compressed air to remove any debris or contaminants. Always insure your hands are clean when handling fuel injection components to prevent contaminating the fuel delivery systems.

If replacing one or more injectors use the following procedure.

Removal

1. Purge the fuel lines using the *Fuel Line Purging Procedure*.



Ensure the battery ground wires are disconnected before proceeding.

2. To release any residual propane in the lines, disconnect one of the fuel lines connected to the fuel rail. Once pressure is released, reconnect the line.
3. Disconnect the fuel injector electrical connector.
4. Remove the fuel injector retention c-clip.
5. Using a twisting motion, pull the fuel injector straight upward out of the fuel rail (a pair of pliers might be necessary to help remove the fuel injector). Use care to prevent damage to the fuel injector.
6. Repeat steps 2-5 as needed for the remaining fuel injectors.

Replacement

NOTE: Before removing the injector assembly from the package, clean the work area and your hands. Do not remove the protective caps until it is necessary.

1. Lubricate the upper and lower injector O-rings using SAE 5W20 motor oil or equivalent.
2. Install the fuel injector into the fuel rail, so that the electrical connection faces away from the intake manifold when the injector is fully seated. Place injector in position, then push straight down to ensure it is fully seated.

EXCEPTION: The RH rear fuel injector connector should face towards the intake manifold to provide proper clearance to the heater inlet tube on the engine.

3. Install the fuel injector retention c-clip and ensure it is fully engaged in the groove.
4. Connect the fuel injector electrical connector.
5. Repeat steps 1-4 as needed for the remaining fuel injectors.
6. Connect the vehicle batteries.
7. Perform the *Fuel System Priming Procedure*.
8. Check the fuel line and rail connections for leaks using an electronic leak detector or leak detection solution.





**ROUSH CleanTech Blue Bird Vision Liquid Propane Autogas (LPA)
 Service Manual**

Figure 50 – Fuel Rail Assembly Detail

Vapor Canister Assembly (see Figure 4)
Removal

1. Disconnect load/purge hose from canister by disconnecting the quick connect fitting.
2. Disconnect fresh air line from canister by disconnecting quick connect fitting.
3. Remove canister to bracket mounting bolts and remove the canister.
4. Remove bracket to frame rail mounting bolts and remove the brackets.

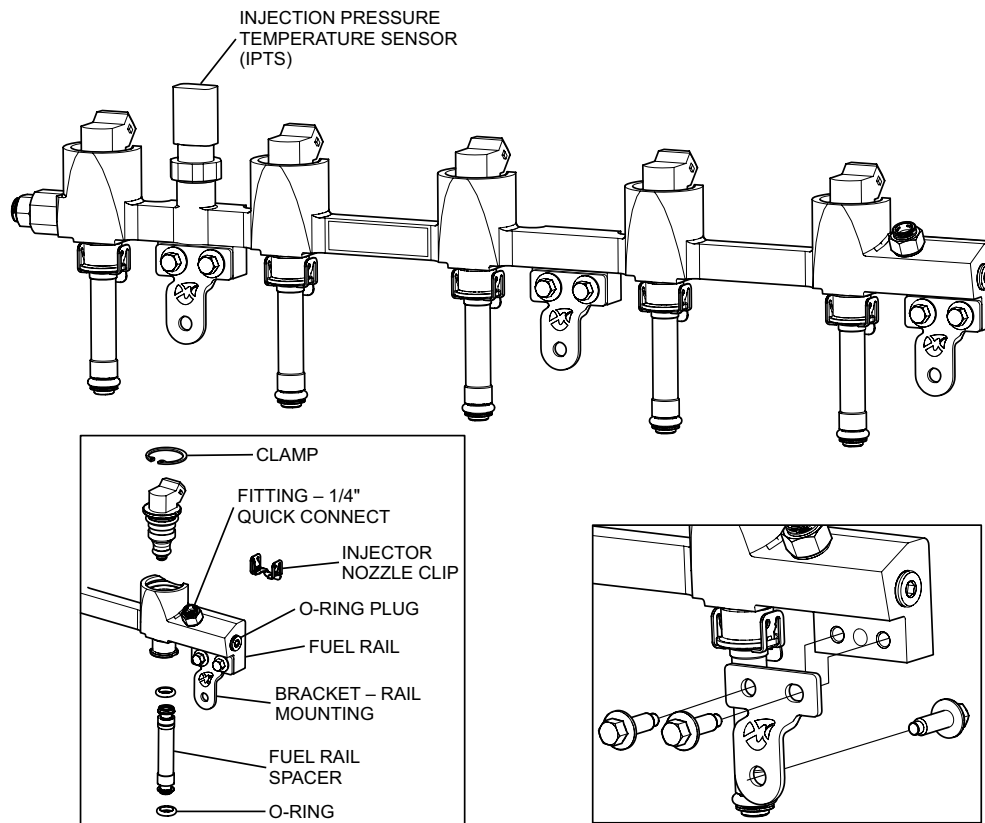
Replacement

1. Install the canister mounting brackets onto the frame rail and tighten to the specified torque.
2. Place the canister onto the mounting brackets and tighten bolts to the specified torques.
 - a. M6 Bolts: 6.0 +/- 0.3 Nm
 - b. Thread Cutting Bolts: 2.75 Nm +/- 0.25 Nm
3. Install the fresh air line to the canister
4. Install the load/purge hose onto the canister

NOTE: There is an audible “click” when the quick connects are installed properly



Smart Relay Module

The LPA fuel system utilizes a Smart Relay Module (SRM). It interrupts the ground signal to the original fuel pump control relay to control the purge timing and the wait to start indicator. It also controls the tank overfill prevention circuit. To replace the SRM use the following procedure.

Removal

1. Disconnect the negative ground cables from the vehicle batteries.



Ensure battery is disconnected before proceeding.

2. Disconnect the main harness connector at the SRM.
3. Remove the four (4) mounting nuts and retain.
4. Remove the SRM.

Replacement

1. Install the SRM to the isolators using the four bolts and torque to 11.5 +/- 0.5 Nm.
2. Connect the main harness connector to the SRM.
3. Push until you hear the click then pull on the connector to ensure the connector is locked.
4. Connect the vehicle batteries.



Figure 51 – Smart Relay Module

SYSTEM MAINTENANCE

LPA Fuel System

This section covers the items in the LPA fuel system, which requires regularly scheduled maintenance. For maintenance of the base engine or transmission refer to the 2012 Ford F650 service manual at www.motorcraft.com or consult the local Ford Medium Duty Truck Service Center.

Fuel Tank

The fuel tank equipped has been certified to ASME Tank and Pressure vessel requirements and the installation complies with all NFPA Pamphlet 58 Standards in affect at the time of certification. State and or local regulatory agencies may require a periodic inspection of the LPG tank. At a minimum of every 12 months the LPG tank should be inspected by a trained technician for the following items:

- Check for impact damage, dents, cuts or severe gouging or any tank deformation.
- Check for rust and paint flaking.
- Check for cracks in the welded seams or mounting brackets.
- Check to insure the service valves or shut off valves are functioning and manually closes the valve.
- Check to insure the pressure relief valve vent is clear of any obstructions and is properly orientated.
- Check all electrical connections to insure they are properly seated and have not become corroded.
- Check all mounting fasteners and brackets to insure the tank is properly fitted to the chassis.
- Leak check all external fittings and connection.

If during the tank inspection any or all the above have been observed you should have the tank repaired by a certified LPG Tank Repair Facility or replace the tank.



Never cut or weld on the LPG fuel tank. Repairs to the fuel tank should only be made by a certified LPG tank repair facility. Failure to observe this warning could result in serious bodily injury, death and/or serious property damage.



**ROUSH CleanTech Blue Bird Vision Liquid Propane Autogas (LPA)
 Service Manual**
Fuel Filters

The fuel fill filter is the only filter that requires periodic maintenance every 50,000 miles. The in-tank filters are rated for full vehicle life and do not require scheduled maintenance.

Fuel Supply and Return Line

It is recommended that the fuel line connections be inspected for damage annually or anytime the lines have been removed. The routing of the lines should also be inspected annually to ensure that the lines have not come into contact with any sharp edges, rotating devices, hot surfaces or are located where they may be impacted by road debris.

Fuel Rail Pressure Control Module

The FRPCM does not require any periodic adjustment. You should annually inspect the following items:

- Check the mounting of the FRPCM to make sure the body, valves and fuel lines are secure.
- Check the FRPCM wiring to make sure the wiring and connectors are not damaged.
- Leak check the fuel line connectors using an electronic leak detector or an approved leak detection solution.

Fuel Rails and Injectors

The fuel rails and injectors require no periodic adjustment. You should annually inspect the following items on the fuel rails and injectors:

- Check to make sure the rail brackets are securely attached to the intake manifold.
- Check to make sure the rail brackets have no signs of cracks or breaks.
- Check to make sure that each injector is retained in the fuel rail.
- Leak check all of the connections on the fuel rail at each injector connector and the inlet and outlet fitting at the rail using an electronic leak detector or an approved leak detection soap solution.

With the engine running use an electronic leak detector or an approved leak detection soap solution to check the FRPCM to intake manifold and all hose connections for leaks

Electrical System

The electrical system and wiring harnesses do not require any periodic adjustments. You should annually inspect the following items:

- Check the SRM fasteners to ensure they are securely fastened and the rubber is in good condition.
- Check the SRM electrical connector and insure the connector is securely attached and locked.
- Check the wire harness routing under the hood to ensure the main harness and injector harness have not come into contact with any rotating devices, hot surfaces or have come loose from their securing points and are hanging in an unsafe location.
- Check all electrical connectors by lightly pulling on each connector to ensure the connector is fully locked and seated.
- Check all wire ties used to secure the harness for cracking, splitting or breakage and replace if necessary.
- Check the harness routing to the fuel tank connector and ensure the harness is securely attached to the frame and protected from any hot surfaces, rotating devices or road debris and repair any unsafe conditions.
- Check the wiring on the fuel tank to make sure it is secure and undamaged.

TORQUE CHART

Fuel Tank and Vehicle Components		
Component	Quantity	Torque (Nm)
Remote Fill Valve	1	Hand Tight + 1/4 to 1/2 turn
Remote Pressure Relief Outlet	1	Hand Tight + 1/4 turn
Remote Bleeder Valve		Hand Tight + 1/4 to 1/2 turn
Fuel Fill Line	1	"At Filter: 57.0 +/- 0.4 At Valve: 45.0 +/- 0.4"
Fill Filter Clamp Bolt	1	23.0 +/- 1.4
Bleeder Hose	1	18.5 +/- 3.0
Fuel Tank Assembly	1	-----
Fuel Tank Line Bolts – M5	2	5.8 +/- 0.3
Pressure Relief Outlet	1	95 +/- 5
Fuel Level Sender Screws – 1/4"	4	See Procedure
Bleeder Nozzle	1	20 +/- 4 MIN plus Orientation
Tank Access Cover Bolts – 3/8"	12	See Procedure
Fuel Filler - Tank OPD	1	75 MIN plus Orientation
Fuel Return Circuit Assembly	1	120 Nm + 180-Deg
Fuel Supply Circuit Bolts – M8	4	See Procedure
Fuel Pump Housing to Tank Bolt – M5	1	5.8 +/- 0.3
Fuel Pump Wiring Bolts - M4	3	2.7 +/- 0.4
Fuel Pump Housing and Filters to Tank – M6 nuts	4	8.5 +/- 0.5
Fuel Pump Housing – #6 Screw	4	5.0 +/- 0.5 in-lbs
Pressure Relief Valve	1	120 MIN + 1/2 Turn
Supply Circuit Cover – M5 Thumb Screw	2	Hand Tight
Fuel Rail and Line Assembly		
Component	Quantity	Torque (Nm)
Fuel Rail Supply Line Bolt – M5	1	5.8 +/- 1.2
Fuel Rail & Supply Line Bolts – M6	21	10 +/- 2
O-ring Plug	2	8.9 +/- 0.9
Fitting – 1/4" Quick Connect	4	21 +/- 1
Injection Pressure and Temperature Sensor (IPTS)	1	7 +/- 1
Evaporative System and Forward Fuel Components		
Component	Quantity	Torque (Nm)
Vapor Canister Bracket Bolts – Self Threading	3	2.75 +/- 0.25
Vapor Canister Bracket Bolts – M6	2	6.0 +/- 0.3
Vapor Canister to Frame Fasteners – M10	4	65.0 +/- 13.3
Smart Relay Module Bolt – 1/4"	4	11.5 +/- 0.5
FRPCM Bolts – M6	4	12.8 +/- 0.6



BLUE BIRD

ROUSH
CLEANTECH**ROUSH CleanTech Blue Bird Vision Liquid Propane Autogas (LPA)
Service Manual****FAQS****ROUSH CleanTech Technical Assistance**

Technical issues involving starting, operating or re-fueling a propane power bus should be reported to your local qualified service provider. In the event further technical assistance is needed, you should first contact your authorized Blue Bird Dealer regarding any technical issues with your Blue Bird product.

In emergency situations or if immediate technical assistance is needed and the above mentioned technical assistance is unavailable you can call ROUSH CleanTech Customer Service at 800.59.ROUSH (597-6874) with any questions regarding ROUSH CleanTech Liquid Propane Autogas Systems.

Q) How long should it take for my vehicle to start once I have cycled the key to on?

A) Typically the time will vary between seven (7) and fifteen (15) seconds, depending on the temperature of the fuel. Under severe operating circumstances (hot day, hot engine), the delay could be up to forty-three (43) seconds. Do not hold ignition in start position or engage starter multiple times. See "Starting" section under Features and Controls.

Q) How long will it take to fill my ROUSH CleanTech System fuel tank?

A) Normal refueling rates are typically between five (5) and eight (8) gallons per minute but may vary depending on the ambient temperature conditions and pump capacity of the refueling equipment being used.

Q) Why does my refueling take longer when it's hot out?

A) On a hot day, refueling may take longer than usual because the heat will raise the pressure inside the fuel tank, which must be overcome by the refueling equipment.

Q) Is any special liquid propane autogas fuel required?

A) Yes, motor vehicles require the use of HD-5 automotive grade liquid propane autogas. Other grades of propane (including HD-10 or "commercial-grade") may contain higher levels of contaminants and could cause premature failure of fuel pumps and injectors, or clogging of system components. If you are unsure about the quality of your propane, check with your retailer or distributor.

Q) Where are liquid propane autogas filling stations located?

A) There are over 3,000 liquid propane autogas retail outlets available around the country to fill your vehicle. Liquid propane autogas filling locations can be found at these websites:

www.afdc.energy.gov/afdc/locator/stations

www.roushcleantech.com

Q) Can I perform my own service or repair on the Roush CleanTech System?

A) Not recommended. Most states require a licensed technician to work on liquid propane autogas systems. We recommend that you go to a Blue Bird/Roush CleanTech Authorized Service Center for any service or repair to your vehicle. To locate a ROUSH CleanTech Authorized Service Center near you, visit us at www.roushcleantech.com or call us between the hours of 8 AM and 5 PM Eastern Time, Monday through Friday, at 800.59.ROUSH (800.597.6874).

Q) Can I add additional liquid propane autogas tanks?

A) No. Adding tanks to the vehicle would potentially violate emissions compliance of the vehicle and could result in drivability and emissions issues.

Q) Are there any unique maintenance requirements for the ROUSH Propane System?

A) Yes. There is a fuel filter in the fuel fill line to prevent contamination during refueling. This filter is replaced at 50,000 mile intervals. No other ROUSH CleanTech System parts require periodic service. Some states require periodic certification of the tank or filling systems, see your local gas association or state regulating agency for additional information.

NOTE: To maintain your warranty coverage, you must follow the normal maintenance schedule for your Blue Bird vehicle.

Q) Who do I contact for LPA warranty-related issues?

A) Take your vehicle to a Blue Bird/Roush CleanTech Authorized Service Center or, if not readily available, to any Ford dealer that is authorized to repair ROUSH CleanTech propane vehicles.



For further information about ROUSH CleanTech Systems or to locate a ROUSH CleanTech Authorized Service Center near you, visit us at www.roushcleantech.com or call us between the hours of 8 AM and 5 PM Eastern Time, Monday through Friday, at 800.59.ROUSH (800.597.6874).

Q) Can I use any fuel additives?

A) No. It will void your warranty and harm the operation of the ROUSH CleanTech System installed on your vehicle.

SPECIAL CONDITIONS

Refueling



Before refueling, extinguish all open flames and smoking materials. Ensure that no electrical sparks are present. Failure to heed this danger may result in serious personal and property damage.



Stop refueling if there is any difficulty with the refueling process or the dispensing equipment. Notify the station operator at once. Failure to heed this danger may result in serious personal injury and property damage.

The filler cap screws on and off the filler valve. The filler nozzle also screws on and off the filler valve. Before attaching the filler nozzle, inspect the valve O-ring. If the O-ring is missing or damaged, replace it before attaching the filler nozzle.

Allow a station attendant to refuel your vehicle if you are not trained in proper liquid propane autogas refueling procedures and safety precautions. Ensure that the vehicle rests on level ground and that the engine is not running.

NOTE: Failure to refuel on a level surface may result in an incomplete or overfill condition.

Troubleshooting – Refueling

My vehicle does not fill at all:

- In order for the system to fill, the fuel supply pressure from the pump must be at least 50 psi higher than tank pressure (required to open the check valve in the fill system). Check the following:
 - If the vehicle fuel tank is significantly warmer than the station storage tank, the station fuel pump may not be able to provide sufficient

pressure (either due to insufficient pump capacity or a low bypass pressure setting). This can be a particular problem if the station fuel tank is underground and the vehicle is fueling on a hot day.

- If the fuel tank is over 3/4 full (indicated), or if the fuel tank is over 1/2 full and the vehicle is not level, it may be possible that the OPD is in the closed position due to fuel level at the location of the OPD. If vehicle is not level, turn the vehicle around and try to refill with vehicle pointed in the opposite direction. If vehicle is level, or if this does not change behavior, drive vehicle until indication is under 1/2 tank and attempt to fill again. If behavior repeats, take vehicle to qualified service center for diagnosis and repair.
- If fuel tank is under 1/2 full (indicated), and there is sufficient fuel pressure from the fuel pump (minimum 50 psi over tank), the OPD may be stuck closed. Diagnosis and repair by qualified service center is likely required.

My vehicle fills slowly (less than three (3) gallons/minute):

- If the vehicle is filling slowly, it indicates that the OPD is functioning properly but something in the system is preventing normal flow.
 - Confirm that fueling station has fueling equipment rated for Autogas applications (7.5 hp pump). Lower capacity pumps may be acceptable for cylinder fills but can result in slow fills in automotive applications.
 - If tank temperature is very high, the density of propane in the tank is relatively low which can result in higher than normal restriction and slow fill. This is most likely at temperatures above 100°F ambient, especially if station has underground storage tanks. This does not indicate any problem with the vehicle. We suggest trying to fill in the morning (when vehicle and station are at similar temperatures), or trying another filling station.
 - Fuel filter may be clogged. The inline fuel filter should be changed every 50,000 miles. If it has not been changed on schedule, have it changed by qualified technician. The technician should measure pressure drop to determine whether it has clogged prematurely (this is possible if the fuel has unusually high levels of contaminants).





BLUE BIRD

ROUSH
 CLEANTECH

**ROUSH CleanTech Blue Bird Vision Liquid Propane Autogas (LPA)
 Service Manual**

- If filter has less than 50,000 miles, take vehicle to qualified service center for fuel fill system diagnosis/repair.

My vehicle does not fill completely (shuts off early):

- During the fill event, it is possible for the tank pressure to increase causing the check valves to close. See “My vehicle does not fill at all”.
 - Make sure vehicle is level (either due to the fill station pavement, or to loading of the vehicle), the shutoff may occur early. Turn vehicle in temperature and vehicle tanks are usually at or above ambient.
- The OPD system is required to be inspected annually to verify proper function, and may be inspected more frequently based on local or fleet-specific requirements. Check the OPD inspection label (located on driver's door pillar) to determine whether OPD has been recently inspected.
- Verify fuel tank is level. If tank is tilted away from the fill valve, some overfilling could result. Within reason, this should not result in any issues, but if fill area is severely non-level, it should be corrected.
- If consistent overfill is suspected, have the full OPD inspection procedure performed to verify correct operation.
- Fuel tanks which are overfilled may vent propane unexpectedly, due to normal ambient temperature changes. Use caution if overfilled tank is suspected.

Troubleshooting – Starting

If the engine does not start within a few seconds of cranking, one touch integrated starting (OTIS) will disengage the starter. Check the fuel gauge before attempting to start again. If there is adequate liquid propane autogas fuel and the engine fails to start after several attempts, obtain the assistance of a qualified liquid propane autogas service technician to diagnose the problem. We recommend that you take your vehicle to a Blue Bird/ROUSH CleanTech Authorized Service Center to have such diagnosis performed. To locate a ROUSH CleanTech Authorized Service Center near you, visit us at www.roushcleantech.com or call us between the hours of 8 AM and 5 PM Eastern Time, Monday through Friday, at 800.59.ROUSH (800.597.6874).

THE VEHICLE DOES NOT START:
The starter does not engage even after 40 seconds:

- Most common cause of no-start/no-crank is either that the PCM did not recognize the request for crank, or that the key did not remain in the “on” position after being turned to start. Turn key to off and repeat start sequence, making sure to firmly turn the key to the start position, and then allowing the key to return to “on” without overshooting back to “off” or “accy”.
- Ensure transmission is in Neutral with parking brake engaged.
- Confirm vehicle battery is sufficiently charged and no other issues present.
- Check vehicle fuse panel for blown fuses
- If fuel pumps can be heard (roughly 1-2 seconds after turning the key to start), but starter does not engage, it likely indicates an issue with the vehicle unrelated to the propane system. If fuel pumps are not heard, there may be an issue where the propane system is not recognizing the start attempt. In either case, vehicle likely will need to be serviced.

THE VEHICLE DOES NOT START:
The starter engages but engine does not start or starts and will not keep running:

- Confirm adequate fuel in the tank. On level road, tank indication at or above indicated “E” should be sufficient for starting; vehicles parked on grades (either front/rear or side/side) may experience lack of starting at indication of 1/8 tank.
- Ensure battery is properly charged, and turn off all electrical accessories. Propane fuel injectors operate at higher pressures than gasoline and can fail to open in low battery conditions (such as experienced in crank), especially in hot conditions. Turn off headlights, radio, A/C, etc. If issue is repeatedly seen, take vehicle to qualified service center for investigation/repair of charging system or propane system.
- The ROUSH CleanTech starting system attempts to achieve liquid conditions in the fuel rail prior to engaging the starter. However, if the system does not achieve known liquid conditions in under thirty (30) seconds, it will attempt to start the engine (to avoid excessively long delays in extreme conditions). If the engine cranks but does not start, and there are no other indications



ROUSH CleanTech Blue Bird Vision Liquid Propane Autogas (LPA) Service Manual

of faults, key the engine off and attempt to start again. If vehicle continues not to start, or frequently requires multiple attempts, vehicle should be taken to qualified dealer for service.

The vehicle does start and run, but delay seems excessive:

- Due to the unique properties of liquid propane, vaporization in the rail is not always easy to predict and therefore long delays may be encountered unexpectedly. The following conditions are likely to result in longer delays:
 - Vehicle fully warm, engine off for 5-90 minutes. This is a long enough condition for heat to build in the rail, but not so long for engine to cool down.
 - Engine compartment fully warm, with tank relatively cool (below 60°F). In this condition, the rail needs to cool significantly prior to start. Generally starting in this condition is not a problem, but the delay may seem unusually long.
 - Engine compartment fully warm, tank very warm (above 110°F). In this condition, rail pressure is extremely high and the fuel is not much cooler than the rail.
- If you do believe that the crank delay times are consistently excessive, take the vehicle to qualified service center for inspection and repair if necessary.

MAINTENANCE AND SPECIFICATIONS

ROUSH CleanTech System Use and Maintenance

Use, maintenance, service and repair of the ROUSH CleanTech System must be in accordance with regulations put forth by the NFPA in their pamphlets #54 and #58, by the American Society of Mechanical Engineers (ASME), the Department of Transportation (DOT), the American National Standards Institute (ANSI) and all applicable federal, state, provincial and local authorities. Among those responsible for compliance are the maintenance provider, refueler and end-user personnel.

Service Recommendations

It is strongly recommended that all service needs for the engine and fuel system of the ROUSH CleanTech System installed on your vehicle be

referred to a qualified liquid propane autogas service technician. Working with pressurized liquid propane autogas that fuels an internal combustion engine requires special training. Technical issues involving starting, operating or re-fueling a propane power bus should be reported to your local qualified service provider. In the event further technical assistance is needed, you should first contact your authorized Blue Bird Dealer regarding any technical issues with your Blue Bird product.

In emergency situations or if immediate technical assistance is needed and the above mentioned technical assistance is unavailable you can call ROUSH CleanTech Customer Service at 800.59. ROUSH (597-6874) with any questions regarding ROUSH CleanTech Liquid Propane Autogas Systems.

Identifying ROUSH CleanTech System Components

Fuel Filter

There is a fuel filter in the fill line through which the liquid propane autogas fuel passes before entering the ROUSH CleanTech System tank. Its purpose is to prevent contamination during refueling. Have this inline filter replaced every 50,000 miles by a qualified liquid propane autogas service technician. Failure to replace the filter as specified can result in slow fuel fills as well as premature failure of the ROUSH CleanTech System components.

WHAT YOU SHOULD KNOW ABOUT LIQUID PROPANE AUTOGAS

Important Safety Precautions

Liquid propane autogas is stored under pressure at all times so that useful quantities can be held in easily-managed containers.

Always use HD-5 automotive grade liquid propane autogas. It is formulated especially for use as an automotive fuel for liquid propane autogas systems like the ROUSH CleanTech System.

The ROUSH CleanTech System does not permit the use of portable containers, such as gasoline cans and barbecue tanks, to transfer propane to the vehicle.

The fuel system of the ROUSH CleanTech System has an OPD which stops the flow of liquid propane autogas into the tank when the maximum allowable fill level has been reached.





BLUE BIRD

ROUSH
 CLEANTECH

**ROUSH CleanTech Blue Bird Vision Liquid Propane Autogas (LPA)
 Service Manual**
**Procedure for Reporting Liquid Propane Autogas
 Leaks**

1. Eliminate any potential source of ignition. Turn the vehicle OFF and remove the key from the ignition.
2. If you see, hear or smell the leak after removing the key, call appropriate emergency personnel first.
3. Call ROUSH CleanTech at 800.59.ROUSH (800.597.6874) to arrange for service. If calling after normal phone hours and if liquid propane autogas is still leaking, follow the automated phone instructions for emergency reporting.
4. Arrange for service by an approved liquid propane autogas service facility before refueling (vehicles with leaks may not be refueled prior to repair). We recommend that you use a Blue Bird/ROUSH CleanTech Authorized Service Center to address any issues concerning liquid propane autogas leaks.

⚠ DANGER

Liquid propane autogas can cause serious injury or death if exposed to fire or sparks. Ensure that all smoking materials and other sources of extreme heat are kept away from liquid propane autogas fuel and fuel handling areas. Failure to heed this danger may result in serious personal injury or death.

⚠ DANGER

The fuel system is under pressure at all times. Proceed with caution when refilling the tank. Escaped liquid propane autogas fuel, if trapped, may ignite or explode. Failure to heed this danger may result in serious personal injury or death.

⚠ DANGER

Ensure that there is adequate ventilation around the liquid propane autogas fuel dispensing area. A short hissing sound may be heard when disconnecting the delivery line from the filler line. This indicates that a trace quantity of liquid propane autogas has escaped. This is normal. It dissipates very quickly into the atmosphere and presents no threat unless an accumulation is trapped in an enclosed space. Failure to heed this danger may result in serious personal injury or death.

⚠ WARNING

Do NOT use bare hands to check for leaks. Liquid propane autogas is extremely cold (-44°F) as it is released to atmosphere and turns to vapor. The extremely cold liquid propane autogas fuel can cause severe frost bite. Failure to heed this warning may result in serious personal injury.

⚠ WARNING

The installation, service or repair of the ROUSH CleanTech System by a person who is not licensed or registered to perform installation, service or repair to liquid propane autogas systems may result in personal injury, harm, or loss or damage to property. Contact a person licensed or registered to fit install, service or repair a liquid propane autogas system. A person licensed to install, service or repair a liquid propane autogas system may not be liable for damages caused by the modification of a liquid propane autogas system by an unlicensed person except as otherwise provided by applicable law. Failure to heed this warning may void your ROUSH CleanTech System warranty. We recommend that you go to a Blue Bird/ROUSH CleanTech Authorized Service Center for installation or repair of the ROUSH CleanTech System.

⚠ WARNING

Each ROUSH CleanTech System has been specially developed and designed by ROUSH CleanTech for its intended vehicle application. Therefore, the ROUSH CleanTech System must not be installed on vehicles other than the intended vehicle application designated by ROUSH CleanTech. Additionally, the ROUSH CleanTech System must not be modified or altered (either before installation or at any time after installation, or as part of any service, maintenance or repair, etc., to the vehicle or the ROUSH CleanTech System), except as specifically directed by ROUSH CleanTech as part of a safety recall, technical service bulletin or other formal written direction by ROUSH CleanTech. Modification or alteration of the ROUSH CleanTech System without ROUSH's prior written authorization may void the ROUSH CleanTech Limited Warranty.

Refill Capacity

The Blue Bird bus is designed with a dual cylindrical manifold tank assembly, which will hold approximately 67.8 gallons of usable fuel.



ROUSH CleanTech Blue Bird Vision Liquid Propane Autogas (LPA) Service Manual

NOTE: There is typically 8-10% of the usable tank capacity remaining once “Low Fuel” lamp light illuminates below this level. It is possible to experience drivability issues related to fuel pressure when operating on grades, hard accelerating and cornering.

NOTE: The density of the liquid propane changes significantly with temperature. On a hot day, it is not unusual for vehicle to apparently fill less than usual, and for the fuel gauge to read less than full after the tank cools off. This is normal and does not indicate a problem with the fill system.

Jump Starting



Before attempting electrical connections for jump starting, check for battery and liquid propane autogas fumes. If there is any indication of a propane leak (rotten egg smell, ice buildup or visible vapor around fittings, audible hiss, etc.), follow the leak reporting procedure. Do not attempt to start the vehicle — sparks from the electrical connections may ignite the vapors. Failure to heed this danger may result in serious personal injury, including death and property damage.

Follow the jump starting procedures in the Driver’s Manual.

NOTE: It may take up to thirty (30) seconds for the engine to crank after initiating the start sequence.

Manual Shutoff Valve

Should the need arise (leaking or electrical failure, etc.) to stop the flow of liquid propane autogas manually, there is a manual shutoff valve on the liquid supply line of the ROUSH CleanTech System. The supply valve is located on the bottom of the ROUSH CleanTech System fuel tank; specific location of the valve is labeled on the tank. An access cover may be removed to allow access to the manual shutoff valve. Turn the knob clockwise, until it stops, to stop the flow of liquid propane autogas.

NOTE: Open this valve slowly when the system is restored to normal. Releasing liquid propane autogas quickly into an empty line may set off a special check valve restricting proper fuel flow. If difficulty occurs, close the valve completely and then open it slowly.

NOTE: This valve must always be fully open during vehicle operation.

Service needs for the liquid propane autogas fuel system should be referred to a qualified liquid propane autogas service technician for inspection and correction. We recommend that you see a Blue Bird/ROUSH CleanTech Authorized Service Center to address any service needs you may have.

Storing the Vehicle

If the vehicle is to be stored for more than sixty (60) days, close the manual shutoff valve of the ROUSH CleanTech System and consult the Driver’s Manual for information about protecting the base vehicle.

NOTE: Remember to open this valve slowly before returning the vehicle to operation.

Repainting (Vehicle or Tank)

The fuel tank should not be repainted. Touchups, if required, should be performed according to National Fire Protection Association (NFPA) NFPA58. Repainting the tank for purposes other than touching up or repair may result in voiding the tank warranty.



Remove the ROUSH CleanTech System fuel tank before attempting to paint the vehicle. The high temperatures used in the painting process can set off the pressure relief valve, discharging liquid propane autogas into the hot chamber causing asphyxiation that could result in personal injury, including death.

Tank removal should be performed by a qualified liquid propane autogas service technician. We recommend that you see a Blue Bird/ROUSH CleanTech Authorized Service Center to have this procedure performed.

Technical issues involving starting, operating or re-fueling a propane power bus should be reported to your local qualified service provider. In the event further technical assistance is needed, you should first contact your authorized Blue Bird Dealer regarding any technical issues with your Blue Bird product.

In emergency situations or if immediate technical assistance is needed and the above mentioned technical assistance is unavailable you can call ROUSH CleanTech Customer Service at 800.59. ROUSH (597-6874) with any questions regarding ROUSH CleanTech Liquid Propane Autogas Systems.

710





BLUE BIRD

ROUSH
 CLEANTECH

**ROUSH CleanTech Blue Bird Vision Liquid Propane Autogas (LPA)
 Service Manual**
DIAGNOSTIC TROUBLE CODES (DTC) — LPA-FUELED VEHICLES
Flow Control Solenoid (FCS)
P0090 — Fuel Pressure Regulator Circuit Open

Description	FCS circuit fault. Smart relay module (SRM) monitors FCS circuit for open and short circuit faults.
Possible Causes	<ul style="list-style-type: none"> • Short to voltage • Water in the harness connector • Open power circuit • Open ground (GND) circuit • Low battery voltage • Corrosion • Incorrect connections • Damaged FCS coil • Blown Fuse
Symptom	Fuel pressure in the rail does not change when commanded. Extended fuel rail flush time.
Diagnostic Aid	Check the fuel rail pressure control module (FRPCM) and SRM electrical connector for damage, corrosion and water intrusion.
Action	Go to <i>Fuel Rail Pressure Control Module (FRPCM) Electrical Check</i> procedure under <i>Diagnostic Tests and Procedures — LPA-Fueled Vehicles</i> .

Bleed Solenoid
P009E — Fuel Pressure Relief Control Performance Stuck Off

Description	Fuel rail failed to bleed. The powertrain control module (PCM) measures fuel rail pressure on key-up to determine if fuel rail has been properly bled.
Possible Causes	<ul style="list-style-type: none"> • Bleed solenoid did not open • Fuel rail pressure control module (FRPCM) check valve leaked • FRPCM supply solenoid leaked • FRPCM vapor port (bleed rate restrictor) clogged • Evaporative (EVAP) line kinked • Blown Fuse
Symptom	Fuel pressure present in the fuel rail after bleed event should have occurred; this may result in hard starts.
Diagnostic Aid	Check that FRPCM bleeds fuel from rail. Leaks to FRPCM can also trigger a fault.
Action	Bleed solenoid circuit fault. The smart relay module (SRM) monitors bleed solenoid circuit for open and short circuit faults.

711



P009B — Fuel Pressure Relief Control Circuit Open

Description	Bleed solenoid circuit fault. The smart relay module (SRM) monitors bleed solenoid circuit for open and short circuit faults.
Possible Causes	<ul style="list-style-type: none"> • Short to voltage • Water in the harness connector • Open power circuit • Open ground (GND) circuit • Low battery voltage • Corrosion • Incorrect connections • Damaged bleed solenoid (BS) coil
Symptom	Fuel rail bleed system does not operate correctly. There is a potential for fuel odor or hard start.
Diagnostic Aid	Check the fuel rail pressure control module (FRPCM) and SRM electrical connectors for damage, corrosion and water intrusion.
Action	Go to the <i>Fuel Rail Pressure Control Module (FRPCM) Electrical Check</i> procedure under <i>Diagnostic Tests and Procedures — LPA-Fueled Vehicles</i> .

712

Tank Supply Solenoid

P0005 — Fuel Shutoff Valve A Control Circuit Open

Description	Tank solenoid circuit fault. The smart relay module (SRM) monitors tank solenoid circuit for open and short circuit faults.
Possible Causes	<ul style="list-style-type: none"> • Short to voltage • Water in the harness connector • Open power circuit • Open ground (GND) circuit • Low battery voltage • Corrosion • Incorrect connections • Damaged tank solenoid (TS) coil • Blown Fuse
Symptom	Vehicle does not start. The pump runs but no pressure builds in the fuel rail.
Diagnostic Aid	Check the fuel rail pressure control module (FRPCM) and SRM electrical connectors for damage, corrosion and water intrusion.
Action	Go to the <i>Tank Solenoid Electrical Check</i> procedure under <i>Diagnostic Tests and Procedures — LPA-Fueled Vehicles</i> .



**ROUSH CleanTech Blue Bird Vision Liquid Propane Autogas (LPA)
 Service Manual**
Fuel Rail Pressure Control Module (FRPCM) Supply Solenoid and Wiring
P26B5 — Fuel Shutoff Valve B Function Check

Description	Fuel supply solenoid stuck. The smart relay module (SRM) monitors fuel rail pressure before and after the solenoid was commanded open. If the pressure rise is below a threshold, the fault is set.
Possible Causes	<ul style="list-style-type: none"> • Electrical fault • Damaged supply solenoid (SS) coil • Damaged SS armature • Excess flow valve tripped • Tank solenoid stuck closed • Tank manual valve closed • Fuel pumps do not power on • Blown Fuse
Symptom	Vehicle does not start. The pump runs but no pressure builds in the fuel rail.
Diagnostic Aid	Check the fuel rail pressure control module (FRPCM) and SRM electrical connectors for damage, corrosion and water intrusion.
Action	Go to the <i>Engine Cranks, No Start</i> procedure under <i>Diagnostic Tests and Procedures — LPA Fueled Vehicles</i> .

P2665 — Supply Solenoid Circuit Fault

Description	Fuel rail pressure control module (FRPCM) supply solenoid circuit fault. Smart relay module (SRM) monitors supply solenoid circuit for open and short circuit faults.
Possible Causes	<ul style="list-style-type: none"> • Short to voltage • Water in the harness connector • Open power circuit • Open ground (GND) circuit • Low battery voltage • Corrosion • Incorrect connections • Damaged supply solenoid (SS) coil • Blown Fuse
Symptom	Vehicle does not start. The pump runs but no pressure builds in the fuel rail.
Diagnostic Aid	Check the FRPCM and SRM electrical connectors for damage, corrosion and water intrusion.
Action	Go to the <i>Fuel Rail Pressure Control Module (FRPCM) Electrical Check</i> procedure under <i>Diagnostic Tests and Procedures — LPA-Fueled Vehicles</i> .



SRM, CAN Bus Circuit Wiring

U0108 — Lost Communication with Alternative Fuel Control Module

Description	Lost communication with smart relay module (SRM). The powertrain control module (PCM) monitors controller area network (CAN) bus communication for missing messages from the SRM. If the messages are continuously missing, a fault is set.
Possible Causes	<ul style="list-style-type: none"> • Wiring between the SRM and PCM • No power to the SRM • Blown Fuse
Symptom	Rough idle.
Diagnostic Aid	Check the fuel rail pressure control module (FRPCM) and SRM electrical connectors for damage, corrosion and water intrusion. Check for power at the SRM.
Action	Go to the <i>Smart Relay Module (SRM) Electrical Check</i> procedure under <i>Diagnostic Tests and Procedures — LPA-Fueled Vehicles</i> .

Fuel System

P0148 — Fuel Delivery Error

Description	Liquid propane autogas (LPA) system is operating in vapor space. At least one bank is lean at wide open throttle (WOT).
Possible Causes	<ul style="list-style-type: none"> • Severely restricted fuel filter • Severely restricted fuel supply line • Damaged or worn fuel pump • Damaged or contaminated mass air flow (MAF) sensor • Excess flow valve tripped • Tank solenoid (TS) or supply solenoid (SS) closed • Tank manual shutoff valve not completely open
Symptom	Vehicle hesitation or stall condition.
Diagnostic Aid	—
Action	Go to the <i>Engine Cranks, No Start</i> procedure under <i>Diagnostic Tests and Procedures — LPA-Fueled Vehicles</i> .

P116E — Maximum Pressure

Description	Maximum injection pressure reached. The powertrain control module (PCM) monitors fuel rail pressure and battery voltage. Based on these measurements, the PCM adjusts fuel pump speed to stay below the maximum operating pressure of the injectors.
Possible Causes	<ul style="list-style-type: none"> • Operating the vehicle in high ambient conditions • Vehicle operated in a low voltage condition
Symptom	Vehicle hesitation, stall, rough idle, misfire or no start.

714





BLUE BIRD

ROUSH
 CLEANTECH

**ROUSH CleanTech Blue Bird Vision Liquid Propane Autogas (LPA)
 Service Manual**

Diagnostic Aid	The P116E code is meant as an indication that the fuel system was operated at the limits of the system. The customer may have experienced drive issues although the system is performing as expected.
Action	Go to the <i>Maximum Pressure Check</i> procedure under <i>Diagnostic Tests and Procedures — LPA-Fueled Vehicles</i> .

P0171, P0174 — System Too Lean (Bank 1 and Bank 2)

Description	Refer to the <i>Ford Powertrain Control/Emissions Diagnosis Service Manual</i> for more descriptive information.
Possible Causes	<ul style="list-style-type: none"> • The liquid propane autogas (LPA) system was operated in the vapor region • Refer to the <i>Ford Powertrain Control/Emissions Diagnosis Service Manual</i> for a list of other causes at www.motorcraft.com (2012 F-650 H561).
Symptom	—
Diagnostic Aid	Verify that no LPA system faults are present and then follow the Ford service manual procedure.
Action	Go to the <i>Fuel Pressure Drop Check</i> procedure under <i>Diagnostic Tests and Procedures — LPA-Fueled Vehicles</i> .

P03xx – Misfire

Description	Refer to the <i>Ford Powertrain Control/Emissions Diagnosis Service Manual</i> for more descriptive information.
Possible Causes	<ul style="list-style-type: none"> • The liquid propane autogas (LPA) system was operated in the vapor region • Refer to the <i>Ford Powertrain Control/Emissions Diagnosis Service Manual</i> for a list of other causes at www.motorcraft.com (2012 F-650 H561).
Symptom	—
Diagnostic Aid	Verify that no LPA system faults are present and then follow the Ford service manual procedure under <i>Diagnostic Tests and Procedures — LPA-Fueled Vehicles</i> .
Action	Go to the <i>Fuel Pressure Drop Check</i> procedure.

Heated Exhaust Gas Oxygen (HEGO) Sensor
P2195, P2197 — HEGO Stuck

Description	Refer to the <i>Ford Powertrain Control/Emissions Diagnosis Service Manual</i> for more descriptive information.
Possible Causes	<ul style="list-style-type: none"> • The liquid propane autogas (LPA) system was operated in the vapor region • Refer to the <i>Ford Powertrain Control/Emissions Diagnosis Service Manual</i> for a list of other causes at www.motorcraft.com (2012 F-650 H561).
Symptom	—
Diagnostic Aid	Verify that no LPA system faults are present and then follow the Ford service manual.
Action	Go to the <i>Fuel Pressure Drop Check</i> procedure under <i>Diagnostic Tests and Procedures — LPA-Fueled Vehicles</i> .



Integrated Pressure Temperature Sensor (IPTS)

P0182 — Fuel Temperature Sensor A Circuit Low

Description	The smart relay module (SRM) reads the integrated pressure temperature sensor (IPTS) and passes the voltage reading over the controller area network (CAN) bus to the powertrain control module (PCM). The PCM monitors the voltage as if the sensor were plugged into the vehicle.
Possible Causes	<ul style="list-style-type: none"> • CAN bus fault between the SRM and PCM • Wiring fault between IPTS and SRM • Short in harness • Voltage reference (VREF) open or short • Low ambient temperature operation • Incorrect harness connection • Damaged IPTS (or fuel temperature sensor FTS) • IPTS failure • SRM failure
Symptom	—
Diagnostic Aid	Verify the fuel rail temperature parameter ID (PID) value to determine open or short.
Action	Go to the <i>Integrated Pressure Temperature Sensor (IPTS) Electrical Check</i> procedure under <i>Diagnostic Tests and Procedures — LPA-Fueled Vehicles</i> .

P0183 — Fuel Temperature Sensor A Circuit High

Description	The smart relay module (SRM) reads the integrated pressure temperature sensor (IPTS) and passes the voltage reading over the controller area network (CAN) bus to the powertrain control module (PCM). The PCM monitors the voltage as if the sensor were plugged into the vehicle.
Possible Causes	<ul style="list-style-type: none"> • CAN bus fault between the SRM and PCM • Wiring fault between IPTS and SRM • Open circuit • Open or short to voltage in harness • Incorrect harness connection • Damaged IPTS (or fuel temperature sensor FTS) • IPTS failure • SRM failure
Symptom	—
Diagnostic Aid	Verify the fuel rail temperature parameter ID (PID) value to determine open or short.
Action	Go to the <i>Integrated Pressure Temperature Sensor (IPTS) Electrical Check</i> procedure under <i>Diagnostic Tests and Procedures — LPA-Fueled Vehicles</i> .

716





BLUE BIRD

ROUSH
 CLEANTECH

**ROUSH CleanTech Blue Bird Vision Liquid Propane Autogas (LPA)
 Service Manual**
P0190 — Fuel Pressure Sensor A Circuit

Description	The smart relay module (SRM) reads the integrated pressure temperature sensor (IPTS) and passes the voltage reading over the controller area network (CAN) bus to the powertrain control module (PCM). The PCM monitors the voltage as if the sensor were plugged into the vehicle.
Possible Causes	<ul style="list-style-type: none"> • CAN bus fault between the SRM and PCM • Wiring fault between IPTS and SRM • Voltage reference (VREF) open in harness • VREF open in sensor • Vacuum leaks • IPTS failure • SRM failure
Symptom	—
Diagnostic Aid	VREF should be between 4–6 volts.
Action	Go to the <i>Integrated Pressure Temperature Sensor (IPTS) Electrical Check</i> procedure under <i>Diagnostic Tests and Procedures — LPA-Fueled Vehicles</i> .

P0192 — Fuel Pressure Sensor A Circuit Low

Description	The smart relay module (SRM) reads the integrated pressure temperature sensor (IPTS) and passes the voltage reading over the controller area network (CAN) bus to the powertrain control module (PCM). The PCM monitors the voltage as if the sensor were plugged into the vehicle.
Possible Causes	<ul style="list-style-type: none"> • CAN bus fault between the SRM and PCM • Wiring fault between IPTS and PCM • IPTS fuel rail pressure (FRP) signal short to signal return (SIG RTN) or power ground (PWR GND) • Damaged IPTS (or FRP) • IPTS failure • SRM failure
Symptom	—
Diagnostic Aid	A FRP parameter ID (PID) value during ignition ON, engine OFF, or ignition ON, engine running is less than 0.3 volt. This indicates a concern is present.
Action	Go to the <i>Integrated Pressure Temperature Sensor (IPTS) Electrical Check</i> procedure under <i>Diagnostic Tests and Procedures — LPA-Fueled Vehicles</i> .

P0193 — Fuel Pressure Sensor A Circuit High

Description	The smart relay module (SRM) reads the integrated pressure temperature sensor (IPTS) and passes the voltage reading over the controller area network (CAN) bus to the powertrain control module (PCM). The PCM monitors the voltage as if the sensor were plugged into the vehicle.
--------------------	---

717



ROUSH CleanTech Blue Bird Vision Liquid Propane Autogas (LPA) Service Manual

Possible Causes	<ul style="list-style-type: none"> • CAN bus fault between the SRM and PCM • Wiring fault between IPTS and PCM • IPTS fuel rail pressure (FRP) signal short to signal return (SIG RTN) or power ground (PWR GND) • Damaged IPTS (or FRP) • IPTS failure • SRM failure
Symptom	—
Diagnostic Aid	Verify the FRP parameter ID (PID) value to determine open or short.
Action	Go to the <i>Integrated Pressure Temperature Sensor (IPTS) Electrical Check</i> procedure under <i>Diagnostic Tests and Procedures — LPA-Fueled Vehicles</i> .

Fuel Level Sensor (FLS)

P0460 — Fuel Level Sensor A Circuit

Description	Refer to the <i>Ford Powertrain Control/Emissions Diagnosis Service Manual</i> for more descriptive information.
Possible Causes	Refer to the Ford service manual. Causes are the same except that communication is between the sender and the smart relay module (SRM) and not the instrument cluster (IC).
Symptom	—
Diagnostic Aid	The SRM reads fuel level sender input and broadcasts it to the IC and PCM.
Action	Go to the <i>Fuel Level Indication System Check</i> procedure under <i>Diagnostic Tests and Procedures — LPA-Fueled Vehicles</i> .

P0461 — Fuel Level Sensor A Circuit Range/Performance

Description	Refer to the <i>Ford Powertrain Control/Emissions Diagnosis Service Manual</i> for more descriptive information.
Possible Causes	Refer to the Ford service manual. Causes are the same except that communication is between the sender and the smart relay module (SRM) and not the instrument cluster (IC).
Symptom	—
Diagnostic Aid	The SRM reads fuel level sender input and broadcasts it to the IC and PCM.
Action	Go to the <i>Fuel Level Indication System Check</i> procedure under <i>Diagnostic Tests and Procedures — LPA-Fueled Vehicles</i> .

718





BLUE BIRD

ROUSH
 CLEANTECH

**ROUSH CleanTech Blue Bird Vision Liquid Propane Autogas (LPA)
 Service Manual**
P0462 — Fuel Level Sensor A Circuit Low

Description	Refer to the <i>Ford Powertrain Control/Emissions Diagnosis Service Manual</i> for more descriptive information.
Possible Causes	Refer to the Ford service manual. Causes are the same except that communication is between the sender and the smart relay module (SRM) and not the instrument cluster (IC).
Symptom	—
Diagnostic Aid	The SRM reads fuel level sender input and broadcasts it to the IC and PCM.
Action	Go to the <i>Fuel Level Indication System Check</i> procedure under <i>Diagnostic Tests and Procedures — LPA-Fueled Vehicles</i> .

Other

All diagnostic trouble codes (DTCs) known to be affected by the liquid propane autogas system (LPA) are covered in this document. For all other DTCs, refer to the *Ford Powertrain Control/Emissions Diagnosis Service Manual* at www.motorcraft.com (2012 F-650 H561).



DIAGNOSTIC TESTS AND PROCEDURES — LPA-FUELED VEHICLES

General Information

Measuring Fuel Rail and Tank Pressure

Expected Fuel Tank Pressure

Fuel tank pressure can be measured two ways:

Method 1 — Install a 0–500 psi gauge on the bleeder valve.

Method 2 — Measure fuel rail pressure within one hour of vehicle shutdown.

On a tank at ambient temperature conditions, the following pressures can be expected:

Temperature (°F)	Pressure (psi)		
	Min.	Nominal	Max.
0	15	25	35
5	19	29	39
10	23	33	43
15	28	38	48
20	33	43	53
25	38	48	58
30	43	53	63
35	49	59	69
40	55	65	75
45	62	72	82
50	69	79	89
55	77	87	97
60	84	94	104
65	93	103	113
70	102	112	122
75	111	121	131
80	121	131	141
85	131	141	151
90	142	152	162
95	153	163	173
100	165	175	185
105	178	188	198
110	191	201	211
115	205	215	225
120	219	229	239

NOTE

On vehicles that have been operated for extended periods of time, the tank can be much warmer and higher pressures are to be expected.

Expected Fuel Rail Pressure

Under normal operating conditions, the fuel pump has two operating speeds. The pump operates in low speed mode at idle and during moderate fuel flow/part throttle driving.

Once a fuel demand threshold is met, typically during wide open throttle (WOT) operation, the pump is switched to high speed. The pump is also operated at high speed during the pre-start flush sequence.

The fuel pressure controls are designed to keep the rails at a certain pressure over tank pressure, therefore, it is important to measure tank pressure prior to collecting fuel rail pressure data. For example, if the fuel tank is at 150 psi and pressure in the rail is measured at 200 psi, the rail is running at 50 psi above tank pressure.

Condition	Pump Speed	Pressure Over Tank
Engine Off	Off	<10
Idle	Low	>30
Part Throttle	Low	<25
Part Throttle	High	>25
WOT	High	>25

NOTE

Under extreme operating conditions, there is a third pump mode. In the event that the fuel system has degraded and the sensor detects vapor, or if the fuel rail pressure is approaching the limit of the fuel system, the pump runs in a variable speed mode, controlling to a target pressure. In this mode there is no predicted rise over tank pressure. The fuel pump will adjust the pressure to maintain a required operating pressure. This condition will likely result in a P116E or P0148 code.

720





BLUE BIRD

ROUSH
 CLEANTECH

**ROUSH CleanTech Blue Bird Vision Liquid Propane Autogas (LPA)
 Service Manual**
No Fill

Step	Procedure	Action
1	Inspect vehicle to check for kinked fill lines. Are lines kinked?	Yes — Replace kinked lines. No — Go to Step 2.
2	Determine the location of the overfill prevention device (OPD). Is the OPD located in the end cap of the fuel tank?	Yes — Go to Step 3. No — Go to Step 6.
3	Check the fuel gauge in the instrument cluster. Is the gauge indicating less than 1/4 full?	Yes — Go to Step 4. No — Go to Step 6.
4	Check to see if the OPD is being activated. <div style="border: 1px solid black; padding: 5px; text-align: center; margin: 10px 0;">NOTE</div> Fuel splashing off the sides of the empty tank could be activating the OPD float and shutting off the fuel fill line. <ul style="list-style-type: none"> a. Crack the fuel fill line at the fill valve or the fuel fill filter to relieve any pressure in the fill line and release the OPD valve. Retighten the fill line. b. Install a fuel fill pressure tester on the fill valve and close the ball valve. c. Connect the fuel dispensing nozzle to the pressure tester and turn on the pump. Slightly open the ball valve to slowly add approximately 10 gallons of fuel. d. Did the tank fill? 	Yes — Go to Step 5. No — Go to Step 6.
5	Remove the fuel fill pressure tester and attempt to fill the vehicle fuel tank to full 80% capacity. Does the vehicle fuel tank fill to capacity?	Yes — Diagnostic is complete. No — Go to Step 6.
6	Check the fuel gauge in the instrument cluster. Is the gauge indicating more than 1/2 full?	Yes — Go to Step 7. No — Go to Step 11.
7	Reverse direction of vehicle at the pump and try to fill the vehicle. Does the vehicle fuel tank fill?	Yes — Vehicle not on level ground. Diagnostic is complete. No — Drive vehicle until fuel gauge indicates less than 1/2 full and go to Step 8.
8	Attempt to fill the vehicle fuel tank. Does the fuel tank fill?	Yes — Go to Step 9. No — Go to Step 11.
9	Open bleeder valve. Does liquid fuel vent?	Yes — Go to Step 10. No — Go to Step 12.
10	Check fuel gauge. Does fuel gauge read full?	Yes — Diagnostic complete. No — Go to the <i>Fuel Level Indicator Check</i> procedure.

721



Step	Procedure	Action
11	<p>Check for sufficient fill station pressure.</p> <p>a. Connect pressure gauge service tool to the fuel tank bleeder valve and record pressure.</p> <p>b. Using a fuel fill pressure tester installed on the fill valve, attempt to fill the vehicle.</p> <p>c. With the dispensing pump on and dispensing nozzle open, measure and record fill station pump pressure.</p> <p>d. Is fill station pump pressure at least 20 psi greater than tank pressure?</p>	<p>Yes — Go to Step 12.</p> <p>No — Fill station may not be providing enough pressure to fill. Go to Step 19.</p>
12	<p>Check body side fuel fill valve; it may be stuck closed.</p> <p>a. Crack fuel fill line connection to the body-side fill valve or fuel line filter to relieve any pressure in the fill line.</p> <p>b. Attempt to push open the piston in the fill valve to determine if it is stuck closed.</p> <p>c. Is the fill valve piston stuck closed?</p>	<p>Yes — Replace body-side fill valve and go to Step 13.</p> <p>No — Replace filter in the fuel fill line and go to Step 15.</p>
13	<p>Attempt to fill the vehicle fuel tank.</p> <p>Does the fuel tank fill?</p>	<p>Yes — Diagnostic is complete.</p> <p>No — Go to Step 14.</p>
14	<p>Replace the filter in the fuel fill line and then attempt to fill the vehicle fuel tank.</p> <p>Does the vehicle fuel tank fill?</p>	<p>Yes — Diagnostic is complete.</p> <p>No — Go to Step 16.</p>
15	<p>Attempt to fill the vehicle fuel tank.</p> <p>Does the fuel tank fill?</p>	<p>Yes — Diagnostic is complete.</p> <p>No — Go to Step 16.</p>
16	<p>Replace the OPD valve in the vehicle fuel tank.</p> <p>Is the OPD valve located in the end cap of the fuel tank?</p>	<p>Yes — Go to Step 17.</p> <p>No — Go to Step 18.</p>

722





BLUE BIRD

ROUSH
CLEANTECH

**ROUSH CleanTech Blue Bird Vision Liquid Propane Autogas (LPA)
Service Manual**

Step	Procedure	Action
17	<p>Attempt to fill the vehicle fuel tank as follows:</p> <div style="border: 1px solid black; padding: 5px; text-align: center; margin: 10px 0;"> <p>NOTE</p> </div> <p>When filling a new tank that has the OPD valve mounted in the end cap of the fuel tank, fuel splashing off the sides of the empty tank could be activating the OPD float and shutting off the fuel fill line.</p> <ol style="list-style-type: none"> a. Install a fuel fill pressure tester on the fill valve and close the ball valve. b. Connect the fuel dispensing nozzle to the pressure tester and turn on the pump. Slightly open the ball valve to slowly add approximately 10 gallons of fuel. c. Remove the fuel fill pressure tester. d. Attempt to fill the remaining tank volume (to 80% full capacity) at full flow from the dispensing nozzle. e. Did the tank fill? 	<p>Yes — Diagnostic is complete.</p> <p>No — Call ROUSH CleanTech Customer Service at 800-597-6874.</p>
18	<p>Attempt to fill the vehicle fuel tank.</p> <p>Does the fuel tank fill?</p>	<p>Yes — Diagnostic is complete.</p> <p>No — Call ROUSH CleanTech Customer Service at 800-597-6874.</p>
19	<p>Fill station is not providing enough pressure to fill.</p> <ol style="list-style-type: none"> a. Using the tables provided at the front of this section, determine expected propane tank pressure based on ambient temperature. b. Is the vehicle fuel tank pressure greater than 20 psi over the nominal expected pressure? 	<p>Yes — Go to Step 20.</p> <p>No — Locate a dispensing facility with pump output capacity in excess of 100 psi (preferably an Auto Gas-type facility). Then, go to Step 12.</p>
20	<p>Vehicle fuel tank is at a higher pressure.</p> <ol style="list-style-type: none"> a. Higher pressure is likely caused by heavy vehicle usage heating the fuel. b. Allow the vehicle (fuel tank) to cool and then recheck pressure in the fuel tank. 	<p>When tank pressure is within 10 psi of expected tank pressure, go to Step 21.</p>





Step	Procedure	Action
21	<p>Measure and compare vehicle fuel tank and fill station pressures.</p> <p>a. Connect a pressure gauge service tool to the fuel tank bleeder valve and record fuel tank pressure.</p> <p>b. Using a fuel fill pressure tester installed on the fill valve, attempt to fill the vehicle.</p> <p>c. With the dispensing pump on and dispensing nozzle open, measure and record fill station pump pressure.</p> <p>d. Is fill station pump pressure at least 20 psi greater than fuel tank pressure?</p>	<p>Yes — Go to Step 22.</p> <p>No — Fill station is not providing enough pressure to fill vehicle tank. Go to Step 22. Locate a dispensing facility with pump output capacity in excess of 100 psi (preferably an Auto Gas-type facility).</p>
22	<p>Attempt to fill the vehicle fuel tank.</p> <p>Does the fuel tank fill?</p>	<p>Yes — Diagnostic is complete.</p> <p>No — Go to Step 12.</p>

Slow Fill

Step	Procedure	Action
1	<p>Inspect vehicle to check for kinked fill lines.</p> <p>Are lines kinked?</p>	<p>Yes — Replace kinked lines.</p> <p>No — Go to Step 2.</p>
2	<p>Determine flow rate at which the vehicle fuel system fills.</p> <p>a. Time the fill station pump for 10 seconds and record the number of gallons dispensed.</p> <p>b. Multiply the gallons dispensed by six to determine the flow rate in gallons per minute.</p> <p>c. Is the fill station pump flow rate at least 6 gallons per minute?</p>	<p>Yes — System fill rate is OK; diagnostic is complete.</p> <p>No — Fill station is not providing enough pressure to fill vehicle tank. Go to Step 3.</p>
3	<p>Measure and compare vehicle fuel tank and fill station pressures.</p> <p>a. Connect a pressure gauge service tool to the fuel tank bleeder valve and record fuel tank pressure.</p> <p>b. Using a fuel fill pressure tester installed on the fill valve, attempt to fill the vehicle.</p> <p>c. With the dispensing pump on and dispensing nozzle open, measure and record fill station pump pressure.</p> <p>d. Is fill station pump pressure at least 50 psi greater than fuel tank pressure?</p>	<p>Yes — Go to Step 4.</p> <p>No — Fill station is not providing enough pressure to fill vehicle tank. Go to Step 11.</p>





BLUE BIRD

ROUSH
 CLEANTECH

**ROUSH CleanTech Blue Bird Vision Liquid Propane Autogas (LPA)
 Service Manual**

Step	Procedure	Action
4	Check fuel fill valve; it may not be opening completely. <ol style="list-style-type: none"> Crack fuel fill line connection to the fill valve or fuel fill line filter to relieve any pressure in the fill line. Attempt to push open the piston in the fill valve to determine if it is opening completely. Piston should travel 1/4 inch. Is the fill valve piston opening completely? 	Yes — Replace the filter in the fuel fill line and then go to Step 7. No — Replace the fuel fill valve and then go to Step 5.
5	Attempt to fill the vehicle fuel tank. Does the fuel tank fill at greater than 6 gallons per minute?	Yes — Diagnostic is complete. No — Go to Step 6.
6	Replace the filter in the fuel fill line. Does the vehicle fuel tank fill at greater than 6 gallons per minute?	Yes — Diagnostic is complete. No — Go to Step 7.
7	Attempt to fill the vehicle fuel tank. Does the fuel tank fill at greater than 6 gallons per minute?	Yes — Diagnostic is complete. No — Go to Step 8.
8	Replace the overfill protection device (OPD) valve in the vehicle fuel tank. Is the OPD valve located in the end cap of the fuel tank?	Yes — Go to Step 9. No — Go to Step 10.
9	Attempt to fill the vehicle fuel tank as follows: <div style="border: 1px solid black; padding: 5px; text-align: center; margin: 10px 0;"> NOTE </div> When filling a new tank that has the OPD valve mounted in the end cap, fuel splashing off the sides of the empty tank could be activating the OPD float and shutting off the fuel fill line. <ol style="list-style-type: none"> Install a fuel fill pressure tester on the fill valve and close the ball valve. Connect the fuel dispensing nozzle to the pressure tester and turn on the pump. Slightly open the ball valve to slowly add approximately 10 gallons of fuel. Remove the fuel fill pressure tester. Attempt to fill the remaining tank volume (to 80% full capacity) at full flow from the dispensing nozzle. Did the tank fill? 	Yes — Diagnostic is complete. No — Call ROUSH CleanTech Customer Service at 800-597-6874.
10	Attempt to fill the vehicle fuel tank. Does the fuel tank fill at greater than 6 gallons per minute?	Yes — Diagnostic is complete. No — Call ROUSH CleanTech Customer Service at 800-597-6874.

725



ROUSH CleanTech Blue Bird Vision Liquid Propane Autogas (LPA) Service Manual

Step	Procedure	Action
11	<p>Fill station is not providing enough pressure to fill.</p> <p>a. Using the tables provided at the front of this section, determine expected propane tank pressure based on ambient temperature.</p> <p>b. Is the vehicle fuel tank pressure greater than 20 psi over the nominal expected pressure?</p>	<p>Yes — Go to Step 12.</p> <p>No — Locate a dispensing facility with pump output capacity in excess of 100 psi (preferably an Auto Gas-type facility). Then, go to Step 2.</p>
12	<p>Vehicle fuel tank is at a higher pressure.</p> <p>a. Higher pressure is likely caused by heavy vehicle usage heating the fuel.</p> <p>b. Allow the vehicle (fuel tank) to cool and then recheck pressure in the fuel tank.</p>	<p>When tank pressure is within 10 psi of expected tank pressure, go to Step 13.</p>
13	<p>Measure and compare vehicle fuel tank and fill station pressures.</p> <p>a. Connect a pressure gauge service tool to the fuel tank bleeder valve and record fuel tank pressure.</p> <p>b. Using a fuel fill pressure tester installed on the fuel fill valve, attempt to fill the vehicle.</p> <p>c. With the dispensing pump on and dispensing nozzle open, measure and record fill station pump pressure.</p> <p>d. Is fill station pump pressure at least 50 psi greater than fuel tank pressure?</p>	<p>Yes — Go to Step 14.</p> <p>No — Fill station is not providing enough pressure to fill vehicle tank. Go to Step 14. Locate a dispensing facility with pump output capacity in excess of 100 psi (preferably an Auto Gas-type facility).</p>
14	<p>Attempt to fill the vehicle fuel tank.</p> <p>Does the fuel tank fill at greater than 6 gallons per minute?</p>	<p>Yes — Diagnostic is complete.</p> <p>No — Go to Step 4.</p>

Over Fill

Step	Procedure	Action
1	<p>Suspect overfill because fuel fill volumes achieved during refueling exceed the rated fuel capacity or excessive vehicle range between refueling.</p> <p>a. Check the fuel gauge.</p> <p>b. Is the gauge reading below 1/2 tank?</p>	<p>Yes — Go to Step 2.</p> <p>No — Drive vehicle until gauge reads below 1/4 tank.</p>
2	<p>Open bleeder valve located on the tank or remotely mounted on the vehicle.</p> <p>a. Listen at valve to verify propane vapor is venting.</p> <p>b. Is propane vapor venting?</p>	<p>Yes — Go to Step 3.</p> <p>No — Bleeder valve is not functioning properly. Replace the valve.</p>

726





BLUE BIRD

ROUSH
CLEANTECH

**ROUSH CleanTech Blue Bird Vision Liquid Propane Autogas (LPA)
Service Manual**

Step	Procedure	Action
3	<p>Park the vehicle at the refueling station.</p> <p>a. Check to determine if the vehicle is level using the vehicle frame as reference.</p> <p>b. Does the vehicle set level?</p>	<p>Yes — Go to Step 4.</p> <p>No — Using a jack, raise the vehicle to obtain a level condition. Then, go to Step 4.</p>
4	<p>Locate the American Society of Mechanical Engineers (ASME) inspection plate on the fuel tank.</p> <p>a. Note the tank water capacity listed on the plate.</p> <p>b. Multiply the listed capacity by 0.05 (5%) and record the value.</p>	<p>With the value recorded, go to Step 5.</p>
5	<p>Refuel the vehicle as follows:</p> <div style="border: 1px solid black; padding: 5px; text-align: center; margin: 10px 0;"> <p>NOTE</p> </div> <p>If the key is on during refueling, it will take the fuel level gauge in the instrument cluster longer to register full.</p> <p>a. Verify that the ignition is in the off position.</p> <p>b. Install the fuel fill pressure tester on the fill valve and close the ball valve.</p> <p>c. Connect the fuel dispensing nozzle to the pressure tester. Verify that the bleeder valve is open.</p> <p>d. With the bleeder valve open, turn on the pump. Open the ball valve slightly to very slowly refuel the vehicle.</p> <p>e. While refueling, observe the bleeder valve for fuel discharge.</p> <p>f. Stop filling when a solid stream of liquid fuel flows from the bleeder valve or the dispensing pump stops automatically.</p> <p>g. Did a solid stream of liquid flow from the bleeder valve?</p>	<p>Yes — Record the volume of fuel dispensed and then go to Step 6.</p> <p>No — Go to Step 7.</p>
6	<p>Resume filling until the dispensing pump stops automatically.</p> <p>a. Record the total volume of fuel dispensed and subtract the amount from the volume recorded in Step 5.</p> <p>b. Is the additional amount of fuel dispensed less than 5% of the tank water capacity determined in Step 4?</p>	<p>Yes — Tank does not overflow. Diagnostic is complete.</p> <p>No — Tank is overflowing. Replace the overflow protection device (OPD) fill valve in the fuel tank; then, go to Step 8.</p>
7	<p>The dispensing pump stopped automatically and a liquid fuel stream was not observed flowing from bleeder valve.</p>	<p>Tank does not overflow. Diagnostic is complete.</p>





ROUSH CleanTech Blue Bird Vision Liquid Propane Autogas (LPA) Service Manual

Step	Procedure	Action
8		<p>Yes — Record the volume of fuel dispensed and then go to Step 9.</p> <p>No — Go to Step 7.</p>
9		<p>Yes — Tank does not overflow. Diagnostic is complete.</p> <p>No — Tank is overflowing. Replace the fuel tank assembly.</p>

728

Engine Does Not Crank

Step	Procedure	Action
1	Is battery voltage above 10 volts?	<p>Yes — Go to Step 2.</p> <p>No — Determine cause of low battery voltage.</p>
2	<p>Verify that the smart relay module (SRM) has communication.</p> <p>Can fuel rail pressure and temperature be read with a scan tool?</p>	<p>Yes — Go to Step 3.</p> <p>No — Go to <i>Smart Relay Module (SRM) Electrical Test</i> procedure.</p>
3	<p>Refer to the <i>Ford Powertrain Control/Emission Diagnosis Service Manual</i>.</p> <p>Is the problem corrected?</p>	<p>Yes — Diagnostic is complete.</p> <p>No — Call ROUSH CleanTech Customer Service at 800-597-6874.</p>





BLUE BIRD

ROUSH
 CLEANTECH

**ROUSH CleanTech Blue Bird Vision Liquid Propane Autogas (LPA)
 Service Manual**
Engine Cranks, No Start

Step	Procedure	Action
1	Verify the following: <ol style="list-style-type: none"> Is there fuel in the tank of at least 1/8 tank or more? (add fuel if necessary). Is the tank supply manual shut-off valve fully open? Is battery voltage above 10 volts? 	Yes — Go to Step 2. No — Correct fault and retry.
2	Check for diagnostic trouble codes (DTC). Are any codes present?	Yes — Go to Step 3. No — Go to Step 4.
3	Is the DTC identified on the ROUSH LPA DTC list?	Yes — Refer to <i>Diagnostic Trouble Codes — LPA-Fueled Vehicles</i> . No — Refer to Ford service manual DTC chart.
4	Check fuel pressure. <ol style="list-style-type: none"> Measure and record fuel rail and fuel tank pressure, key on, engine off (KOEO). While monitoring fuel pressure, attempt to start engine. Record the highest pressure observed. Does fuel pressure rise 25 psi before engine crank? 	Yes — Go to Step 11. No — Go to Step 5.
5	Check fuel pump operation. <ol style="list-style-type: none"> Turn the ignition switch to start and wait for the engine to crank. Using a current clamp, check current draw to determine if fuel pumps run when engine cranks. When measuring fuel pump current a minimum of 2 amps should be recorded. Do fuel pumps draw current when engine cranks? 	Yes — Go to Step 6. No — Check OEM fuel pump (FP) fuse and replace fuse, if necessary. If OK, go to Step 10.
6	Check excess flow valve (XFV). <ol style="list-style-type: none"> Turn off engine. Wait 1 minute and then restart engine. Measure and record fuel pressure, using a scan tool, at integrated pressure temperature sensor (IPTS). Is problem resolved? 	Yes — Go to Step 11. No — Go to Step 7.
7	Check Blue Bird fuel pump (FP) fuse. Is fuse intact and OK?	Yes — Go to Step 8. No — Determine the cause of the short and repair; replace the fuse. Diagnostic is complete.

729



ROUSH CleanTech Blue Bird Vision Liquid Propane Autogas (LPA) Service Manual

730

Step	Procedure	Action
8	<p>Check the tank solenoid (TS) and supply solenoid (SS) fuses. Refer to the <i>Blue Bird Service Manual</i>.</p> <p>a. Locate the TS fuse and check its condition. b. Locate the SS fuse and check its condition. c. Are the fuses blown?</p>	<p>Yes — Determine the cause of the short and repair; replace the fuse. No — Go to Step 9.</p>
9	<p>Verify that there is power and proper grounding in the tank solenoid (TS) and supply solenoid (SS) wiring circuits. Refer to the <i>Blue Bird Service Manual</i>.</p> <p>a. Check for +12 volts at the TS and SS connectors. See the <i>Tank Solenoid Electrical Check</i> procedure. b. Is +12 volts present at the TS connector? c. Is +12 volts present at the SS connector?</p>	<p>Yes — Voltage present at SS, replace FRPCM. Voltage present at TS, replace fuel supply valve assembly. No — Check for an open(s) in the wiring circuits and repair. Diagnostic is complete.</p>
10	<p>Verify that there is power and proper grounding in the wiring circuit to the tank. Refer to the <i>Blue Bird Service Manual</i>.</p> <p>a. Check for +12 volts at the fuel pump 1 (FP1) and fuel pump 2 (FP2) connectors. See the <i>Fuel Pump Electrical Check</i> procedure. b. Is +12 volts present at the FP1 connector? c. Is +12 volts present at the FP2 connector?</p>	<p>Yes — Go to Step 11. No — Check for an open(s) in the wiring circuits and repair.</p>
11	<p>Integrated Pressure Temperature Sensor (IPTS) Rationality</p> <p>Does temperature and pressure make sense to verification procedure?</p>	<p>Yes — Refer to the <i>Integrated Pressure Temperature Sensor (IPTS) Electrical Check</i>. No — Verify that wiring in circuit is OK. See the <i>Integrated Pressure Temperature Sensor (IPTS) Electrical Check</i> procedure. If not, repair wiring. If OK, replace sensor.</p>
12	<p>Inspect the tank pass-through harness.</p> <p>a. Drain the propane from the fuel tank. Refer to the <i>Fuel Tank Draining Procedure</i> in the appropriate ROUSH CleanTech Service Manual for more information. b. Remove tank service cover. c. Check for open or short circuits on tank pass-through harness. d. Is a wiring problem present?</p>	<p>Yes — Replace harness. No — Go to Step 13.</p>
13	<p>Check fuel hoses and quick-connect fittings.</p> <p>Are in-tank fuel hoses and quick-connect fittings connected and in good condition?</p>	<p>Yes — Replace fuel pump assembly. No — Replace hose assemblies as needed.</p>





BLUE BIRD

ROUSH
 CLEANTECH

**ROUSH CleanTech Blue Bird Vision Liquid Propane Autogas (LPA)
 Service Manual**
Engine Stumble, Stall, Rough Idle

Step	Procedure	Action
1	Verify the following: <ol style="list-style-type: none"> Is there fuel in the tank of at least 1/8 tank or more? (Add fuel if necessary.) Is the tank supply manual shut-off valve fully open? Is battery voltage above 11 volts with engine running? 	Yes — Go to Step 2. No — Correct the fault and retry.
2	Check for diagnostic trouble codes (DTCs). Are any codes present?	Yes — Go to Step 3. No — Go to Step 4.
3	Identify the DTC. <ol style="list-style-type: none"> Is the DTC covered in the ROUSH CleanTech DTC listing for LPA-fueled vehicles? Correct all DTCs before continuing. 	Yes — Refer to ROUSH CleanTech DTC procedure. No — Refer to the <i>Ford Powertrain Control/Emissions Diagnosis Service Manual</i> at www.motorcraft.com (F-650 H561).
4	Does the problem occur only after cold start?	Yes — Go to Step 6. No — Go to Step 5.
5	Determine fuel pressure. <ol style="list-style-type: none"> Measure tank pressure with key on and engine off (KOEO). Measure fuel rail pressure with key on and engine running (KOER). Subtract the KOEO pressure from the KOER pressure to obtain the difference. Compare to the chart in Expected Fuel Rail Pressure. Is the resulting fuel pressure reading within the expected range? 	Yes — Go to Step 7. No — Go to Step 6.
6	Determine if the excess flow valve (XFV) is tripped. <ol style="list-style-type: none"> Turn off the engine. Wait one minute and then restart the engine. Is the fault condition resolved? 	Yes — Go to <i>Excess Flow Valve (XFV) Check</i> procedure. No — Go to Step 7.
7	Determine fuel pressure at time of fault. <ol style="list-style-type: none"> While driving the vehicle, determine and record the fuel pressure during stumble. Does the pressure drop more than 10 psi during stumble? 	Yes — Go to Step 8. No — Go to Step 14.

731



ROUSH CleanTech Blue Bird Vision Liquid Propane Autogas (LPA) Service Manual

Step	Procedure	Action
8	<p>Check fuel pump operation.</p> <p>a. Turn the ignition switch to start and wait for engine to crank.</p> <p>b. Using a current clamp, check current draw to determine if fuel pumps run when engine cranks. When measuring fuel pump current a minimum of 2 amps should be recorded. Do fuel pumps run?</p>	<p>Yes — Go to Step 5.</p> <p>No — Check OEM fuel pump (FP) fuse and replace fuse if necessary. If OK, go to Step 10.</p>
9	<p>Check Blue Bird fuel pump fuse. Refer to the Blue Bird Service Manual.</p> <p>Is fuel pump fuse intact and OK?</p>	<p>Yes — Go to Step 6.</p> <p>No — Repair short and replace fuse.</p>
10	<p>Check tank solenoid (TS) and supply solenoid (SS) fuses.</p> <p>a. Locate the TS and SS fuses.</p> <p>b. Are the fuses blown?</p>	<p>Yes — Find and repair the short; replace the fuse.</p> <p>No — Go to Step 11.</p>
11	<p>Verify that there is power and grounding in the tank solenoid (TS) and supply solenoid (SS) wiring circuits. Refer to the Blue Bird Electrical Manual.</p> <p>a. Check for +12 volts at the TS and SS connectors. See the Tank Solenoid Electrical Check procedure.</p> <p>b. Is +12 volts present at the TS connector? c. Is +12 volts present at the SS connector?</p>	<p>Yes — Voltage present at SS, replace FRPCM. Voltage present at TS, replace fuel supply valve assembly.</p> <p>No — Check for an open/short in the wiring circuit and repair.</p>
12	<p>Verify that there is power and proper grounding in the wiring circuit to the tank. Refer to the Blue Bird Electrical Manual.</p> <p>a. Check for +12 volts at the fuel pump 1 (FP1) and fuel pump 2 (FP2) connectors. See the Fuel Rail Pressure Control Module (FRPCM) Electrical Check procedure.</p> <p>b. Is +12 volts present at the FP1 connector?</p> <p>c. Is +12 volts present at the FP2 connector?</p>	<p>Yes — Go to Step 13.</p> <p>No — Check for an open/short in the wiring circuit and repair.</p>
13	<p>Inspect the tank pass-through harness.</p> <p>a. Drain the propane from the fuel tank. See the Fuel Tank Draining Procedure in the appropriate ROUSH CleanTech Service Manual for more information.</p> <p>b. Remove tank service cover.</p> <p>c. Check for open or short circuits on tank pass-through harness.</p> <p>d. Is a wiring problem present?</p>	<p>Yes — Replace harness.</p> <p>No — Go to Step 14.</p>
14	<p>Check fuel hoses and quick-connect fittings.</p> <p>Are in-tank fuel hoses and quick-connect fittings connected and in good condition?</p>	<p>Yes — Replace fuel pump assembly.</p> <p>No — Replace hose assemblies as needed.</p>

732





BLUE BIRD

ROUSH
 CLEANTECH

**ROUSH CleanTech Blue Bird Vision Liquid Propane Autogas (LPA)
 Service Manual**

Step	Procedure	Action
15	Integrated Pressure Temperature Sensor (IPTS) Rationality Does temperature and pressure make sense to verification? See the <i>Integrated Pressure Temperature Sensor (IPTS) Electrical Check</i> procedure.	Yes — Go to Step 16. No — Verify that wiring in circuit is OK. If not, repair wiring. If OK, replace sensor.
16	Refer to the <i>Ford Powertrain Control/Emissions Diagnosis Service Manual</i> at www.motorcraft.com (2012 F-650 H561).	—

Excess Flow Valve (XFV) Check

The excess flow valve (XFV) is designed to restrict fuel exiting the tank if the pump is energized while the fuel lines are not connected to the fuel tank. Under normal circumstances, the XFV should not trip. The XFV will reset itself after the fuel pumps have been off for about one minute.

It is common to trip the XFV after the fuel lines have been serviced and contain no pressure. If the XFV trips, turn the vehicle off, wait one minute, and restart. This may take more than one attempt.

If the fuel lines have not been serviced recently and the problem persists, there may be a leak in the supply side fuel line. If the problem is only present after the vehicle has been sitting for a length of time, but not present during a short soak, or there is a propane odor when the vehicle is running, see the *Fuel Line Leak Detection* procedure.

Step	Procedure	Action
1	Verify fuel supply line pressure prior to cranking engine. <ol style="list-style-type: none"> Read fuel rail pressure and tank pressure. Energize bleed solenoid until rail pressure is at least 50 psi below tank pressure. If rail is bled, skip to Step D. Let pressure stabilize for 1 minute. Open the supply solenoid. Read fuel rail pressure and tank pressure. Does fuel rail pressure jump to tank pressure? 	Yes — Check is OK. No — Repair the leak in the fuel supply line.

Maximum Pressure Check

The LPA system operates over a wide range of pressures depending on ambient temperature, driving mode, etc. When the vehicle is subjected to a severe drive cycle in high ambient temperatures, the fuel rail pressure can rise to the limit of the injectors capabilities. This limit is a function of injector voltage and fuel rail pressure. The PCM protects for this condition by reducing the fuel pump speed when the condition is sensed, however, there still may be drive concerns. When the PCM starts controlling the fuel pump a P116E code is set. While this condition can occur in a normally functioning vehicle, it can also be exacerbated by several factors. If the fuel tank was not properly bled during the first fill trapped air in the vapor space can increase tank pressure. In this condition there is often only a faint smell of propane when the bleeder valve is opened. The tank should be vented until there is a strong propane odor coming from the bleeder valve. The tank pressure should be confirmed against the expected pressure. Another factor that can lead to a premature maximum pressure condition is debris in the return orifice of the FRPCM. The fuel rail pressure is set by a 0.110" orifice in the return circuit. If debris becomes lodged in this orifice, flow back to the tank will be restricted and the fuel rail pressure will rise.

Allow the fuel tank to cool to ambient temperature before performing the following procedure.



ROUSH CleanTech Blue Bird Vision Liquid Propane Autogas (LPA) Service Manual

Step	Procedure	Action
1	<p>Measure tank pressure and tank surface temperature.</p> <p>Is tank pressure more than 15 psi over expected tank pressure?</p>	<p>Yes — Vent the tank until pressure is within the expected range.</p> <p>No — Go to Step 2.</p>
2	<p>Start the engine and measure fuel rail pressure while engine is idling.</p> <p>Is fuel rail pressure more than 20 psi over expected rail pressure?</p>	<p>Yes — Check for debris in the fuel return circuit.</p> <p>No — Vehicle is working properly; inform and explain operating characteristics to customer.</p>

Supply Solenoid (SS) Check

Step	Procedure	Action
1	<p>Verify the following:</p> <ul style="list-style-type: none"> a. Is there fuel in the tank of at least 1/8 tank or more? (Add fuel if necessary.) b. Is the tank supply manual shut-off valve fully open? c. Is battery voltage above 10 volts? 	<p>Yes — Go to Step 2.</p> <p>No — Correct fault and retry.</p>
2	<p>Check for diagnostic trouble codes (DTC).</p> <p>Are any codes present?</p>	<p>Yes — Go to Step 3.</p> <p>No — Go to Step 4.</p>
3	<p>Is the DTC identified on the ROUSH liquid propane autogas (LPA) DTC list?</p>	<p>Yes — Refer to <i>Diagnostic Trouble Codes (DTC) — LPA-Fueled Vehicles</i>.</p> <p>No — Refer to Ford service manual DTC chart.</p>
4	<p>Check fuel pressure.</p> <ul style="list-style-type: none"> a. Measure and record fuel rail pressure and fuel tank pressure at key on, engine off (KOEO). b. While monitoring fuel pressure, attempt to start engine. c. Record the highest pressure observed. d. Does fuel pressure rise 20 psi before engine crank? 	<p>Yes — Go to Step 9.</p> <p>No — Go to Step 5.</p>
5	<p>Check for fuel pump operation.</p> <ul style="list-style-type: none"> a. Turn ignition switch to start and wait for engine to crank. b. Using a current clamp, check current draw to determine if fuel pumps run when engine cranks. When measuring fuel pump current a minimum of 2 amps should be recorded. Do fuel pumps run? 	<p>Yes — Go to Step 6.</p> <p>No — Check OEM fuel pump (FP) fuse and replace fuse if necessary. If OK, go to Step 10.</p>

734





BLUE BIRD

ROUSH
 CLEANTECH

**ROUSH CleanTech Blue Bird Vision Liquid Propane Autogas (LPA)
 Service Manual**

Step	Procedure	Action
6	Check excess flow valve (XFV). a. Turn off engine. b. Wait 1 minute and then restart engine. c. Measure and record fuel rail pressure and fuel tank pressure. d. Is problem resolved?	Yes — Go to Step 11. No — Go to Step 7.
7	Check Blue Bird fuel pump fuse. Refer to the Blue Bird Service Manual for fuse box and circuit information. Is fuse intact and OK?	Yes — Go to Step 8. No — Determine the cause of the short and repair; replace the fuse.
8	Check the tank solenoid (TS) and supply solenoid (SS) fuses. Refer to the Blue Bird Service Manual. a. Locate the TS fuse and check its condition. b. Locate the SS fuse and check its condition. c. Are the fuses blown?	Yes — Determine the cause of the short and repair; replace the fuse. No — Go to Step 9.
9	Verify that there is power and proper grounding in the tank solenoid (TS) and supply solenoid (SS) wiring circuits. a. Check for +12 volts at the TS and SS connectors. See the <i>Tank Solenoid Electrical Check</i> procedure. b. Is +12 volts present at the TS connector? c. Is +12 volts present at the SS connector?	Yes — Voltage present at SS, replace FRPCM. Voltage present at TS, replace fuel supply valve assembly. No — Check for an open/short in the wiring circuit and repair.
10	Verify that there is power and proper grounding in the wiring circuit to the tank. a. Check for +12 volts at the fuel pump 1 (FP1) and fuel pump 2 (FP2) connectors. See the <i>Fuel Rail Pressure Control Module (FRPCM) Electrical Check</i> procedure. b. Is +12 volts present at the FP1 connector? c. Is +12 volts present at the FP2 connector?	Yes — Refer to Engine Stumble, Stall, Rough Idle Step 12. No — Check for an open/short in the wiring circuit and repair.
11	Integrated Pressure Temperature Sensor (IPTS) Rationality Does temperature and pressure make sense to verification?	Yes — Go to Step 12. No — Verify that wiring in circuit is OK. See the <i>Integrated Pressure Temperature Sensor (IPTS) Electrical Check</i> procedure. If not, repair wiring. If OK, replace sensor.
12	Refer to Ford Powertrain Control/Emissions Diagnosis Service Manual at www.motorcraft.com (2012 F-650 H561).	—



Fuel System Fails to Bleed

Step	Procedure	Action
1	<p>Determine if fault condition repeats.</p> <ul style="list-style-type: none"> a. Start the engine and allow it to run for a few minutes. b. Turn off the engine and wait one minute. c. Measure and record the fuel rail pressure, fuel rail temperature and fuel tank pressure with the engine off (KOEO). d. Energize the bleed solenoid (see Manual Solenoid Activation Procedure). e. With the engine off, monitor fuel rail pressure for 15 minutes. f. Does fuel rail pressure drop more than 20 psi? 	<p>Yes — Go to Step 5. No — Go to Step 2.</p>
2	<p>Verify solenoid/restrictor function.</p> <ul style="list-style-type: none"> a. Start the engine and allow it to run for a few minutes. b. Turn off the engine. c. Disconnect the evaporative (EVAP) line from the fuel rail pressure control module (FRPCM) port. d. Energize the bleed solenoid. See the <i>Manual Solenoid Activation Procedure</i>. e. Is there propane flowing from the port? 	<p>Yes — Go to Step 4. No — Go to Step 3.</p>
3	<p>Verify that wiring is in good condition and functioning.</p> <ul style="list-style-type: none"> a. Perform wiring checks of the FRPCM harness. b. Is the wiring OK? 	<p>Yes — Bleed solenoid stuck closed or port restrictor is plugged. Replace the FRPCM. No — Repair wiring and repeat Step 1.</p>
4	<p>Check for a kinked EVAP line.</p> <ul style="list-style-type: none"> a. Inspect the EVAP line between the FRPCM and EVAP canister. b. Are there kinks in the line? 	<p>Yes — Replace the kinked EVAP line and then repeat Step 1. No — Go to Step 5.</p>

736





BLUE BIRD

ROUSH
 CLEANTECH

**ROUSH CleanTech Blue Bird Vision Liquid Propane Autogas (LPA)
 Service Manual**

Step	Procedure	Action
5	Check for leaks to the FRPCM. <ol style="list-style-type: none"> Start the engine and allow it to run for a few minutes. Turn off the engine and unplug the FRPCM. Measure and record fuel rail pressure. Bleed pressure from fuel rail until fuel pressure drops more than 50 psi. De-energize bleed solenoid. Let vehicle sit for 30 minutes. Measure fuel rail pressure and fuel tank pressure. Does fuel rail pressure rise more than 10 psi? 	Yes — FRPCM leaks at either supply solenoid or return check valve. Replace FRPCM. No — Potential intermittent fault. Return vehicle to customer and see if problem persists.

Fuel Pressure Drop

Step	Procedure	Action
1	Verify the following: <ol style="list-style-type: none"> Is there fuel in the tank of at least 1/8 tank? Is the tank supply manual shut-off valve fully open? Is battery voltage above 10 volts? 	Yes — Go to Step 2. No — Correct the fault condition and retry.
2	Determine fuel pressure. <ol style="list-style-type: none"> Measure and record fuel tank pressure. Measure and record fuel rail pressure with key on, engine running (KOER). Subtract the tank measurement from the KOER measurement. Is the resulting fuel pressure in the expected range? 	Yes — Go to Step 4. No — Go to Step 3.
3	Determine if the excess flow valve is tripped. <ol style="list-style-type: none"> Turn off the engine. Wait one minute and then restart the engine. Is the problem resolved? 	Yes — Go to the <i>Excess Flow Valve Check</i> procedure. No — Go to Step 4.
4	Determine fuel pressure at the time of the fault. <ol style="list-style-type: none"> While driving the vehicle, measure and record the fuel pressure during stumble. Does the pressure drop more than 10 psi during stumble? 	Yes — Go to Step 5. No — Go to Step 11.

737





ROUSH CleanTech Blue Bird Vision Liquid Propane Autogas (LPA) Service Manual

738

Step	Procedure	Action
5	<p>Check fuel pump operation.</p> <p>a. Turn the ignition switch to start and wait for the engine to crank.</p> <p>b. Check current draw to determine if fuel pumps run when engine cranks. When measuring fuel pump current a minimum of 2 amps should be recorded. Do both fuel pumps run?</p>	<p>Yes — Go to Step 7.</p> <p>No — Go to Step 6.</p>
6	<p>Check fuel pump fuse. Refer to the <i>Blue Bird Service Manual</i> for fuse box and circuit information.</p> <p>Is fuel pump fuse intact and OK?</p>	<p>Yes — Go to Step 9.</p> <p>No — Repair short and replace fuse.</p>
7	<p>Check tank solenoid (TS) and supply solenoid (SS) fuses. Refer to the <i>Blue Bird Service Manual</i> for fuse box and circuit information.</p> <p>a. Locate the TS and SS fuses.</p> <p>b. Are the fuses blown?</p>	<p>Yes — Find and repair the short; replace the fuse.</p> <p>No — Go to Step 8.</p>
8	<p>Verify that there is power and ground in the tank solenoid (TS) and supply solenoid (SS) wiring circuits.</p> <p>a. Check for +12 volts at the TS and SS connectors. See the <i>Tank Solenoid Electrical Check</i> procedure.</p> <p>b. Is +12 volts present at the TS connector?</p> <p>c. Is +12 volts present at the SS connector?</p>	<p>Yes — Voltage present at SS, replace FRPCM. Voltage present at TS, replace fuel supply valve assembly.</p> <p>No — Check for an open/short in the wiring circuit and repair.</p>
9	<p>Verify that there is power and ground in the wiring circuit to the tank.</p> <p>a. Check for +12 volts at the fuel pump 1 (FP1) and fuel pump 2 (FP2) connectors. See the <i>Fuel Rail Pressure Control Module (FRPCM) Electrical Check</i> procedure.</p> <p>b. Is +12 volts present at the FP1 connector?</p> <p>c. Is +12 volts present at the FP2 connector?</p>	<p>Yes — Refer to Engine Stumble, Stall, Rough Idle Step 13.</p> <p>No — Check for an open/short in the wiring circuit and repair.</p>
10	<p>Integrated Pressure Temperature Sensor (IPTS) Rationality</p> <p>Does temperature and pressure make sense to verification? See the <i>Integrated Pressure Temperature Sensor (IPTS) Electrical Check</i> procedure.</p>	<p>Yes — Go to Step 11.</p> <p>No — Verify that wiring in circuit is OK. If not, repair wiring. If OK, replace sensor.</p>
11	<p>Refer to the <i>Ford Powertrain Control/Emissions Diagnosis Service Manual</i> at www.motorcraft.com (2012 F-650 H561).</p>	—





BLUE BIRD

ROUSH
CLEANTECH

**ROUSH CleanTech Blue Bird Vision Liquid Propane Autogas (LPA)
Service Manual**

Fuel Level Indication Check

The ROUSH LPA fuel level indication system differs from the gasoline system because the fuel level sender is not wired directly to the instrument cluster. Instead, the fuel level sender is wired to the smart relay module (SRM), which reads the fuel level and transmits the signal to the instrument cluster via the controller area network (CAN) bus.

Symptom	Cause/Action to be taken
P-code?	There is a circuit fault that has been identified by the PCM. Initially follow the Ford service manual, whenever a circuit check is called for.
Doesn't read full after a fill?	This could be the result of either a fuel level indicator fault or an overflow protection device (OPD) valve triggering prematurely. See fill issues and the <i>Fuel Level Sender (FLS) Electrical Check</i> procedure for more information.

Tank Solenoid Electrical Check

CONNECTORS

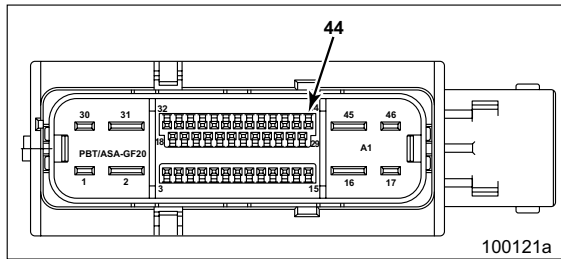

Figure 1

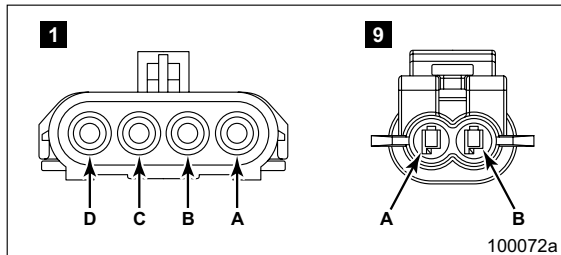

Figure 2 — Solenoid Harness Connectors



PROCEDURE

Step	Procedure	Action
1	Unplug the solenoid harness connector 9 from the tank solenoid.	Go to Step 2.
2	Use a multimeter to check the resistance of the tank solenoid. Is the resistance between 6–35 ohms?	Yes — Go to Step 3. No — Replace the tank solenoid.
3	Use a multimeter to check the voltage at the tank solenoid. a. With the ignition key on, check for voltage present at pin-A of the solenoid harness connector 9. Use the body as a reference ground. b. Is battery (B+) voltage present?	Yes — Supply circuit OK. No — Go to Step 4.
4	Check the fuse in the fuse box. Refer to the <i>Blue Bird Service Manual</i> for fuse box and circuit information. Is fuse blown?	Yes — Replace the fuse. No — Fuse OK. Go to Step 5.
5	Check supply circuit continuity from solenoid harness to fuse box. a. Check continuity between pin-A of the solenoid harness and the fuse box. Refer to the <i>Blue Bird Service Manual</i> for fuse box and circuit information. b. Is there good continuity in the circuit?	Yes — Go to Step 6. No — Repair circuit wiring.
6	Check ground circuit continuity from solenoid harness to smart relay module (SRM) connector. Refer to the <i>Blue Bird Service Manual</i> for SRM circuit information. a. Check continuity between pin-B connector 9 of solenoid harness to pin-44 at SRM connector. b. Is there good continuity in the circuit?	Yes — Go to <i>Smart Relay Module (SRM) Electrical Test</i> procedure. No — Repair circuit wiring.

740





**ROUSH CleanTech Blue Bird Vision Liquid Propane Autogas (LPA)
Service Manual**

**Fuel Rail Pressure Control Module
(FRPCM) Electrical Check**

CONNECTORS

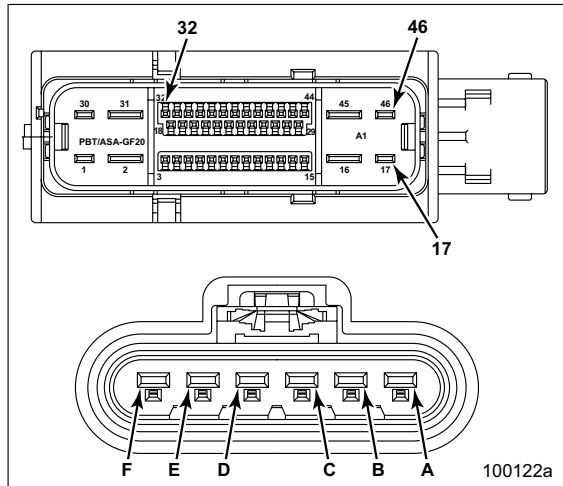

Figure 3

PROCEDURE

Step	Procedure	Action
1	Unplug the FRPCM connector.	Go to Step 2.
2	Using a multimeter, check the resistance of each solenoid. a. Check resistance across terminals at connector to FRPCM: • Supply Solenoid — Pin-A and pin-F • Flow Control Solenoid — Pin-B and pin-E • Bleed Solenoid — Pin-C and pin-D b. Is the resistance for each solenoid 6–35 ohms?	Yes — Go to Step 3. No — Replace the FRPCM if resistance for any one of the solenoids is not within the specified range.
3	Check supply voltage to FRPCM solenoids. Using a multimeter, measure voltage between the terminal of each solenoid and ground. Use the body as a reference ground.	Go to Step 4.
4	Supply Solenoid — Pin-A and body ground.	B+ Voltage? — Go to Step 5. No Voltage? — Go to Step 5.
5	Flow Control Solenoid — Pin-B and body ground.	B+ Voltage? — Go to Step 6. No Voltage? — Go to Step 8 if Step 4 has voltage; if Step 4 has no voltage, go to Step 6.



ROUSH CleanTech Blue Bird Vision Liquid Propane Autogas (LPA) Service Manual

742

Step	Procedure	Action
6	Bleed Solenoid — Pin-C and body ground.	B+ Voltage? — Continue with Step 9. No Voltage? — Go to Step 8 if Step 5 has voltage; if Step 5 has no voltage, go to Step 7.
7	Check the fuse in the fuse box. Refer to the <i>Blue Bird Service Manual</i> for fuse box and circuit information. Is the fuse blown?	Yes — Replace fuse. No — Go to Step 8.
8	Check continuity of the solenoid circuits. Refer to the <i>Blue Bird Service Manual</i> for fuse box and circuit information. a. Check continuity between: <ul style="list-style-type: none"> • Supply Solenoid — Pin-A, FRPCM harness connector and Blue Bird fuse box • Flow Control Solenoid — Pin-B, FRPCM harness connector and Blue Bird fuse box • Bleed Solenoid — Pin-C, FRPCM harness connector and Blue Bird fuse box b. Is there good continuity in all three circuits?	Yes — Go to Step 9. No — Repair circuit wiring.
9	Check continuity of the solenoid circuits. Refer to the <i>Blue Bird Service Manual</i> for fuse box and circuit information. a. Check continuity between: <ul style="list-style-type: none"> • Supply Solenoid — Pin-A, FRPCM harness connector and Blue Bird fuse box • Flow Control Solenoid — Pin-B, FRPCM harness connector and Blue Bird fuse box • Bleed Solenoid — Pin-C, FRPCM harness connector and Blue Bird fuse box b. Is there good continuity in all three circuits?	Yes — Go to <i>Smart Relay Module (SRM) Electrical Test</i> procedure. No — Repair circuit wiring.





**ROUSH CleanTech Blue Bird Vision Liquid Propane Autogas (LPA)
Service Manual**

**Integrated Pressure Temperature Sensor
(IPTS) Electrical Check**

IPTS Functional Test and DTC (diagnostic trouble codes). Refer to the *Ford Powertrain Control/Emissions Diagnosis Service Manual* at www.motorcraft.com (2012 F-650 H561).

CONNECTORS

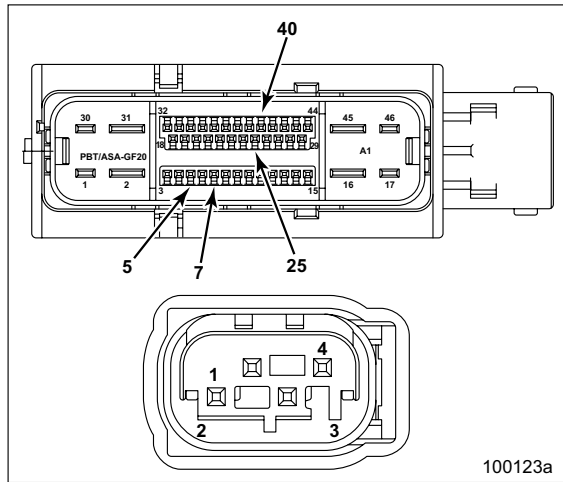

Figure 4

IPTS Temperature/Resistance Chart

Temp, °C	A R, Nom.	A R, Min.	A R, Max.
-40	316181	301183	331179
-30	169149	162304	175994
-20	94143	90938	97349
-10	54308	52781	55836
0	32014	31290	32738
10	19691	19346	20036
20	12474	12315	12633
25	10000	8900	10100
30	8080	7977	8182
40	5372	5282	5462
50	3661	3585	3737
60	2536	2474	2598
70	1794	1744	1844
80	1290	1250	1330
90	941.8	909.8	974.0
100	697.2	671.3	723.1
110	524.9	504.0	545.9
120	399.6	382.6	416.6
130	308.4	294.6	322.3
135	271.3	258.6	283.9



PROCEDURE

Step	Procedure	Action
1	Unplug the IPTS connector. Refer to the <i>Blue Bird Service Manual</i> for circuit information.	Go to Step 2.
2	Check resistance of the IPTS. a. With vehicle at ambient room temperature (20– 30°C, 68–86°F) use a multimeter to measure resistance between pin-1 and pin-3 of the IPTS connector. b. Is the resistance between 8K–12K ohms?	Yes — Go to Step 3. No — Replace the IPTS.
3	Check reference voltage (+5V) at pin-4 of the IPTS connector. a. Using a multimeter, measure the reference voltage (+5V) at pin-4 of the IPTS connector. Use the body as a reference ground. b. Is the voltage +5V?	Yes — Go to <i>Smart Relay Module (SRM) Electrical Test</i> procedure. No — Go to Step 4.
4	Check circuit continuity between the IPTS and the smart relay module (SRM). Refer to the <i>Blue Bird Service Manual</i> for circuit information. a. Check continuity between: <ul style="list-style-type: none"> • Pin-1 of IPTS connector and pin-40 of SRM connector • Pin-2 of IPTS connector and pin-7 of SRM connector • Pin-3 of IPTS connector and pin-5 of SRM connector • Pin-4 of IPTS connector and pin-25 of SRM connector b. Is there good continuity in the circuits?	Yes — Go to <i>Smart Relay Module (SRM) Electrical Test</i> procedure. No — Repair circuit wiring.

744





**ROUSH CleanTech Blue Bird Vision Liquid Propane Autogas (LPA)
Service Manual**

Fuel Pump Electrical Test

CONNECTORS

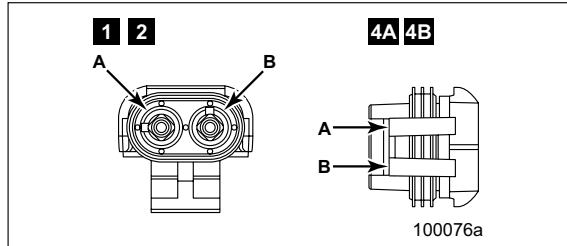

Figure 5 — In-Tank Harness Connectors

Step	Procedure	Action
1	<p>Check fuel pump circuit continuity.</p> <p>a. Unplug the fuel pump connectors 1 and 2 of ROUSH CleanTech in-tank harness from the Blue Bird harness. Refer to the <i>Blue Bird Service Manual</i> for circuit information.</p> <p>b. Using a multimeter, measure resistance of each fuel pump.</p>	Go to Step 2 to check fuel pump 1. Go to Step 3 to check fuel pump 2.
2	<p>Check fuel pump 1.</p> <p>a. Using a multimeter, measure resistance of fuel pump 1 across the terminals of fuel pump 1 connector.</p> <p>b. Is resistance between 0.4–1.0 ohm?</p>	<p>Yes — Go to Step 3</p> <p>No — If resistance is higher or open circuit, Go to Step 4.</p>
3	<p>Check fuel pump 2.</p> <p>a. Using a multimeter, measure resistance of fuel pump 2 across the terminals of fuel pump 2 connector.</p> <p>b. Is resistance between 0.4–1.0 ohm?</p>	<p>Yes — Go to Step 7</p> <p>No — If resistance is higher or open circuit, Go to Step 4.</p>
4	<p>Unplug in-tank harness connectors from each fuel pump.</p> <p>Unplug the fuel pump connectors of in-tank harness from the fuel pump assembly.</p>	Go to Step 5 to check fuel pump 1. Go to Step 6 to check fuel pump 2.
5	<p>Check resistance of fuel pump 1.</p> <p>a. Using a multimeter, measure resistance for fuel pump 1 across the terminals of fuel pump 1 connector.</p> <p>b. Is resistance between 0.4–1.0 ohm?</p>	<p>Yes — Go to Step 6.</p> <p>No — If resistance is higher or open circuit, replace the fuel pump assembly.</p>
6	<p>Check resistance of fuel pump 2.</p> <p>a. Using a multimeter, measure resistance for fuel pump 2 across the terminals of fuel pump 2 connector.</p> <p>b. Is resistance between 0.4–1.0 ohm?</p>	<p>Yes — Go to Step 7.</p> <p>No — If resistance is higher or open circuit, replace the fuel pump assembly.</p>



ROUSH CleanTech Blue Bird Vision Liquid Propane Autogas (LPA) Service Manual

Step	Procedure	Action
7	<p>Check harness circuit continuity of the fuel pumps with fuel pump control module (FPCM).</p> <p>a. Refer to the <i>Blue Bird Service Manual</i> for circuit information.</p> <p>b. Is there good continuity in the circuits?</p>	<p>Yes — Go to 8.</p> <p>No — Repair circuit wiring.</p>
8	<p>Refer to Fuel Pump Control Module (FPCM) Electrical Continuity Test procedure.</p>	—

Fuel Pump Control Module (FPCM) Electrical Continuity Test

Step	Procedure	Action
	<p>For FPCM functional testing and diagnostic trouble codes, refer to the <i>Ford Powertrain Control/Emissions Diagnosis Service Manual</i> at www.motorcraft.com.</p> <p>Verify the following:</p>	
1	<p>Check FPCM circuit continuity to Blue Bird fuse box. Refer to the <i>Blue Bird Service Manual</i> for circuit information.</p> <p>a. Using a multimeter, check VPWR (V+) circuit to fuse box.</p> <p>b. Is there good continuity in the circuit?</p>	<p>Yes — Go to Step 2.</p> <p>No — Repair circuit wiring.</p>
2	<p>Check fuse for FPCM at Blue Bird fuse box. Refer to the <i>Blue Bird Service Manual</i> for fuse box and circuit information.</p> <p>a. Check the fuse at the fuse box.</p> <p>b. Is the fuse blown?</p>	<p>Yes — Replace fuse with the correct value fuse.</p> <p>No — Go to Step 4.</p>
3	<p>Check for continuity in the circuits.</p> <p>a. Check for continuity in the circuits.</p> <p>b. Is there good continuity in the circuits?</p>	<p>Yes — Refer to <i>Ford Powertrain Control/Emissions Diagnosis Service Manual</i> for functional testing of the FPCM.</p> <p>No — Repair circuit wiring.</p>

746





**ROUSH CleanTech Blue Bird Vision Liquid Propane Autogas (LPA)
Service Manual**

Smart Relay Module (SRM) Electrical Test

CONNECTORS

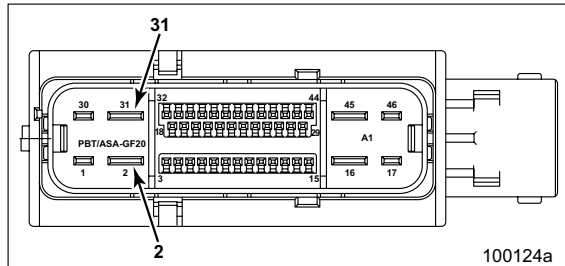

Figure 6 — SRM Connector

PROCEDURE

Step	Procedure	Action
1	Disconnect the SRM connector. Refer to the <i>Blue Bird Service Manual</i> for circuit information.	Go to Step 2.
2	Check for battery voltage (B+) to the SRM. a. Using a multimeter, check for B+ voltage at cavity 2 of the SRM connector. Use the body as a reference ground. b. Is there voltage (B+)?	Yes — Go to Step 5. No — Go to Step 3.
3	Check for continuity in the circuits. a. Check circuit continuity between cavity 2 of the SRM connector and the Blue Bird fuse box. Refer to the <i>Blue Bird Service Manual</i> for fuse box and circuit information. b. Is there good continuity in the circuit?	Yes — Go to Step 4. No — Repair circuit wiring.
4	Check SRM fuse at fuse box. a. Check condition of SRM power fuse in the Blue Bird fuse box. Refer to the <i>Blue Bird Service Manual</i> for fuse box and circuit information. b. Is fuse blown?	Yes — Replace fuse. No — Go to Step 5.
5	Check the SRM ground circuit for continuity. a. Using a multimeter, check ground at cavity 31 of the SRM connector. Use the body as a reference ground. b. Is there good continuity?	Yes — Go to Step 6. No — Repair circuit wiring.



6	<p>Check for Activation signal to SRM.</p> <p>a. Using a multimeter, check for continuity between pin-26 of the SRM connector and the Blue Bird fuse box. Refer to the <i>Blue Bird Service Manual</i> for fuse box and circuit information.</p> <p>b. Is there good continuity in the circuit?</p>	<p>Yes — Go to Step 8.</p> <p>No — Go to Step 7.</p>
7	<p>Check condition of fuse in fuse box.</p> <p>a. Check condition of fuse in Blue Bird fuse box. Refer to the <i>Blue Bird Service Manual</i> for fuse box and circuit information.</p> <p>b. Is fuse blown?</p>	<p>Yes — Replace fuse.</p> <p>No — Repair circuit wiring.</p>
8	<p>Check CAN wiring for SRM circuit continuity. Refer to the <i>Blue Bird Service Manual</i> for circuit information.</p> <p>a. Check SRM circuits for continuity.</p> <p>b. Is there good continuity in the circuits?</p>	<p>Yes — Go to SRM, Can Bus Circuit Wiring under <i>Diagnostic Trouble Codes (DTC)</i> — <i>LPA-Fueled Vehicles</i>.</p> <p>No — Repair circuit wiring.</p>

Fuel Level Sender (FLS) Electrical Check

748

CONNECTORS

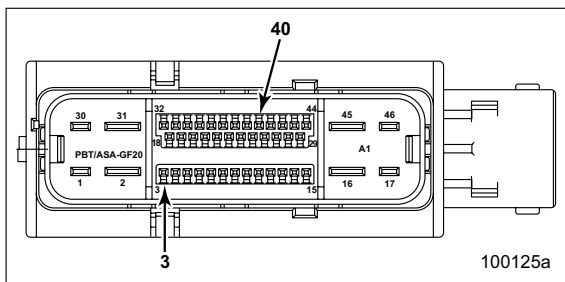

Figure 7 — SRM Connector

Step	Procedure	Action
	For FLS functional testing and diagnostic trouble codes, refer to <i>Diagnostic Trouble Codes (DTC)</i> — <i>LPA-Fueled Vehicles</i> . Refer to the <i>Ford Powertrain Control/Emissions Diagnosis Service Manual</i> for more information.	
1	<p>Unplug connector and check resistance in FLS circuit wiring.</p> <p>a. Disconnect the SRM harness connector.</p> <p>b. Using a multimeter, measure the resistance between pin-3 and pin-40 of the SRM harness connector.</p> <p>c. Is resistance between 24–260 ohms?</p>	<p>Yes — Go to Step 6.</p> <p>No — Go to Step 2.</p>



BLUE BIRD

ROUSH
 CLEANTECH

**ROUSH CleanTech Blue Bird Vision Liquid Propane Autogas (LPA)
 Service Manual**

Step	Procedure	Action
2	Unplug connector and check resistance of the FLS. <ol style="list-style-type: none"> Disconnect the 4-pin connector 1 (ROUSH harness 9S377) from Blue Bird harness connector. Refer to the <i>Blue Bird Service Manual</i> for circuit information. Using a multimeter, measure the resistance between pin-C and pin-D of connector 1. Is resistance between 24–260 ohms? 	Yes — Go to Step 6. No — Go to Step 3.
3	Unplug connector and check resistance of the FLS. <ol style="list-style-type: none"> Disconnect the FLS connector 6. Using a multimeter, measure the resistance across the FLS pins. Is resistance between 24–260 ohms? 	Yes — Go to Step 4. No — Replace FLS.
4	Check circuit wiring continuity between FLS connector and SRM connector. <ol style="list-style-type: none"> Disconnect connector from SRM and connector 6 of FLS. Check continuity between pin-B, connector 6 of solenoid harness and pin-3 in connector of SRM. Refer to the <i>Blue Bird Service Manual</i> for circuit information. Is there good continuity in the circuit? 	Yes — Go to Step 5. No — Repair circuit wiring.
5	Check circuit continuity. <ol style="list-style-type: none"> Check continuity between pin-A, connector 6 of solenoid harness and pin-40 in connector of SRM. Refer to the <i>Blue Bird Service Manual</i> for circuit information. Is there good continuity in the circuit? 	Yes — Go to Step 6. No — Repair circuit wiring.
6	Perform the SRM tests.	Go to <i>Smart Relay Module (SRM) Electrical Test</i> procedure.

749



Copyright © 2012 ROUSH CleanTech, LLC. All Rights Reserved.

