



**2009 - 2010**

**Ford F-250 / F-350**

**LIQUID PROPANE INJECTION**

Rev. 2/11/2011

**SERVICE MANUAL SUPPLEMENT**

## **FOREWORD**

This manual is a supplement to the Ford F-250/F-350 Workshop Manuals (referenced as the "Ford WSM" where applicable in this manual). It is intended to provide technicians with the procedures required to maintain and service the unique components of the ROUSH CleanTech F-250/F-350 Liquid Propane Injection vehicles. Service procedures for vehicle components shared in common with Ford F-250/F-350 vehicles will be referenced to and covered in the Ford Workshop Manual.

This manual supplement includes a Table of Contents to direct you to the information contained within.

## **LIMITED LIABILITY DISCLAIMER**

The information in this publication was accurate and effective at the time the publication was approved for printing and is subject to change without notice or liability. ROUSH CleanTech reserves the right to revise the information herein and to make changes and discontinue production of described parts at any time.

## TABLE OF CONTENTS

<b>FOREWORD</b> .....	<b>i</b>
<b>LIMITED LIABILITY DISCLAIMER</b> .....	<b>i</b>
<b>INTRODUCTION</b> .....	<b>1</b>
<b>General Information</b> .....	<b>1</b>
ROUSH CleanTech Technical Assistance.....	1
Start Sequence.....	1
Fill Stations.....	1
Range and Fuel Economy.....	2
<b>Safety Information</b> .....	<b>2</b>
Alert Messages.....	2
<b>Installation, Garaging and Training</b> .....	<b>3</b>
<b>Purging and Venting (Tanks and Lines)</b> .....	<b>3</b>
<b>VEHICLE INFORMATION</b> .....	<b>4</b>
<b>Build Data</b> .....	<b>4</b>
Vehicle Emissions Control Information (VECI) Labels.....	4
VECI Label Location.....	5
<b>DESCRIPTION AND OPERATION</b> .....	<b>6</b>
<b>System Overview</b> .....	<b>6</b>
Vehicle Starting.....	8
<b>System Components and Function</b> .....	<b>8</b>
Fuel Rails and Injectors.....	8
Flow Control Solenoid (FCS).....	9
Injection Pressure and Temperature Sensor (IPTS).....	9
Fuel Supply and Return Lines.....	10
Fuel Tanks.....	10
Multivalve.....	11
FUEL LEVEL SENDING UNIT.....	12
Fuel Filler Valve and Fill Line.....	13
FILL VALVE.....	13
IN-LINE FILTER.....	13
<b>Glossary</b> .....	<b>14</b>

<b>COMPONENT LOCATOR</b> .....	<b>16</b>
<b>Engine Components</b> .....	<b>16</b>
Fuel Rails and Injectors.....	16
<b>Chassis</b> .....	<b>17</b>
Fuel Lines and Tanks.....	17
<b>TROUBLESHOOTING</b> .....	<b>18</b>
<b>Symptom Tables</b> .....	<b>18</b>
Fuel Odor.....	18
<b>Diagnostic Flow Charts</b> .....	<b>19</b>
No Fill Condition .....	19
Slow Fill Condition.....	25
No Start Condition .....	27
Fuel Pump Diagnostics .....	28
Fuel Sending Unit Diagnostics .....	34
Fuel Fill Table.....	37
<b>MAINTENANCE REQUIREMENTS</b> .....	<b>38</b>
<b>Schedule</b> .....	<b>38</b>
<b>MAINTENANCE PROCEDURES</b> .....	<b>38</b>
<b>Intake Air Filter Inspection</b> .....	<b>38</b>
<b>In-Line Fuel Filter Replacement</b> .....	<b>39</b>
<b>REPAIR PROCEDURES</b> .....	<b>40</b>
<b>Preparing Vehicle for Service</b> .....	<b>40</b>
Alert Messages.....	40
Changing Fuses .....	41
Pressure Relief.....	42
Purging .....	42
Purging the Fuel Tank .....	42
Purging System Fuel Lines .....	42
Manual Fuel Shutoff.....	43
Opening Manual Shutoff Valve .....	44
Removing Intake Airbox Cover .....	45
Installing Intake Airbox Cover .....	46

<b>Fuel System Component Removal Procedures</b> .....	<b>47</b>
Removing Pressure Relief Hose.....	47
Removing Flow Control Solenoid.....	48
Removing Fuel Lines (In-Bed Tank to Solenoid).....	48
Removing Fuel Lines (Under-Vehicle Tank to Solenoid).....	49
Removing Fuel Lines (Solenoid to Engine) .....	49
Removing Fuel Fill Line (Filter to Tank).....	51
Removing Fuel Filler Neck .....	52
Removing Fuel Filter Assembly.....	52
Removing Fuel Fill Line (Neck to Filter).....	53
Removing Left (Driver’s Side) Fuel Rail .....	53
Removing Right (Passenger’s Side) Fuel Rail.....	54
Removing Fuel Injector .....	55
Removing Injection Pressure and Temperature Sensor.....	56
<b>Fuel Tank Removal Procedures</b> .....	<b>56</b>
Purging Fuel Tank.....	56
Removing In-Bed Tank.....	56
Removing Under-Vehicle Tank .....	59
<b>Fuel Tank Installation Procedures</b> .....	<b>67</b>
LPG System Bleed and Fill Procedure .....	67
Installing Under-Vehicle Tank.....	68
Installing In-Bed Tank.....	77
<b>Fuel System Component Installation Procedures</b> .....	<b>81</b>
Before Installing Components .....	81
Installing Injection Pressure and Temperature Sensor .....	82
Installing Fuel Injector .....	82
Installing Right (Passenger’s Side) Fuel Rail .....	82
Installing Left (Driver’s Side) Fuel Rail.....	83
Installing Fuel Filter Assembly .....	85
Installing Fuel Filler Neck.....	85
Installing Fuel Fill Line (Filler Neck to Filter).....	87
Installing Fuel Fill Line (Fuel Filter to Tank) .....	87
Installing Fuel Lines (Solenoid to Engine).....	88
Installing Fuel Lines (Under-Vehicle Tank to Solenoid) .....	88

**ROUSH® CleanTech F-250/F-350 Liquid Propane Injection  
Service Manual Supplement**

---

Installing Fuel Lines (In-Bed Tank to Solenoid) .....	89
Installing Flow Control Solenoid .....	89
Installing Pressure Relief Hose .....	90
<b>SPECIFICATIONS .....</b>	<b>91</b>
<b>Engine Specifications.....</b>	<b>91</b>
Roush CleanTech Conversion Ford 5.4L LPI Engine.....	91
<b>Chassis Specifications .....</b>	<b>92</b>
Vehicles with In-Bed Tank.....	92
Vehicles with Under-Vehicle Tank.....	92
<b>Fastener Torque Values .....</b>	<b>93</b>
<b>SCHEMATICS .....</b>	<b>94</b>
<b>Fuel System Flow Diagrams .....</b>	<b>94</b>
Fuel Flow .....	94
<b>Electrical Wiring Diagrams .....</b>	<b>95</b>
Wiring Schematic.....	95
Vehicle Harness .....	96
In-Tank Wire Harness .....	97
<b>TOOLS AND EQUIPMENT .....</b>	<b>98</b>
<b>Special Tools .....</b>	<b>98</b>

## **INTRODUCTION**

### **General Information**

This manual applies to the following ROUSH CleanTech Liquid Propane Injection applications:

- 2009–2010 F-250/F-350 5.4L-3V

This manual is a supplement to the regular Ford Workshop Manual, covering the unique components of the ROUSH CleanTech Liquid Propane Injection system:

- Fuel supply line
- Fuel return line
- Flow Control Solenoid (FCS)
- Fuel rails
- Fuel filler lines, valve and filter
- Fuel tank

The ROUSH CleanTech parts generally serve the same functions as the Ford parts they replace.

The online Ford Workshop Manual, if available, continues to apply to all other details. The diagnostic chart in this manual directs the technician to appropriate sections of the Ford manual for applicable remedies in some situations.

Propane, like other fuels, must be handled safely with knowledge of its characteristics. Training in propane characteristics and handling is available through the Propane Education and Research Council (PERC), 1140 Connecticut Avenue, Washington, DC 20036. Their web address is [www.propanecouncil.org](http://www.propanecouncil.org).

### **ROUSH CleanTech Technical Assistance**

Call ROUSH CleanTech customer service at **800.59.ROUSH** with any questions regarding ROUSH CleanTech Liquid Propane Injection systems.

### **Start Sequence**

The Roush CleanTech Liquid Propane Injection system is fully integrated with Ford's One Touch Starting system. The vehicle operator turns the key to the **Start** position and releases it. The computer senses the pressure/temperature in the fuel lines and starts the fuel pump. The pump sends liquid propane through the lines driving the vapor back to the tank to become liquid again. When the pressure/temperature sensor reports that the lines are full of liquid, the computer energizes the starter and the ignition system. The entire sequence generally takes from 1.5 to 10 seconds (may extend to 20 seconds under extreme ambient conditions).

### **Fill Stations**

Propane is readily available anywhere in the United States. To locate the nearest station, check with <http://www.afdc.energy.gov/afdc/locator/stations/>.

## ROUSH® CleanTech F-250/F-350 Liquid Propane Injection Service Manual Supplement

---

ROUSH CleanTech recommends facilities designed for automotive refueling. Other locations may have low output pumps, resulting in slow or no fill, or low quality fuel which can result in premature component failure.

### Range and Fuel Economy

Propane contains less energy per unit volume than gasoline. Therefore, customers will generally experience fuel economy (mile per gallon) 15–30% lower than gasoline.

Vehicle range will vary based on driving conditions and loading.

### Safety Information

The National Fire Protection Association (NFPA) publishes a code book of rules that apply to the storage, handling, transportation, and use of liquefied petroleum gas (LP-Gas or LPG). The book is known as **NFPA 58**. It is revised as necessary and published every other year. This code is adopted as law in virtually every political subdivision in the United States. Check with your local authorities for regulations applicable to liquid propane.

### Alert Messages

The following alert messages appear from time to time in inappropriate places in this manual. Ensure that all personnel in the immediate area are aware of these reminders.

**▲ Danger:** Although propane is nontoxic, nonpoisonous, has the lowest flammability range of any alternative fuel and dissipates quickly when released into the atmosphere, propane vapor is heavier than air and seeks the lowest point. When the ratio of propane to air is between 2.2% and 9.6%, propane will burn in the presence of an ignition source at 940°F (504°C) or hotter. Keep away from heat, sparks, flames, static electricity or other sources of ignition. Failure to heed this danger may result in severe personal injury or death.

**▲ Danger:** The fuel supply lines remain pressurized after engine shutdown. Keep away from heat, sparks, flames, static electricity or other sources of ignition. Do NOT enter storage areas or confined space unless they are adequately ventilated. Failure to heed this danger may result in severe personal injury or death.

**▲ Danger:** Do NOT carry lighted smoking materials or smoke while working on fuel system components. Failure to heed this danger could result in severe personal injury or death.

**▲ Danger:** Disconnect the battery ground at the battery to ensure that the vehicle electrical system has no current. Failure to heed this danger could result in severe personal injury or death.



## **Installation, Garaging and Training**

Chapter 11 of **NFPA 58** applies to engine fuel systems using LP-Gas in internal combustion engines, including containers, container appurtenances, carburetion equipment, piping, hose and fittings and their installation. Additionally, this chapter applies to garaging of vehicles and to the training of personnel.

Paragraph 11.2 specifies that each person engaged in installing, repairing, filling or otherwise servicing an LP-Gas engine fuel system shall be trained. Contact the Propane Education and Research Council to learn more about their CETP E-Learning computer-based training program: [stuart.flatow@propanecouncil.org](mailto:stuart.flatow@propanecouncil.org), or [vincent.sibilia@propanecouncil.org](mailto:vincent.sibilia@propanecouncil.org).

## **Purging and Venting (Tanks and Lines)**

Venting of LP-Gas to the atmosphere is covered by paragraphs 7.3.1, General, and 7.3.2, Purging of **NFPA 58, 2008 edition**. Refer to **NFPA 58, Local Codes and Proper Training** for specific information relating to safe venting of LPG.

## VEHICLE INFORMATION

### Build Data

ROUSH CleanTech emissions certification information is recorded on the ROUSH CleanTech Vehicle Emissions Control Information (VECI) label. The label is vehicle-specific and is required by law to be on the vehicle to which it is assigned along with the Ford VECI label.

### Vehicle Emissions Control Information (VECI) Labels

<b>ROUSH.</b>	ROUSH INDUSTRIES VEHICLE EMISSIONS CONTROL INFORMATION
Conforms to regulations: 2011 MY INCOMPLETE LPG Weight limits refer to Emission Certification only DO NOT EXCEED VEHICLE GVWR (See Incomplete Vehicle Manual)	
U.S. EPA: T2B5 LDT4 OBD: CA II	
California: SULEV OBD: CA II Fuel: LPG	
Completed Vehicle Maximums: GVWR: 9600# max CurbW: 6949# max. Frontal Area: 60.0 ft2 max.	
No adjustments needed	TWC/HO2S/SFI/HAFS
5.4L-Group: BRIT05.45HK Evap: BRIIF0265LPG	▽ P11C2-9C485-DA

Figure 1 — ROUSH CleanTech VECI Label (Typical)

	<b>Ford Motor Company</b> VEHICLE EMISSION CONTROL INFORMATION
Conforms to regulations: 2008 MY FFV	
U.S. EPA: IT2B8 LDT4 OBD: F II	
California: SULEV Conforms to emissions standards.	
TWC/HO2S/SFI	No adjustments needed.
5.4L-Group: 8FMXT05.44HF Evap: 8FMXR0250NBR	
▽8W7E-9C485-R R L	<b>SAMPLE</b>

Figure 2 — Ford VECI Label (Typical)

# ROUSH® CleanTech F-250/F-350 Liquid Propane Injection Service Manual Supplement

---

## VECI Label Location

The ROUSH CleanTech VECI label appears along with the original Ford VECI label in the following location:

- **F-250/F-350** — under hood at side near hood prop, passenger side

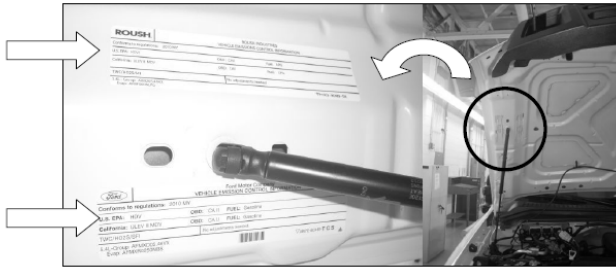

Figure 3 — VECI Label Location

## DESCRIPTION AND OPERATION

### System Overview

The ROUSH CleanTech Liquid Propane Injection (LPI) system consists of a propane fuel tank, fuel pump, fuel rails and lines, injectors and electronic controls. The system is simple and easily serviced with no user adjustment required.

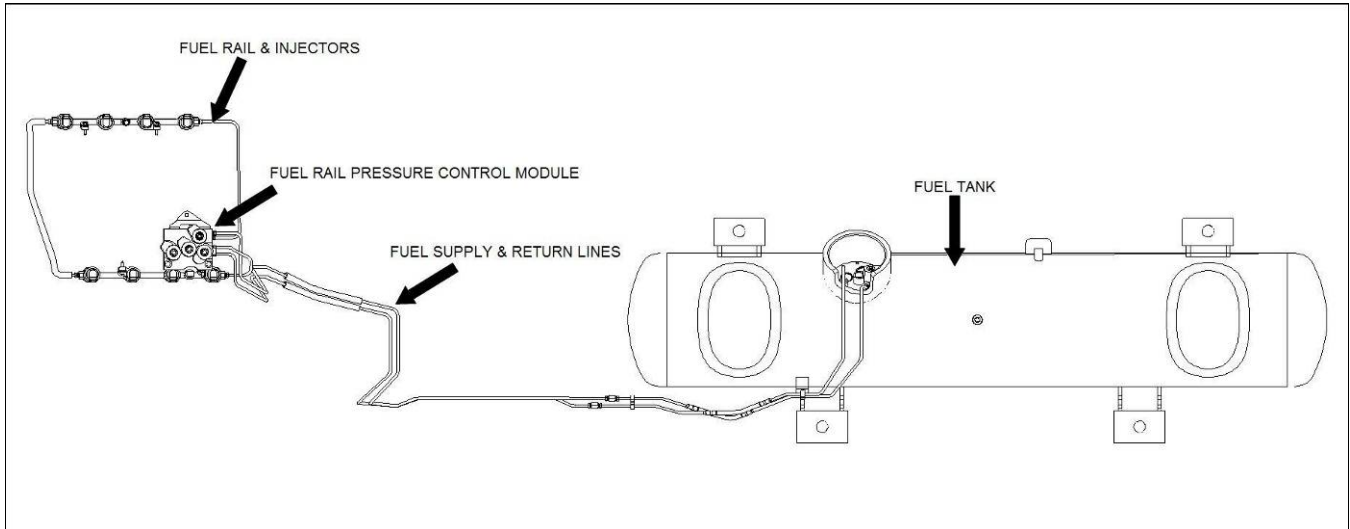

Figure 4 — ROUSH CleanTech LPI Fuel System — Under Vehicle Tank (Typical)

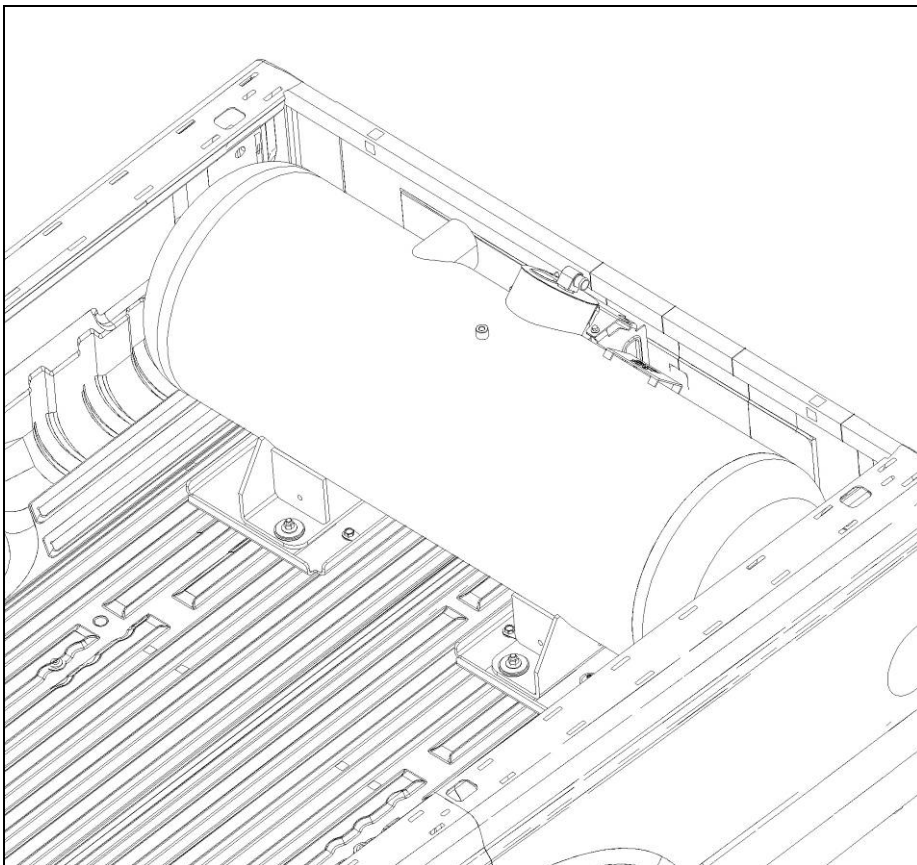

Figure 5 — ROUSH CleanTech LPI Fuel System — In Bed Tank (Typical)

## ROUSH® CleanTech F-250/F-350 Liquid Propane Injection Service Manual Supplement

---

Propane is stored in the vehicle fuel tank under pressure as a liquid. The pressure in the tank is determined by the temperature of the fuel, ranging from 0 psi at minus 44°F, to 312 psi at 145°F. The tank has an overpressure safety device which vents the tank at pressures over 312 psi.

There are two propane filters in the system. The primary filter is located in the fuel fill line which is intended to filter out the majority of contaminants that may be present in the fuel. The primary filter must be replaced every 50,000 miles. A secondary fuel filter is located after the fuel pump inside the tank which is intended to ensure that no contaminants reach the fuel injectors.

ROUSH CleanTech LPI vehicles require HD-5 propane, rated for automotive use. Use of HD-10 or other substandard propane may result in excess contamination of the system and failure of the fuel pump, injectors and in-tank filter.

A pump inside the tank delivers liquid propane to the injectors through the fuel supply line and the fuel rails. Excess fuel flows back to the tank through the fuel return line. Fuel pressure is regulated by the Flow Control Solenoid (FCS) which includes a small orifice to restrict return flow in normal conditions; and a bypass circuit to allow maximum fuel flow prior to engine starting or during extremely hot conditions. The FCS is a separate component in F-250/F-350 applications and is mounted on the left frame side rail.

In order to safely store pressurized liquid propane in the vehicle, the fill system must ensure that the tank is not filled beyond 80% of its total volume. This ensures that sufficient expansion volume is present in case of significant tank temperature changes.

The fuel fill system includes the following components:

1. Fuel fill valve, cap and mounting bracket
2. Fuel fill hoses
3. Fuel fill filter
4. Fuel tank internal components
  - a. Fuel fill solenoid
  - b. Fill pressure switch
  - c. 80% level sensor

During a fill event, the system functions as follows:

1. Customer connects fuel filler nozzle to fill valve and activates the fuel pump.
2. Fuel pressure in the fill line causes the pressure switch to close. In order for the switch to close, pressure in the fill line must be at least 10 psi higher than tank pressure, otherwise no fill is possible.
3. The fill pressure switch provides a ground to the 80% level sensor to activate the circuit. If the fuel level is below the 80% level, the sensor provides ground to the fuel fill solenoid, allowing fuel to enter the tank.
4. Once the fuel reaches the 80% fill level, the 80% level sensor de-activates, causing the fill solenoid to close.

**Note** — Some fuel pumps may have sufficient pressure to allow a small fuel flow into the tank even with the fill solenoid closed. The operator should stop the fill as soon the fuel flow drops noticeably.

## **Vehicle Starting**

The ROUSH CleanTech LPI system is fully integrated using Ford's One Touch Integrated Start (OTIS) system. When the ignition key is turned to crank and released to the On position, the PCM opens the Flow Control Solenoid (FCS) and engages the fuel pump. As soon as the fuel rail temperature and pressure are acceptable to ensure liquid fuel at the injectors, the starter engages and the vehicle starts with no further action required from the operator. This delay period is usually less than 5 seconds, but may be up to 30 seconds in extremely hot conditions. During the delay period, the wrench light on the dash blinks to signal that the system is active.

## **System Components and Function**

### **Fuel Rails and Injectors**

The Ford OEM fuel rails and injectors are replaced with ROUSH CleanTech LPI fuel rail and injector assemblies, including injection pressure and temperature sensor (IPTS), Schrader port for service and crossover fuel line.

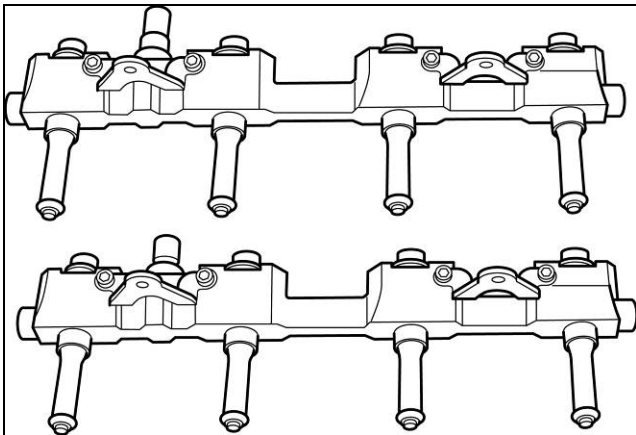

**Figure 6 — Fuel Rails and Injectors**

### Flow Control Solenoid (FCS)

On F-Series vehicles a Flow Control Solenoid (FCS) is used to control fuel flow through the fuel rails. The FCS is installed in the fuel return line and mounted on the left frame side rail in the under-cab area.

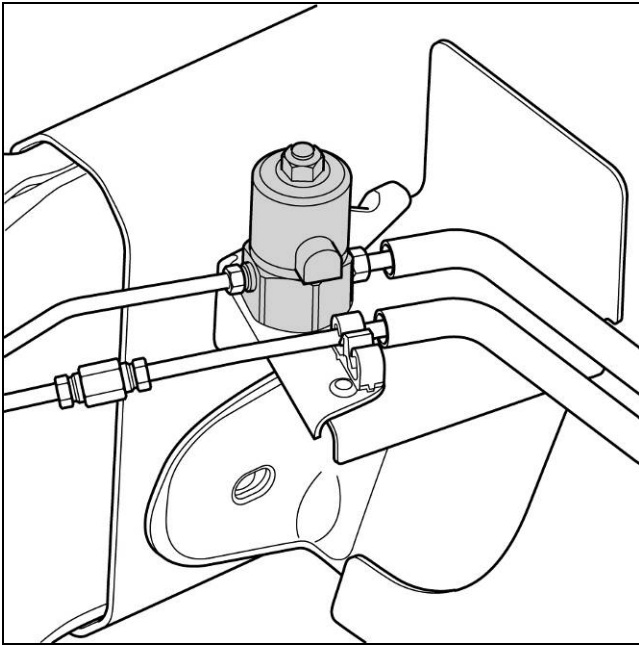

Figure 7 — Flow Control Solenoid

### Injection Pressure and Temperature Sensor (IPTS)

The IPTS is used to monitor fuel pressure and temperature. On F-250/F-350 applications the IPTS is read directly by the PCM.

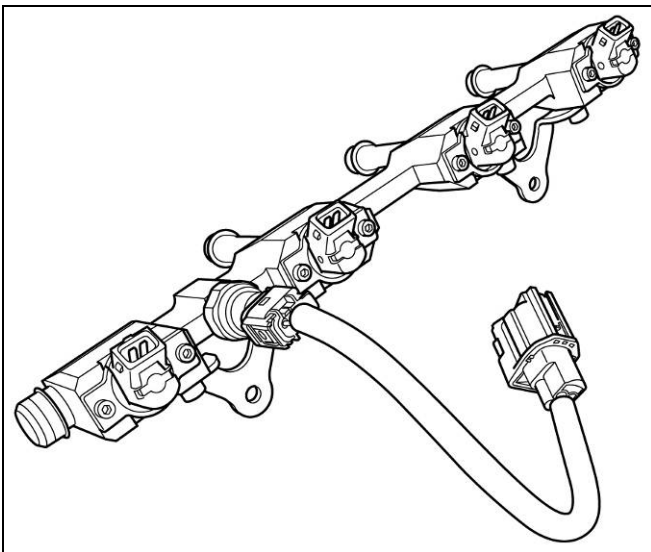

Figure 8 — Injection Pressure and Temperature Sensor

## Fuel Supply and Return Lines

The Ford OEM fuel lines are replaced with formed stainless steel lines following the original production line routings. The formed lines are produced in many lengths and configurations to accommodate the various vehicle models. The lines may be installed with two or three sectioned assemblies depending on the specific vehicle model. All sections, supply and return, include unions as part of the assembly.

The stainless steel fuel lines are retained in the chassis using the Ford OEM retention clips.

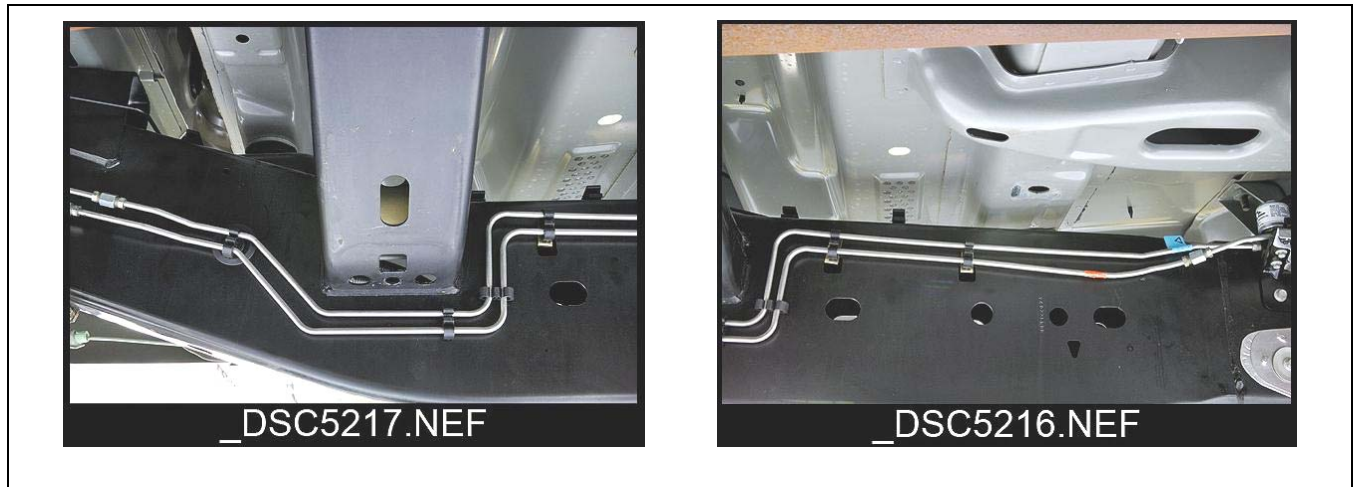

Figure 9 — Stainless Fuel Supply and Return Lines (Typical)

## Fuel Tanks

Different tank configurations are used based on the vehicle model. A long cylindrical tank mounted under vehicle is used for F-250/F-350 LPI vehicles. Optional on F-250/F-350 models is a large-diameter cylindrical tank mounted in the pickup bed. The in-bed tank with its greater fuel capacity provides extended range.

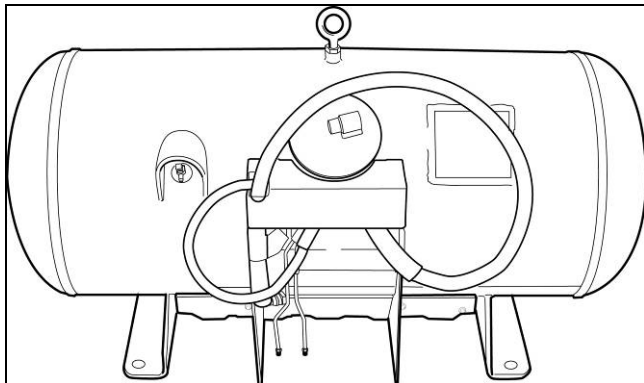
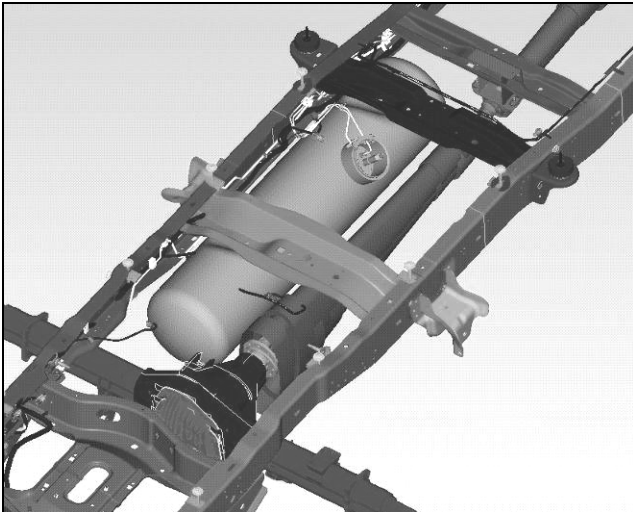

Figure 10 — In Bed Fuel Tank

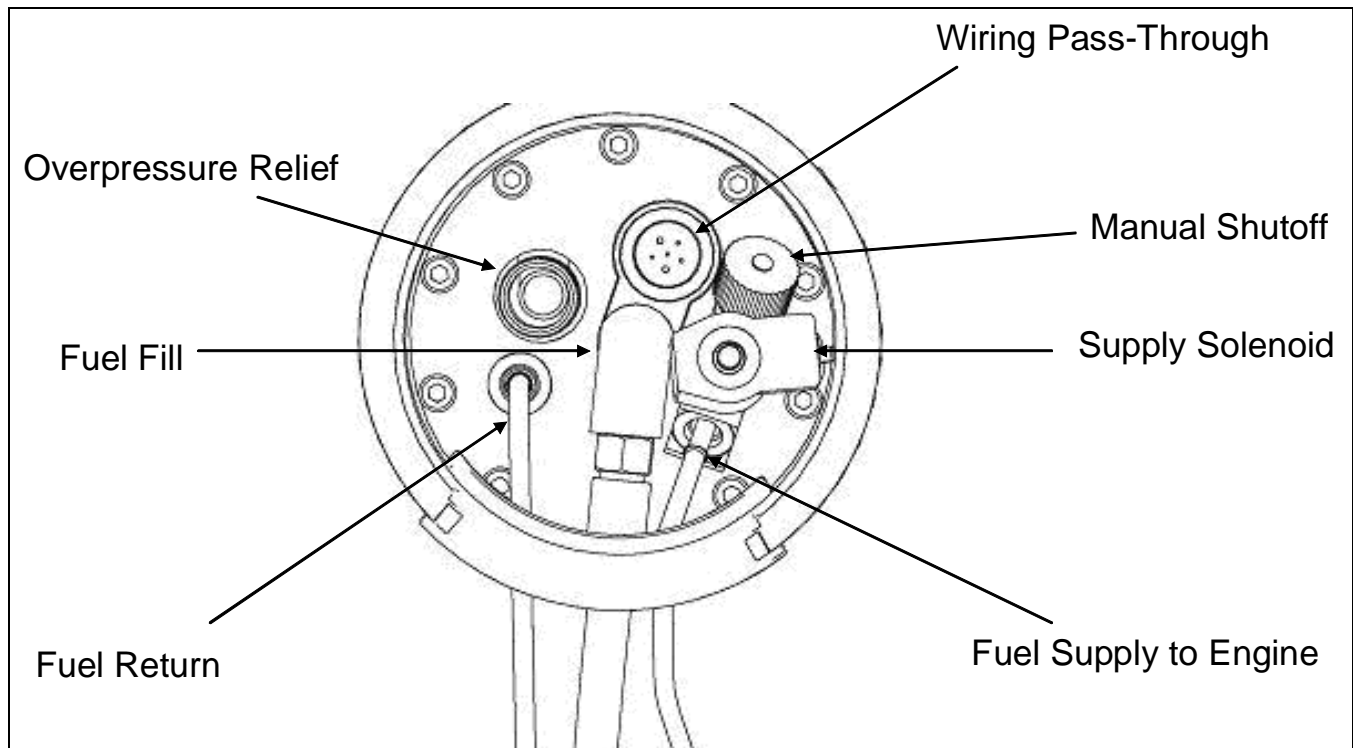



**Figure 11 — Under Vehicle Fuel Tank**

All ROUSH CleanTech LPI vehicle fuel tanks regardless of configuration are fitted with the same valve assemblies and control units. These include the Multivalve assembly, Fuel Control Solenoid, Fuel Fill Solenoid, 80% Level Sensor, Fill Pressure Switch and the Fuel Level Sending Unit.

### Multivalve



**Figure 12 — Multivalve Assembly**

The Multivalve attaches directly to the fuel tank and serves as the main interface between fuel tank and vehicle. As the name implies, the Multivalve consists of a number of valves incorporated into one unit. The included valves are:

## ROUSH® CleanTech F-250/F-350 Liquid Propane Injection Service Manual Supplement

---

**Fill Valve** — Located where fuel enters into the fuel tank, the fill valve is opened electrically by the Fuel Fill Solenoid during the fill process. It also incorporates double back redundant check valves which close when vehicle tank pressure is greater than pressure outside of tank to prevent fuel from escaping.

**Manual Shutoff Valve** — This manually-operated valve is used to seal the outlet of the tank during shipping or service. It should always be open when the vehicle is operating.

**Excess Flow Valve** — The excess flow valve is located in the supply fuel path. The valve is intended to shut off fuel flow from the tank in case the supply line comes off of the tank. If the excess flow valve trips (may happen after servicing the system), it can be reset by closing the manual shutoff valve and then slowly opening it.

**Pressure Relief Valve** — When conditions cause tank pressure to rise to 312 psi, this valve automatically opens to relieve the excessive pressure inside of the vehicle fuel tank. Propane vapor is vented out of the pressure relief hose.

**Fuel Supply Valve** — The fuel supply valve is controlled by the PCM and is activated whenever power is supplied to the fuel pump.

**Fuel Return Check Valve** — The fuel return line is protected by a check valve in the Multivalve which prevents fuel from flowing from the tank into the return line.

### FUEL LEVEL SENDING UNIT

The Fuel Level Sending Unit is located inside of the fuel tank and consists of a float on an arm with a wound resistor. The sending unit resistance is used by the instrument cluster to indicate fuel level and by the PCM. It is not used in the fill system.

## Fuel Filler Valve and Fill Line

The fuel fill line includes the fuel port with fill valve, the fill line hose and a filter.

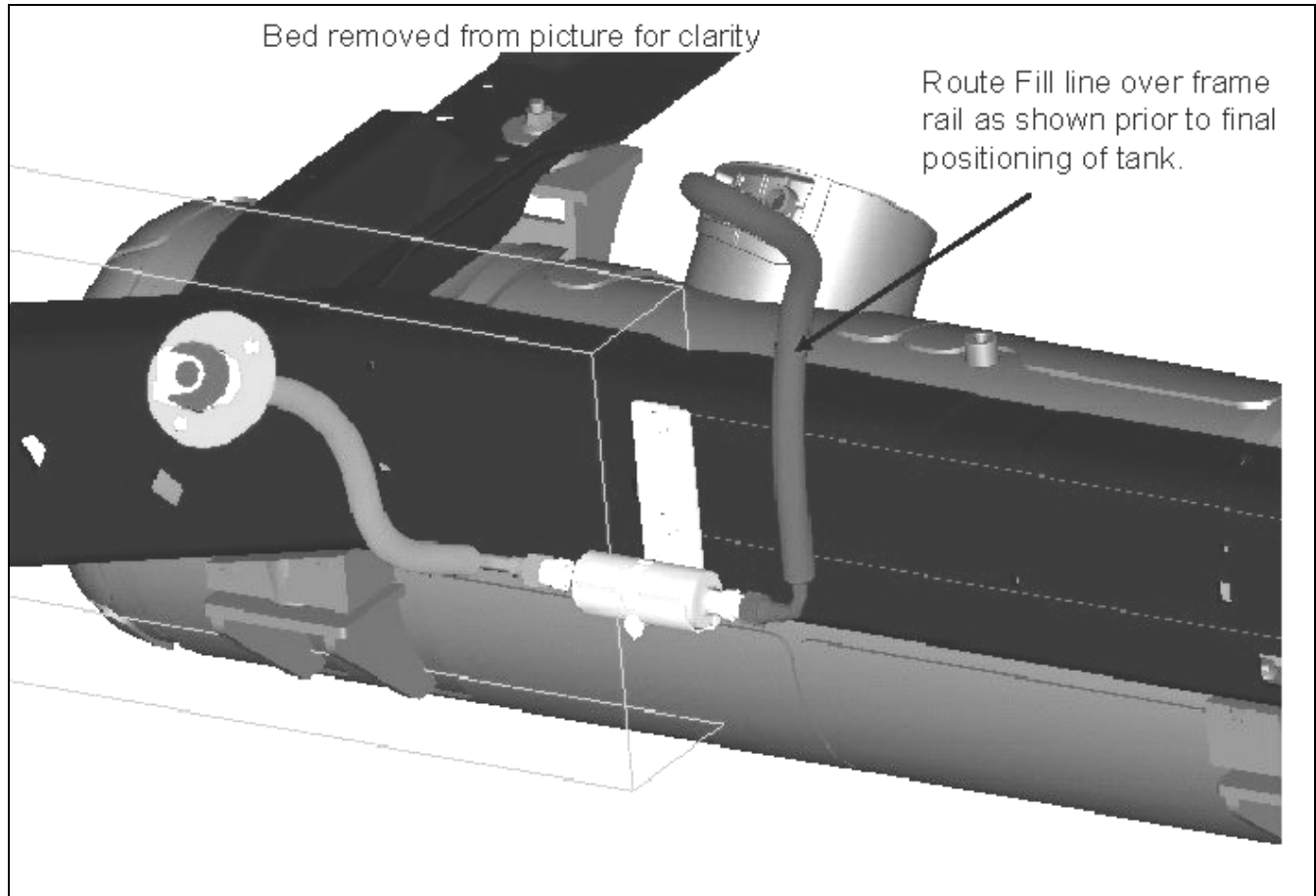

Figure 13 — Fuel Filler Neck, Fill Lines and Filter

### FILL VALVE

The Fill Valve serves as the fuel fill inlet to the vehicle fuel tank. This is where the fill station hose attaches while fueling and the fuel cap attaches during vehicle operation. It is a one way single back check valve that opens during the fuel fill process and closes when fueling is complete, to minimize fuel from escaping.

### IN-LINE FILTER

The fuel filter is located in the fuel fill line to filter fuel from the fill station before it enters the vehicle fuel tank. The filter is field serviceable and should be replaced every 50,000 miles.

## Glossary

**80% Level Sensor** — An infrared sensor designed to detect the presence of liquid. The sensor is located inside the vehicle fuel tank at the 80% full level.

**Bleed Solenoid** — Closed when the engine is running, sealing the fuel rail from the vehicle EVAP system. After the engine is turned off for approximately one hour, the Bleed Solenoid opens for a calibrated length of time allowing pressure to bleed from the fuel rails. When pressure is fully bled off, the solenoid closes, preventing fuel from entering the EVAP system. The bleed solenoid is located in the FRPCM.

**Fill Pressure Switch** — A normally open pressure sensing switch. The switch is attached to the Multivalve, internal to the vehicle fuel tank and used to sense pressure of the fuel coming into the vehicle fuel tank from the fill station.

**Fill Valve** — Located where fuel enters into the vehicle fuel tank. During the fill process, the valve is opened electrically by the Fuel Fill Solenoid. The valve also incorporates double back redundant check valves that close when vehicle fuel tank pressure is greater than the pressure outside of the tank to prevent fuel from escaping. The valve is part of the Multivalve.

**Fuel Control Solenoid** — Closed when the engine is running, but still allows fuel to flow through a metered orifice back to the vehicle fuel tank. The solenoid is opened for approximately 15 seconds after the engine is turned off to allow pressure in the fuel rails to return to the vehicle fuel tank. The solenoid may also be opened to flush the fuel rails to ensure that there is liquid fuel in the fuel rails during hot operating conditions. On F-Series vehicles, the solenoid is a separate unit mounted on the frame side rail.

**Fuel Fill Filter** — In-line between the Fill Valve and the fuel tank to filter fuel before entering the vehicle fuel tank during the fill process.

**Fuel Fill Solenoid** — Electrically-operated solenoid used to allow fuel to enter the vehicle fuel tank during fills. The solenoid is located inside of the vehicle fuel tank and is attached to the Multivalve.

**Fuel Level Sending Unit** — Located inside of the vehicle fuel tank to indicate fuel level. The unit consists of a float on an arm with a wound resistor.

**Fuel Rail Pressure Control Module (FRPCM)** — Module consisting of four normally closed solenoids controlled by a separate electronic control module. The FRPCM is mounted on the engine. The module is used only in E-Series vehicles.

**Fuel Return Check Valve** — Ensures fuel does not escape from vehicle tank if there is a leak in the fuel return line external to the tank. The valve is part of the Multivalve.

**Fuel Supply Valve** — Opened electrically by the Fuel Control Solenoid to provide fuel to the engine. Also incorporates an excess flow control valve to minimize fuel escaping if there is a leak in the fuel supply line external to the tank. The valve is part of the Multivalve.

**Injector Pressure and Temperature Sensor (IPTS)** — Mounted on the fuel rail, the IPTS is used to monitor pressure and temperature of the fuel.

**Manual Shutoff Valve** — Manually operated valve that is used to seal the outlet of the vehicle fuel tank during shipping or service. The valve should always be open when the vehicle is operating. The valve is part of the Multivalve.

## ROUSH® CleanTech F-250/F-350 Liquid Propane Injection Service Manual Supplement

---

**Multivalve** — Mounted directly on the vehicle fuel tank and serves as the main interface between fuel tank and vehicle. The Multivalve consists of five valves incorporated into one unit which includes the Fill Valve, the Manual Shutoff Valve, the Pressure Relief Valve, the Fuel Supply Valve and the Fuel Return Check Valve. Also attached to, but not part of the Multivalve, are the Fill Pressure Switch and the Fill Control Solenoid which are both internal to the tank.

**Pressure Relief Valve** — Automatically opens to relieve excessive pressure inside of the vehicle fuel tank. The valve is part of the Multivalve.

**Return Solenoid** — Open when the engine is running, the return solenoid allows fuel from the fuel rails to return to the vehicle fuel tank. The solenoid remains open for approximately 15 seconds after the engine is turned off, allowing pressure in the fuel rails to return to the vehicle fuel tank. The solenoid is part of the FRPCM.

**Fill Valve** — Serves as the fuel fill inlet to the vehicle fuel tank for attachment of the fill station hose. The valve is a one way single back check valve that opens during the fuel fill process and closes when fueling is complete to minimize fuel from escaping.

**Supply Solenoid** — Solenoid that is open (energized) when the engine is running, allowing fuel to flow from the vehicle fuel tank to the fuel rails. The solenoid is closed when the engine is turned off, preventing fuel from flowing from the vehicle fuel tank to the fuel rails. The solenoid is part of the FRPCM.

**Smart Relay Module** — Module that controls the actuation of the four solenoid valves in the fuel rail pressure control module.

## COMPONENT LOCATOR

### Engine Components

#### Fuel Rails and Injectors

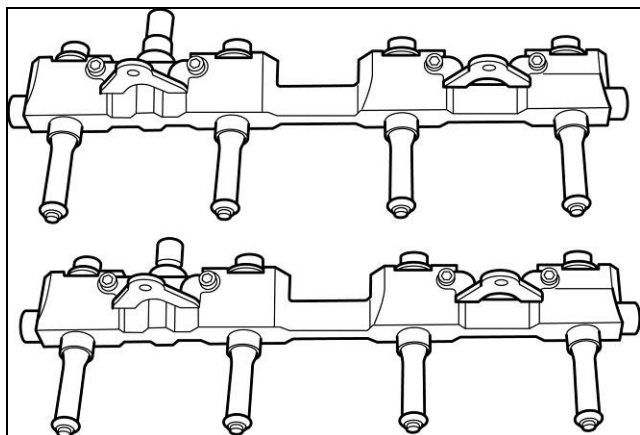

Figure 14 — Fuel Rails and Injectors

## Chassis

### Fuel Lines and Tanks

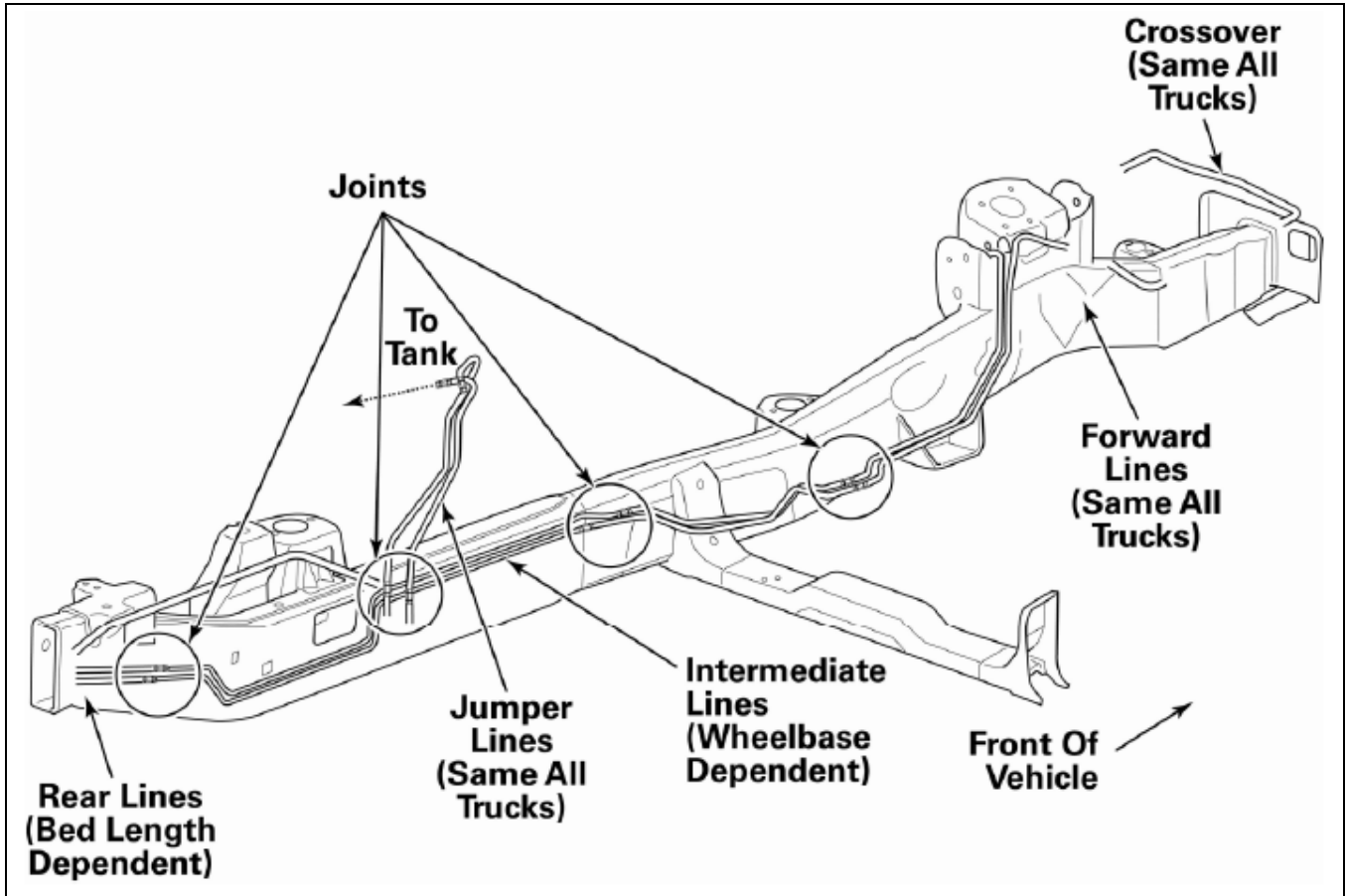

Figure 15 — Fuel Lines and Tank (Typical)

## TROUBLESHOOTING

### Symptom Tables

#### Fuel Odor

*(Content to be developed)*



## Diagnostic Flow Charts

### No Fill Condition

1. VERIFY VEHICLE BATTERY IS FULLY CHARGED AND CONNECTED.

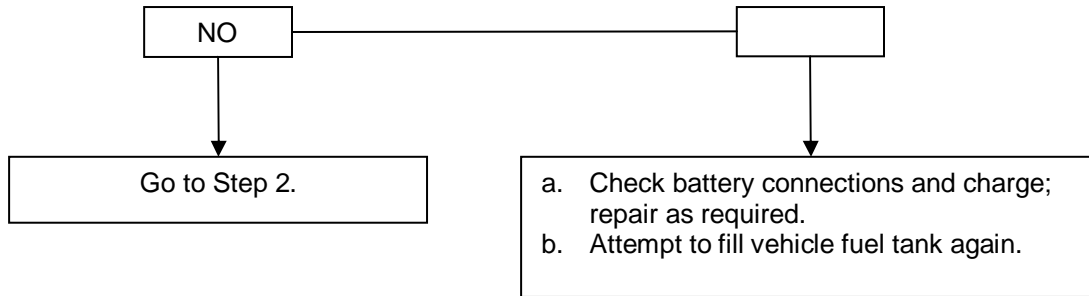

2. VERIFY THAT VEHICLE FUEL TANK IS ACTUALLY LOW ON FUEL AND NOT ALREADY FULL.

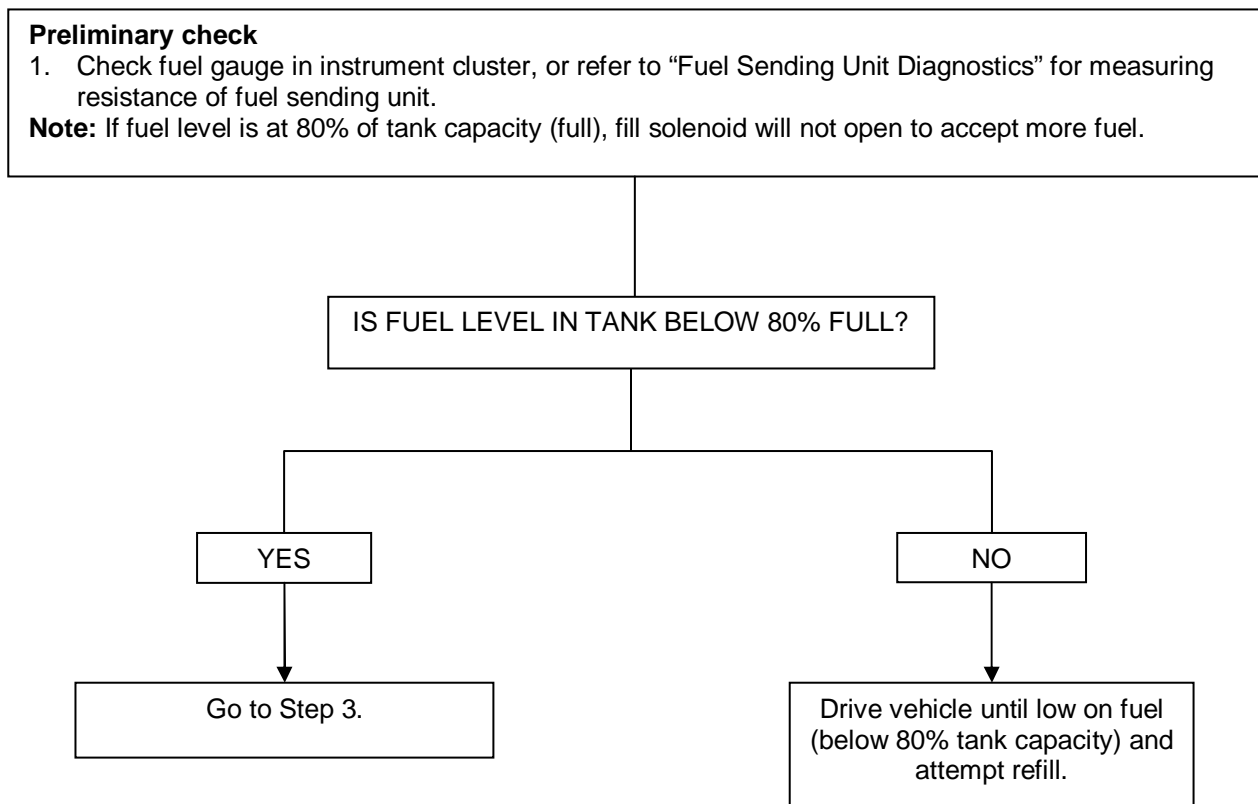

**ROUSH® CleanTech F-250/F-350 Liquid Propane Injection  
Service Manual Supplement**

---

**3. VERIFY THAT STATION FILL HOSE IS PROPERLY CONNECTED TO VEHICLE AND STATION IS OPERATING.**

**Procedure**

1. Connect pressure gauge (350 psi min) to bleeder valve on fuel tank.
2. Open bleeder valve and record gauge pressure reading.
3. Close bleeder valve.
4. Using propane safe gloves and safety glasses, carefully disconnect pressure gauge from bleeder valve making sure to relieve pressure in gauge hose very slowly.
5. Using the Fuel Fill Pressure Tester or equivalent, measure fill station pressure.
6. Compare fuel tank pressure to fill station pressure.

**Note:** Fill station pressure must be at least 50 psi greater than the vehicle fuel tank pressure or the tank will not fill.

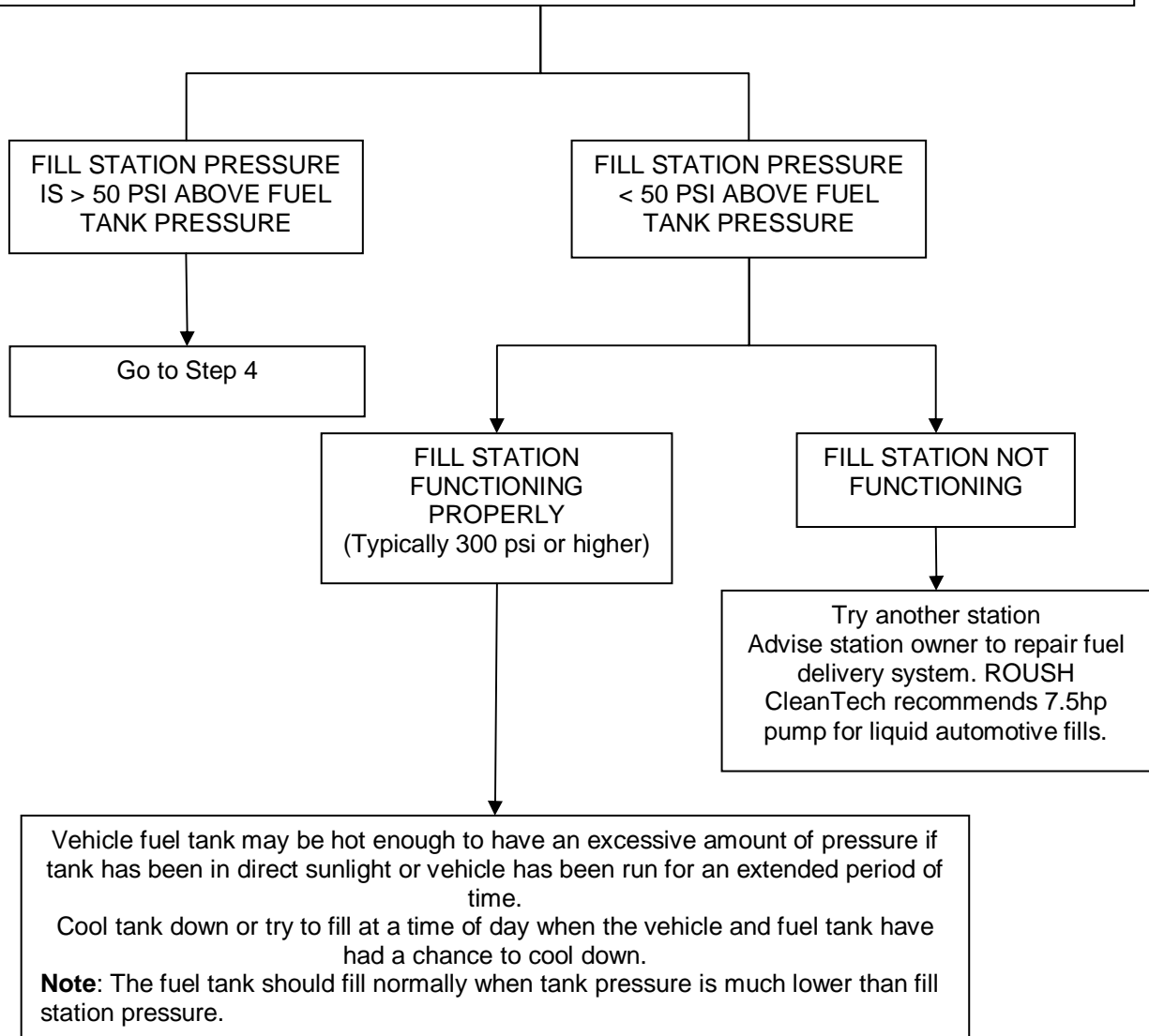

**ROUSH® CleanTech F-250/F-350 Liquid Propane Injection  
Service Manual Supplement**

**4. VERIFY THAT THERE IS 12-VOLT BATTERY POWER TO FUEL TANK FILL CIRCUIT AND POLARITY IS CORRECT.**

**Procedure**

1. Turn the ignition switch to the off position if not already done.
2. Disconnect the 6-wire fuel tank harness connector (located on wire loom from fuel tank) from the vehicle harness.
3. Connect a voltmeter positive lead from the Blue wire (Pin A positive), and the negative lead to the plain Black wire (Pin D negative) on the vehicle side of the 6-wire connector or utilize the Fuel Tank Breakout Box (see guide provided with the breakout box).
4. Check the voltmeter reading. The voltmeter should indicate battery voltage (12 volts) and also indicate proper polarity.

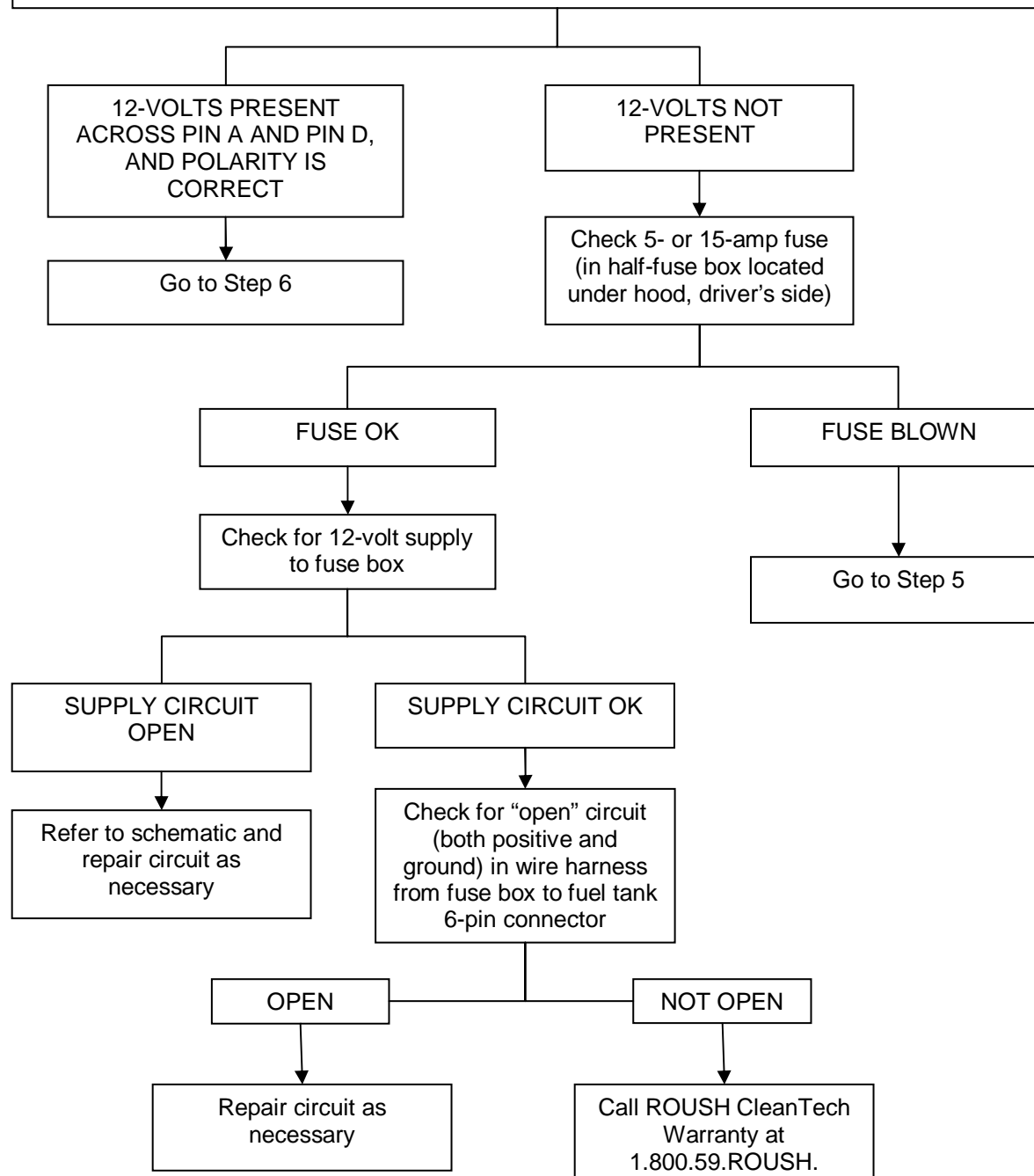

**ROUSH® CleanTech F-250/F-350 Liquid Propane Injection  
Service Manual Supplement**

**5. CHECK FOR SHORT CIRCUIT IN 12-VOLT SUPPLY TO FUSE BOX.**

**Procedure**

1. Verify ROUSH wire harness isn't damaged.
2. Pin out to make sure short isn't in the harness.

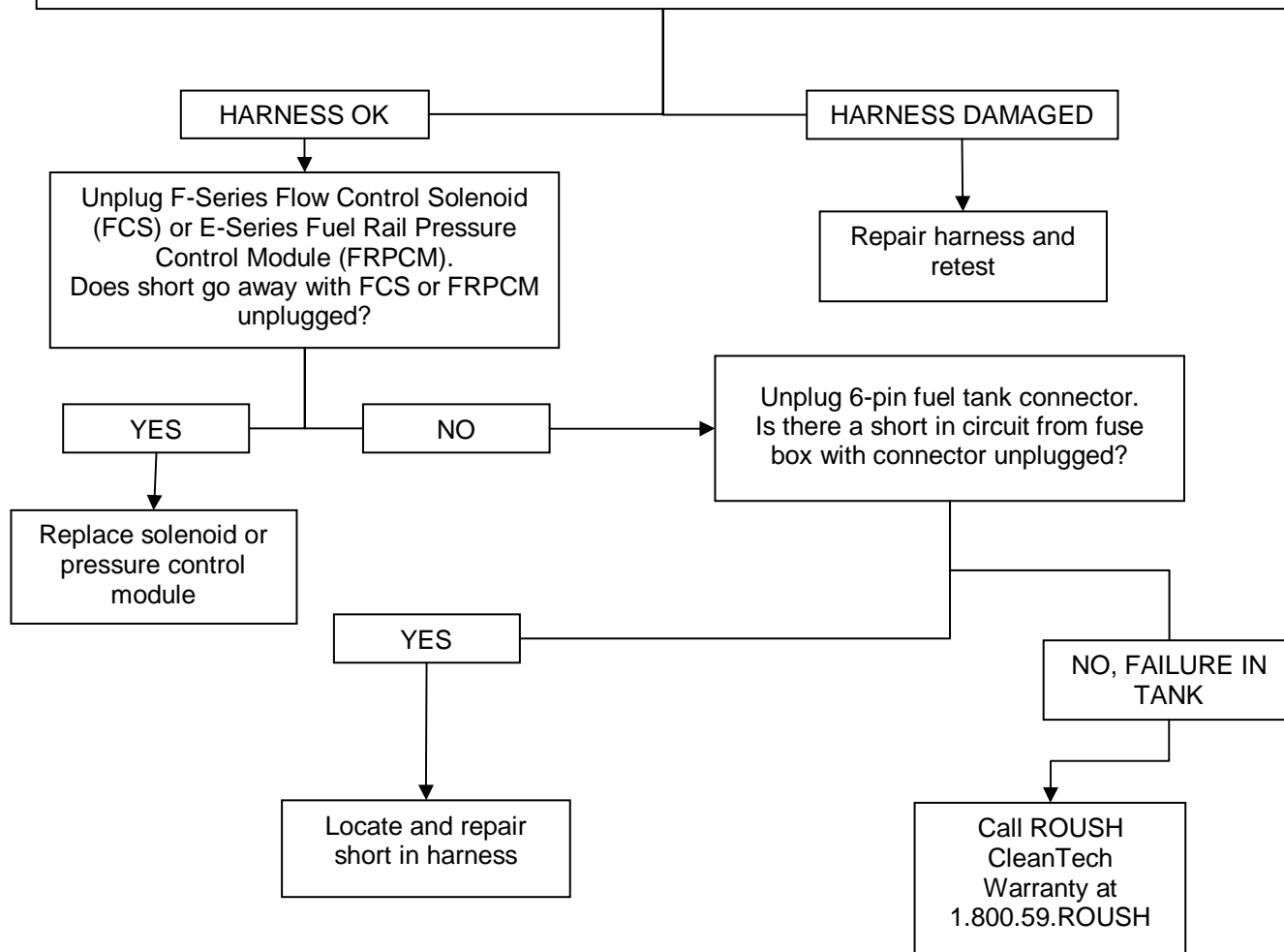

**ROUSH® CleanTech F-250/F-350 Liquid Propane Injection  
Service Manual Supplement**

---

**6. VERIFY THAT THE 6-PIN FUEL TANK CONNECTOR AND HARNESES TO THE FUEL TANK ARE UNDAMAGED AND OK.**

**Visual Inspection**

1. Are terminals in the tank side of the 6-pin connector straight and properly positioned?
2. Are wires between connector and fuel tank undamaged and in good condition?
3. Do wire color codes match on both vehicle and tank side of all connectors from the fuse box to the fuel tank?
4. Check that all wire crimps are made properly and that there are no loose connections.

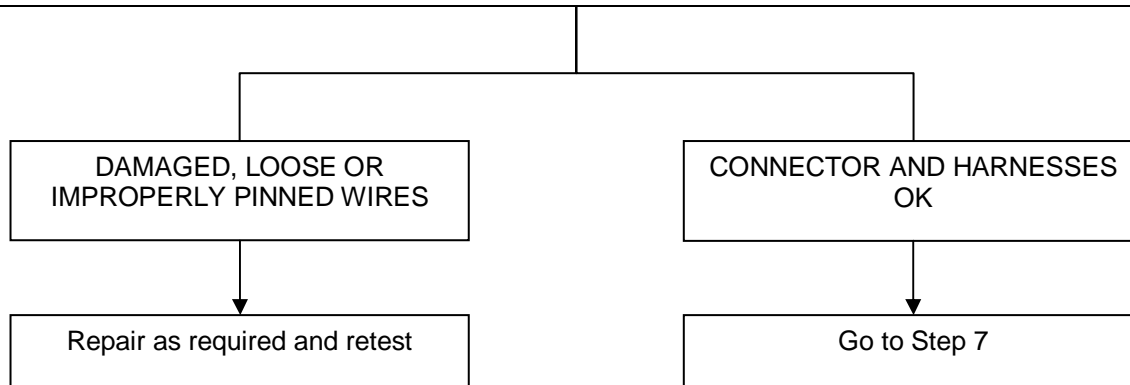

**7. RECONNECT 6-PIN CONNECTOR AND MEASURE CURRENT TO TANK FILL CIRCUIT.**

Refer to wire harness drawing in Section 9, SCHEMATICS, specific to the vehicle you are diagnosing. Locate the 5-amp (E-Series) or 15-amp (F-Series) fuse for the "fill" circuit.

**Procedure**

1. Remove 5-amp or 15-amp fuse from mini-fuse holder in half fuse box under hood, driver's side.
2. Connect an ammeter across terminals in fuse holder.
3. Attempt to fill tank while watching ammeter (Fill circuit will only activate when pump pressure is supplied to the filler).

**Note:** Ammeter should read 0.7–0.95 amps if fuel fill circuit is activated. If ammeter reads near 0 amps, the fuel fill circuit is not activated and tank will not fill.

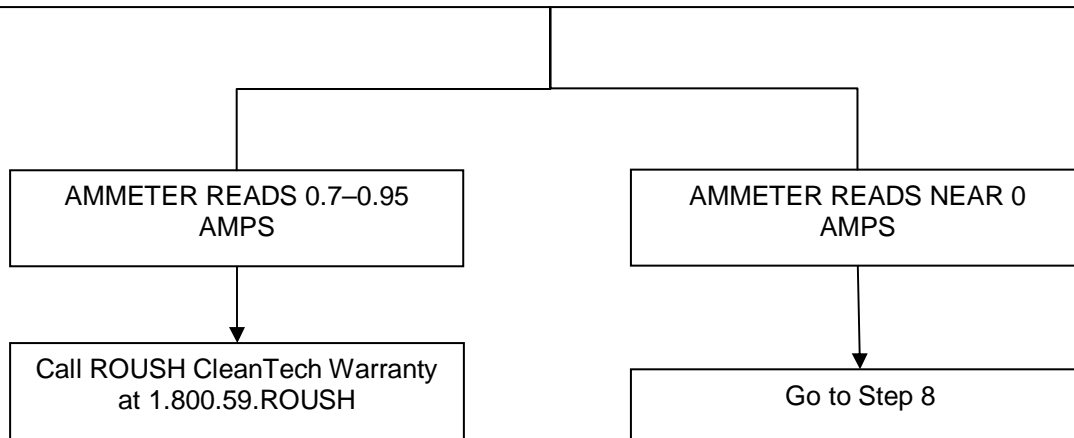

**ROUSH® CleanTech F-250/F-350 Liquid Propane Injection  
Service Manual Supplement**

---

**8. CHECK FOR RESTRICTIONS IN THE FUEL FILL SYSTEM.**

**Procedure**

1. Check for kinks or restrictions in the tank blue fill hose.
2. Verify that the fuel filter is not plugged.
3. Verify that the Fill Valve is functioning properly.

**Note:** If any of the above problem conditions exist, the fuel fill switch will not close and will prevent the tank from filling.

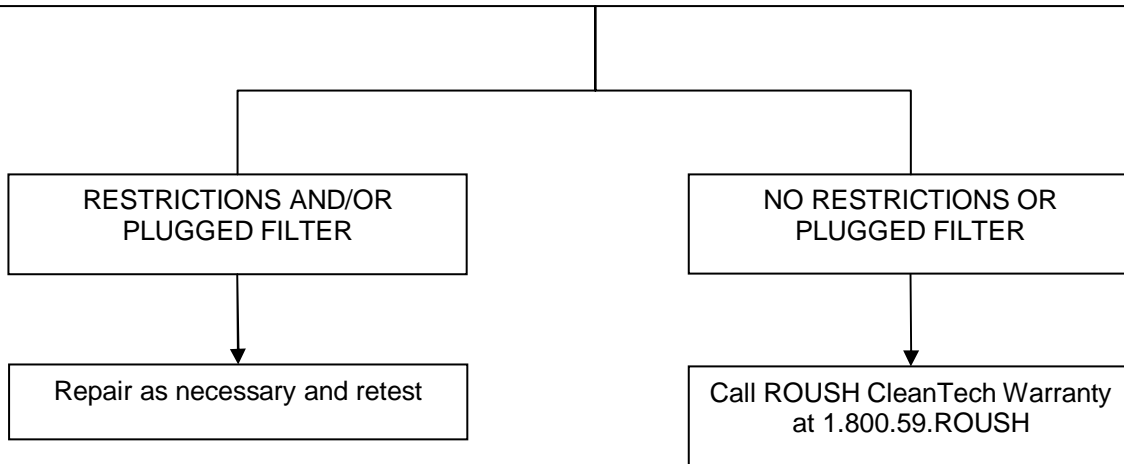

**ROUSH® CleanTech F-250/F-350 Liquid Propane Injection  
Service Manual Supplement**

**Slow Fill Condition**

1. VERIFY VEHICLE BATTERY IS FULLY CHARGED AND CONNECTED.

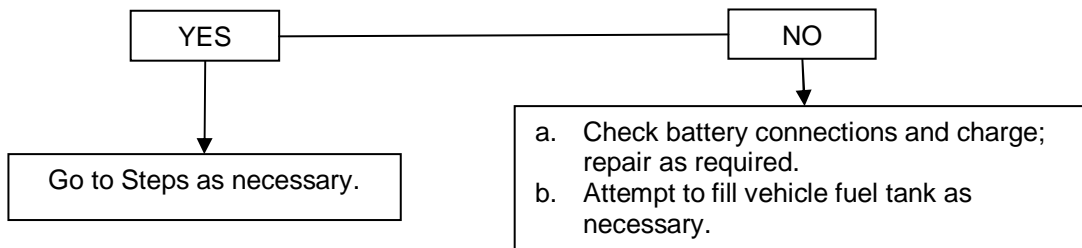

2. VERIFY THAT FILL STATION PRESSURE IS AT LEAST 50 PSI GREATER THAN VEHICLE TANK PRESSURE.

**Preliminary check**  
If this is the first fill after vehicle assembly or major fuel system repair, follow ROUSH CleanTech service “Flush and Fill Procedure for New Tank”.

**Note:** If fill is **EXTREMELY slow (less than 0.2 gallons per minute)** and fill station pressure is **acceptable (>50 PSI over tank)**, it may indicate that the fill circuit is not activated. Follow “No-Fill Condition” diagnostic.

**Procedure**

1. Attach pressure gauge (350 psi minimum) to bleeder valve on vehicle fuel tank.
2. Compare tank pressure reading to fill station pressure.
3. Record vehicle tank and fill station pressure readings for reference.

**Note:** Fill station pressure must be at least 50 psi greater than tank pressure. If not, fuel tank may not fill or will fill slowly.

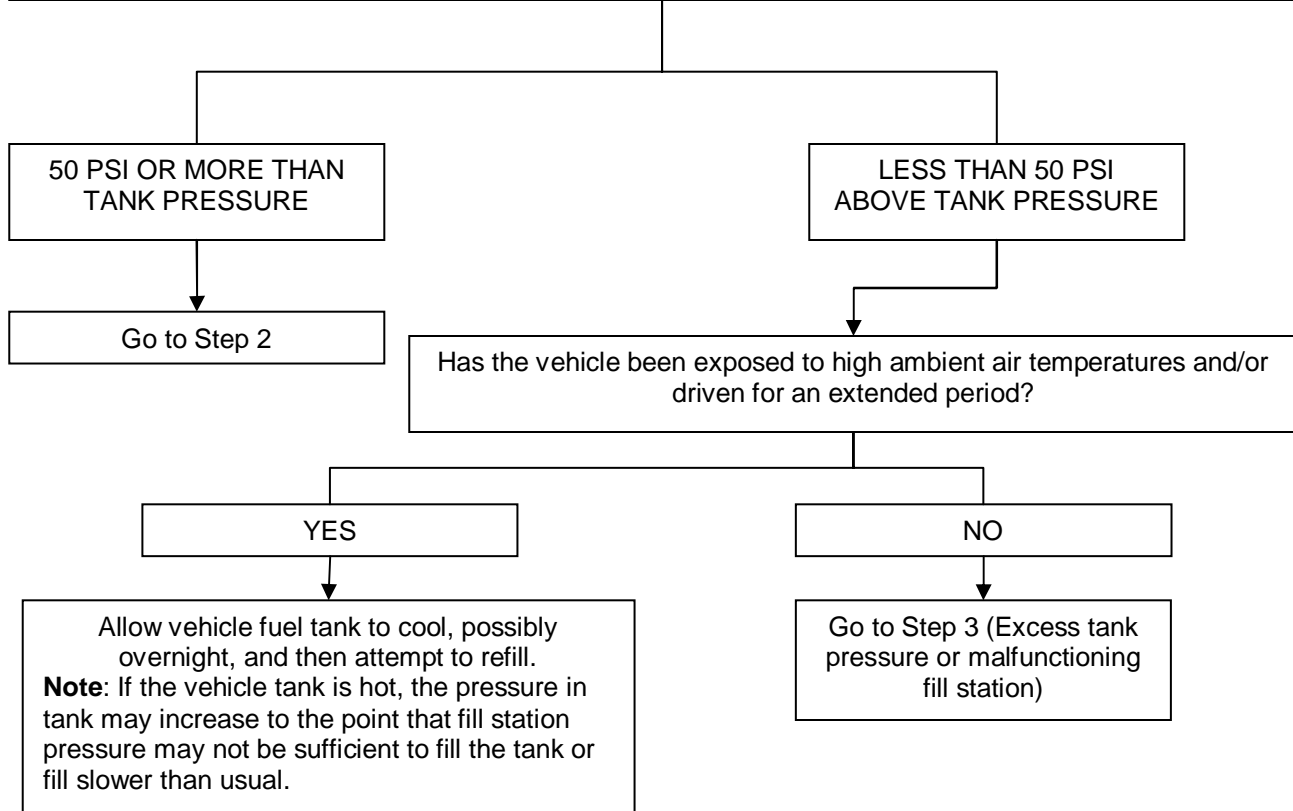

3. CHECK FOR RESTRICTIONS IN THE FUEL FILL SYSTEM.

**Procedure**

1. Check for kinks or restriction in the tank blue fill hose.
2. Verify that the fuel filter is not plugged.
3. Verify that the Fill Valve is functioning properly.

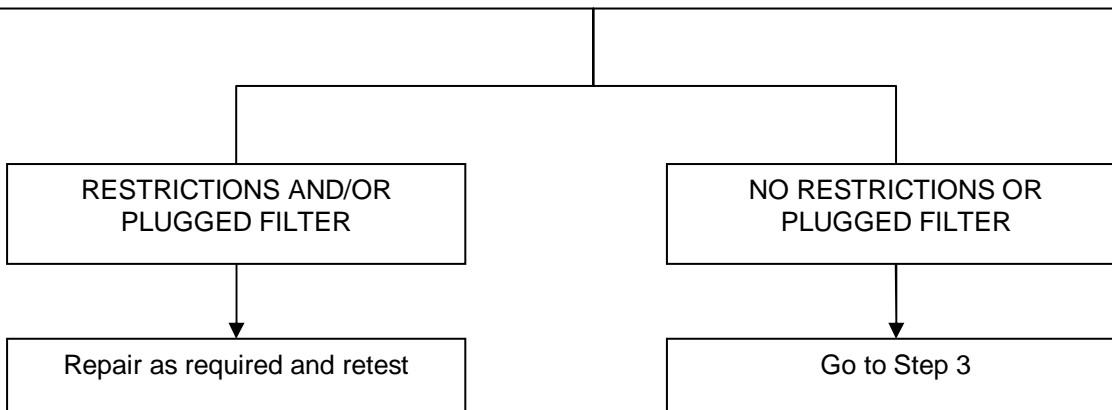

4. CHECK CURRENT FLOW TO THE TANK FILL CIRCUIT

Refer to wire harness drawing in Section 9, SCHEMATICS, specific to the vehicle you are diagnosing. Locate the 5-amp (E-Series) or 15-amp (F-Series) fuse for the "fill" circuit.

**Procedure**

1. Remove 5-amp or 15-amp fuse from mini-fuse holder in half fuse box under hood, driver's side.
2. Connect an ammeter across terminals in fuse holder.
3. Attempt to fill tank while watching ammeter.

**Note:** Ammeter should read 0.7–0.95 amps if fuel fill circuit is activated. If ammeter reads near 0 amps, the fuel fill circuit is not activated and tank will not fill.

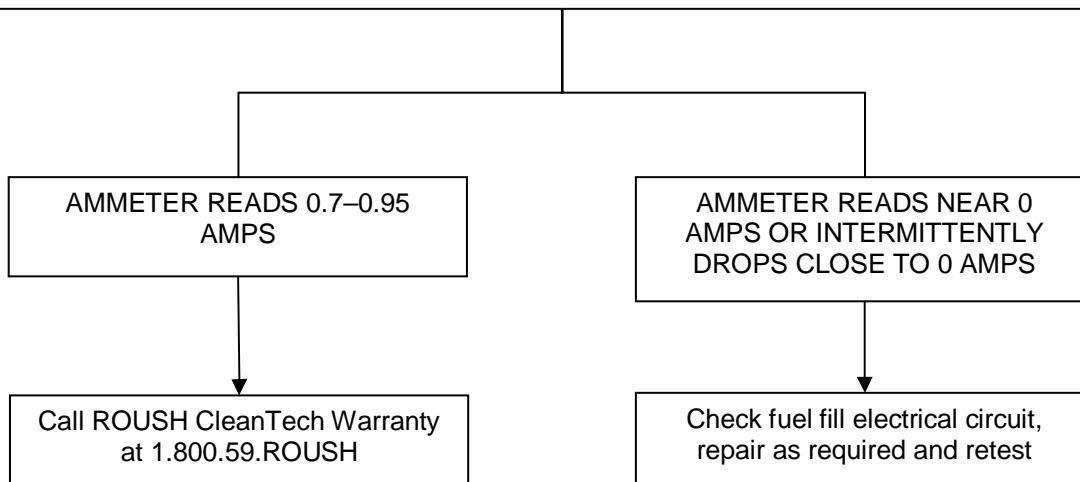



ROUSH® CleanTech F-250/F-350 Liquid Propane Injection  
Service Manual Supplement

**No Start Condition**

1. VERIFY VEHICLE BATTERY IS FULLY CHARGED AND CONNECTED.

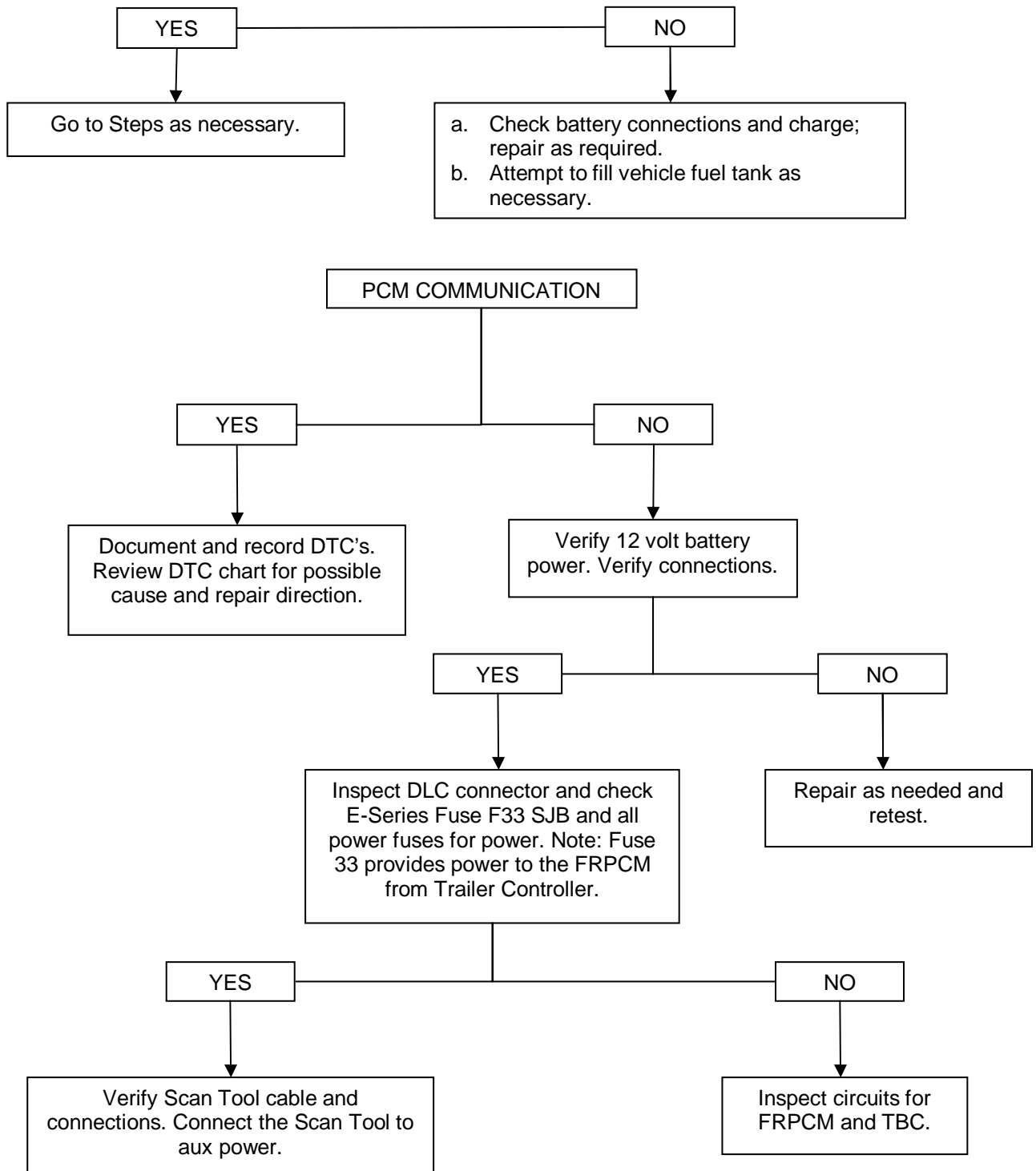

## Fuel Pump Diagnostics

### 1. VERIFY VEHICLE BATTERY IS FULLY CHARGED AND CONNECTED.

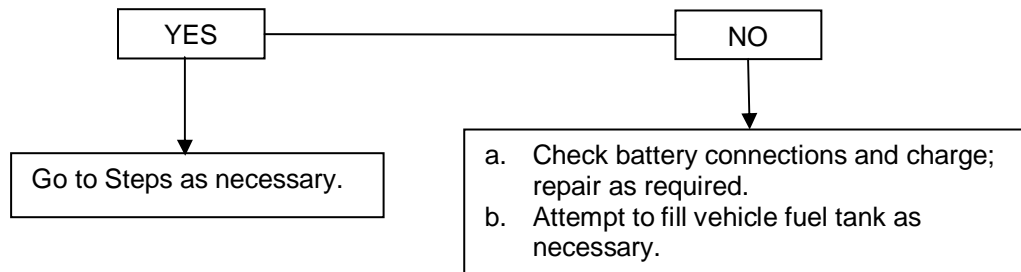

### 2. GENERAL INFORMATION

The fuel pump should run continuously when the engine is cranking or running. The ROUSH CleanTech fuel pump relay in the mini relay box is controlled by the original Ford fuel pump circuitry including the Fuel Pump Driver Module and the Inertia Switch or Fuel Pump Interrupt software. It is virtually the same as the production Ford circuit except for the addition of a separate fuel pump relay, fuel pump fuse and ROUSH CleanTech wire harness to the fuel pump.

To verify that the fuel pump is operating properly, use the following procedure starting with Step 3.

### 3. CHECK FUEL PUMP OPERATION

#### Procedure

1. Turn ignition switch to start position and wait for engine to crank.
2. Listening closely at fuel tank, can fuel pump be heard running when the engine cranks?

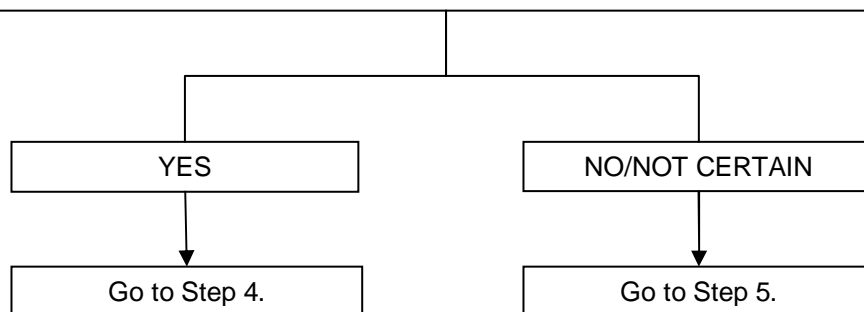

ROUSH® CleanTech F-250/F-350 Liquid Propane Injection  
Service Manual Supplement

4. CHECK FUEL PUMP PRESSURE

**Procedure**

1. Connect pressure gauge (350 psi min) to bleeder valve on fuel tank.
2. Open bleeder valve and record gauge pressure reading for reference.
3. Close bleeder valve.
4. Using propane safe gloves and wearing safety glasses, carefully disconnect pressure gauge from bleeder valve making sure to relieve pressure in gauge hose very slowly.
5. Connect pressure gauge (350 psi min) to fuel rail.
6. Turn ignition switch to start position – wait for engine to crank.
7. Measure pressure at fuel rail when engine begins to crank or run. Compare fuel rail pressure with fuel tank pressure. Fuel rail pressure should be at least 50 psi higher than fuel tank pressure.

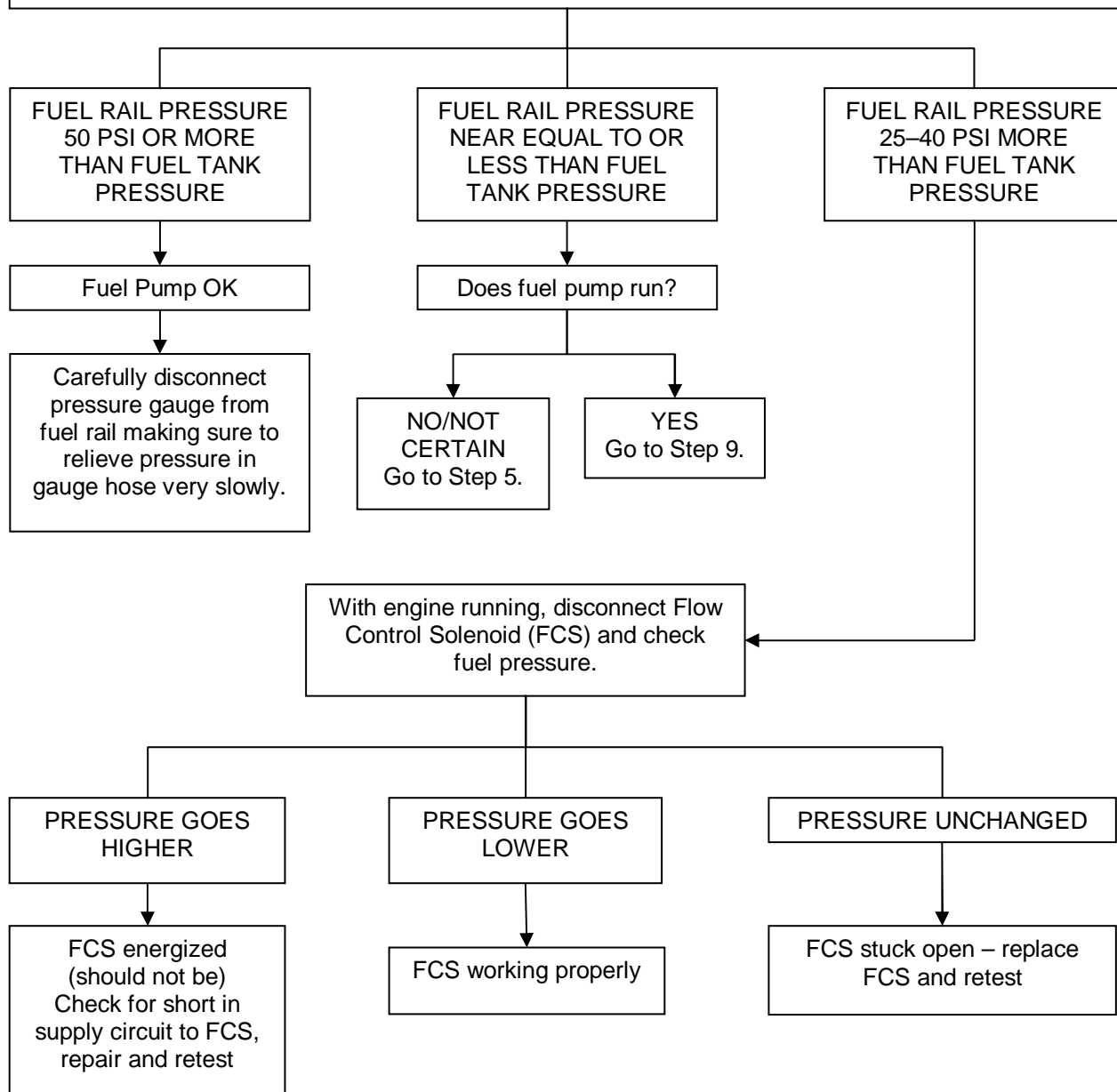

## ROUSH® CleanTech F-250/F-350 Liquid Propane Injection Service Manual Supplement

### 5. CHECK MULTIVALVE SOLENOID ACTUATION

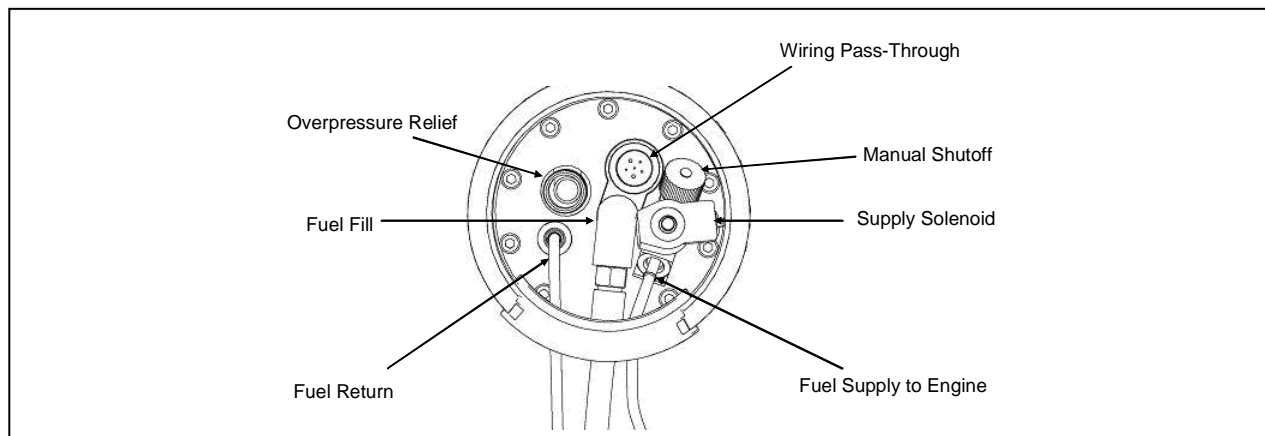

**Figure 16 — Multivalve**

#### Procedure

1. Turn ignition switch to off position if not already done.
2. Disconnect 6-pin fuel tank harness connector (located on wire loom at fuel tank) from vehicle harness.
3. Connect positive lead of voltmeter to the Pink/Black wire (Pin xx), and negative lead to the Brown/White wire (Pin xx) on vehicle side of harness connector.
4. Turn ignition switch to start position, release and wait for engine to crank.
5. Check voltmeter reading when engine begins to crank. Voltmeter should indicate battery voltage (12 volts) across the two wires.

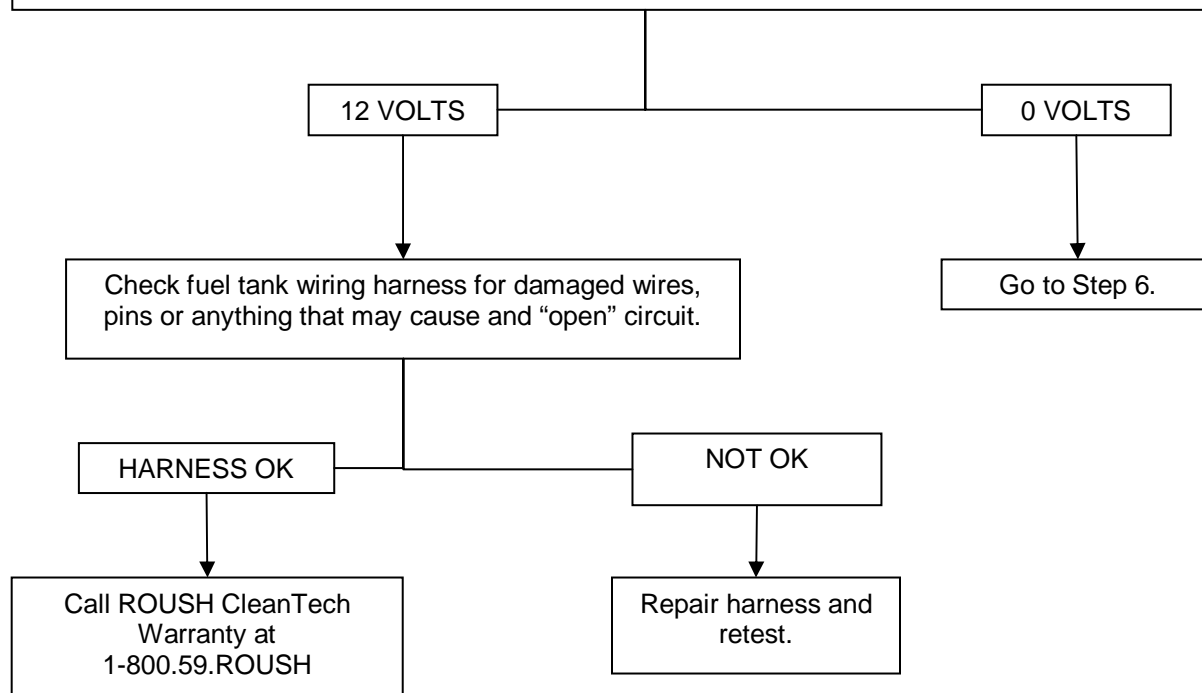

6. CHECK 20-AMP FUSE

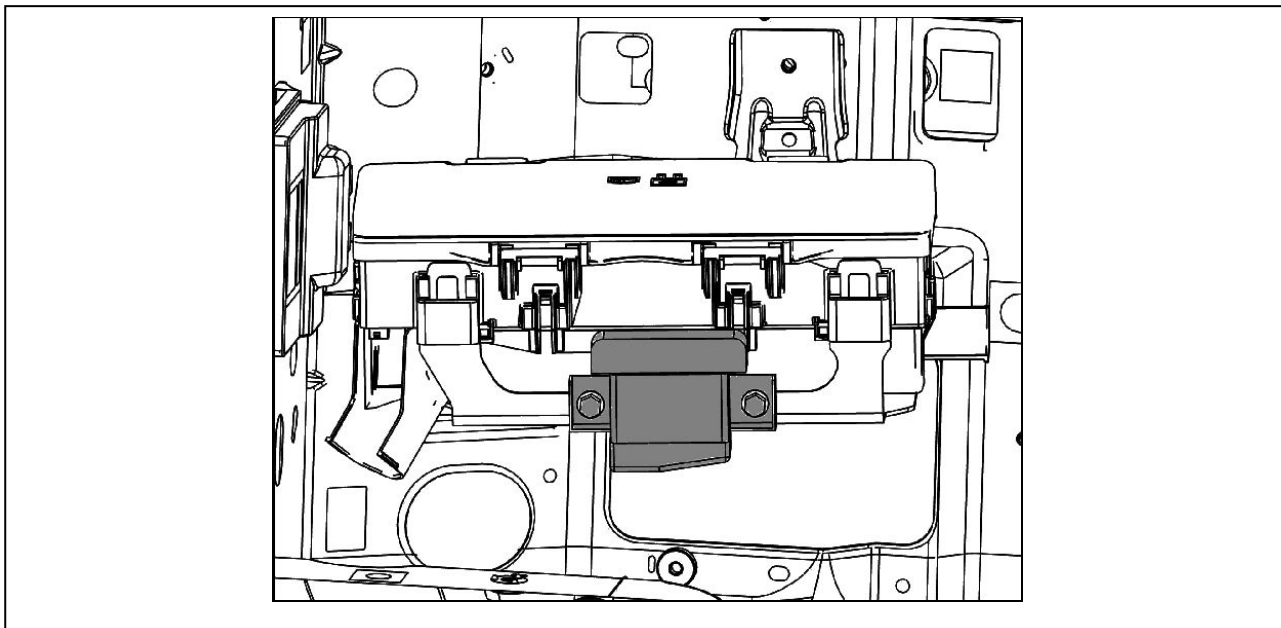
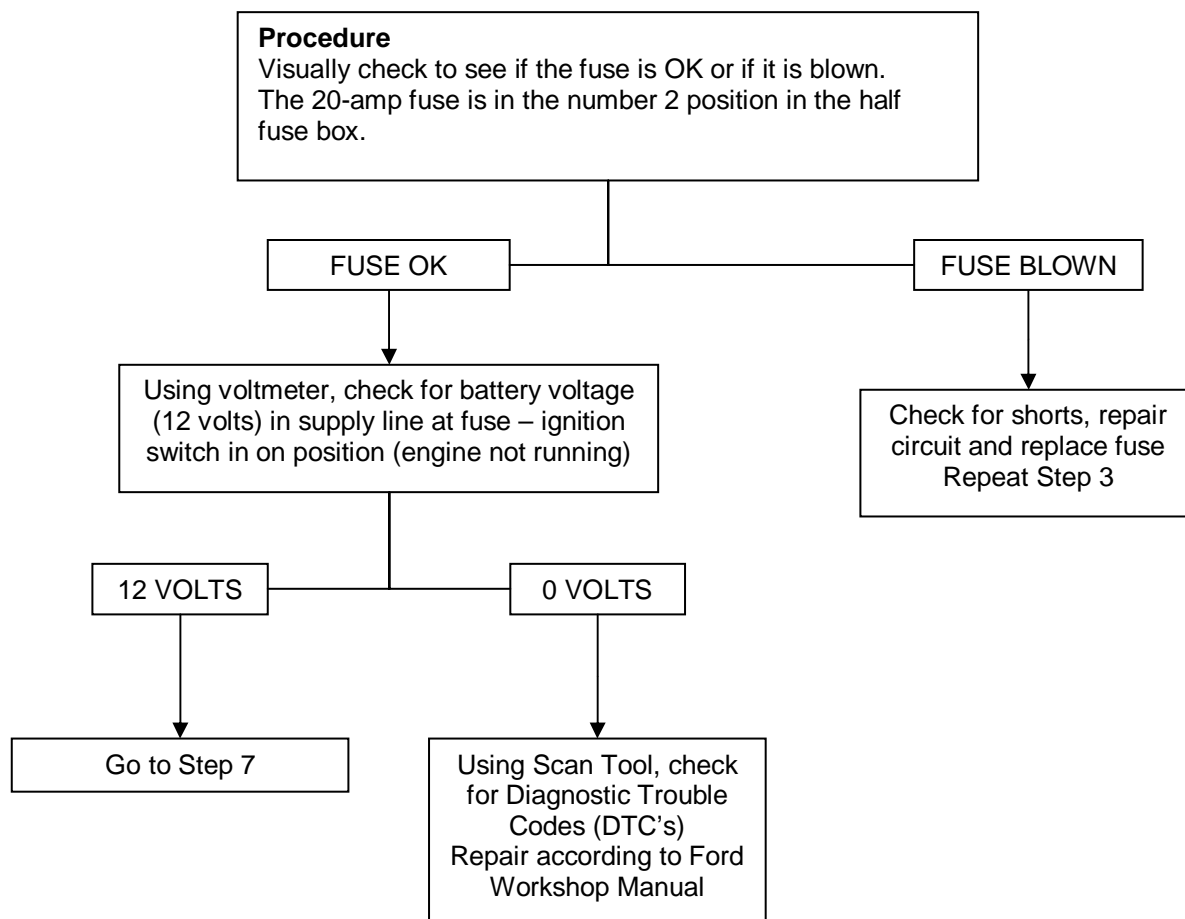

Figure 17 — Half-Fuse Box



**7. CHECK FUEL PUMP RELAY FUNCTION**

Check fuel pump relay function per the Ford On-line Workshop Manual and wiring diagrams.

**8. CHECK FUEL PUMP RELAY SUPPLY CIRCUIT**

Check fuel pump relay function per the Ford On-line Workshop Manual and wiring diagrams.

# ROUSH® CleanTech F-250/F-350 Liquid Propane Injection Service Manual Supplement

## 9. CHECK MANUAL VALVE OPERATION

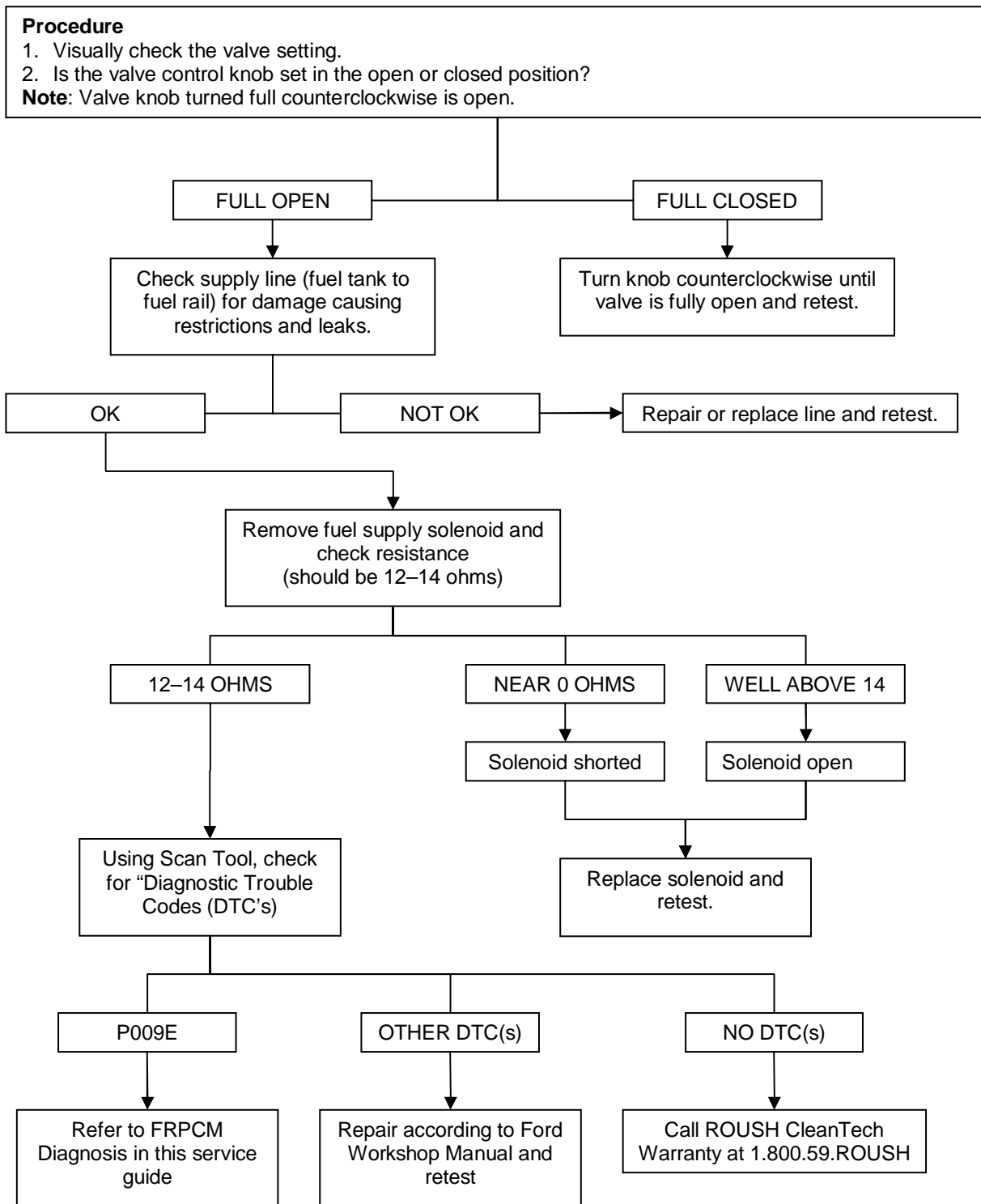

### Fuel Sending Unit Diagnostics

1. VERIFY VEHICLE BATTERY IS FULLY CHARGED AND CONNECTED.

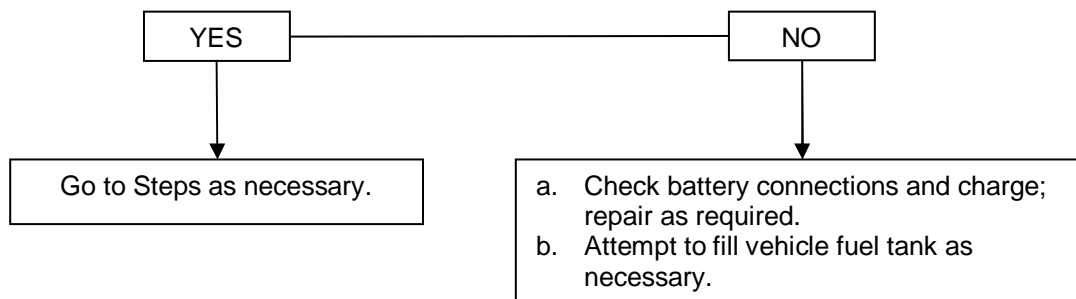

2. VOLT POWER TO FUEL SENDING UNIT.

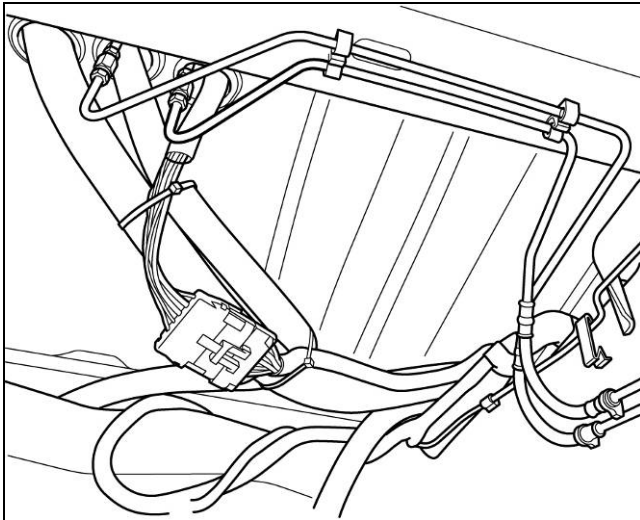

Figure 18 — 6-Pin Harness Connector (Vehicle Side)



## ROUSH® CleanTech F-250/F-350 Liquid Propane Injection Service Manual Supplement

---

### Procedure

1. Turn the ignition switch to the off position if not already done.
2. Disconnect the 6-pin fuel tank harness connector (located on fuel tank wire loom) from the vehicle harness.
3. On the vehicle side of the 6-pin connector, connect positive lead of voltmeter to the Yellow wire (Pin E positive), and negative lead to the Black/Orange wire (Pin F negative).
4. Check the voltmeter reading. The voltmeter should indicate battery voltage (12 volts) and also indicate proper polarity.

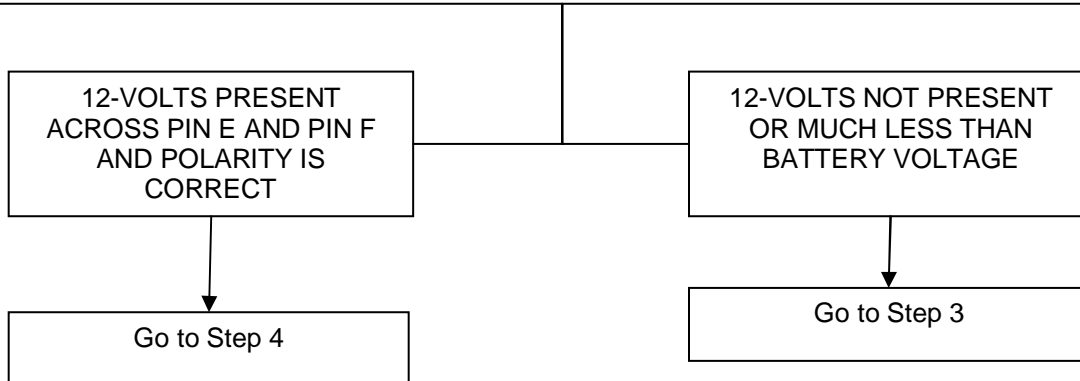

ROUSH® CleanTech F-250/F-350 Liquid Propane Injection  
Service Manual Supplement

3. CHECK FOR 12-VOLT POWER AT THE 4-PIN CONNECTOR.



Figure 19 — ROUSH CleanTech-to-Ford 4-Pin Harness Connector (Typical)

**Procedure**

1. With the ignition switch in the off position, disconnect the 4-pin connector where the ROUSH CleanTech harness attaches to the Ford vehicle harness.
2. Using the voltmeter on the Ford harness side of the connector, place the positive lead on the Yellow wire terminal and the negative lead on the Black/Orange wire terminal.
3. Check for battery voltage (12 volts) across the terminals.

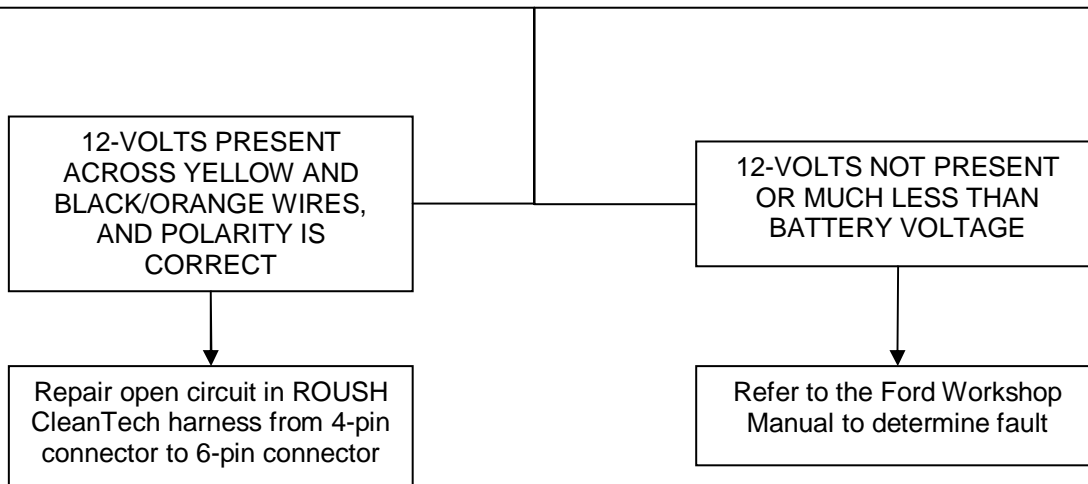

**ROUSH® CleanTech F-250/F-350 Liquid Propane Injection  
Service Manual Supplement**

**4. CHECK RESISTANCE ACROSS TERMINALS OF FUEL SENDING UNIT**

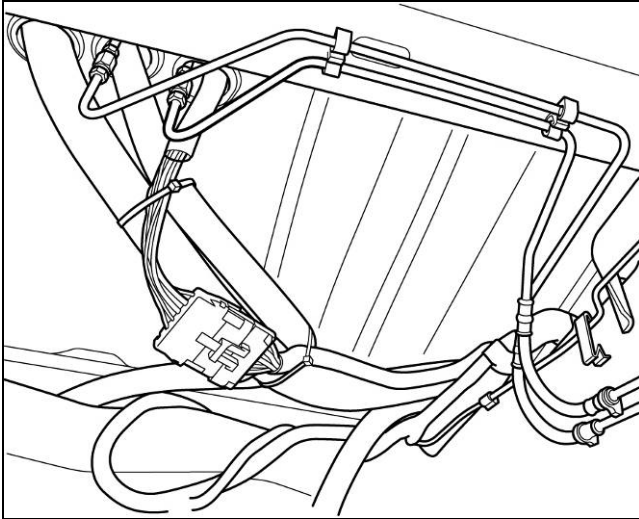

**Figure 20 — Fuel Sending Unit 6-Pin Connector Terminals**

**Procedure**

1. Place positive probe of ohmmeter on Yellow wire (Pin E) and negative probe on Black / Orange wire (Pin F).
2. Measure resistance across the terminals and check resistance reading against the Fuel Fill Table below for fuel level in vehicle being tested.

**Note:** The measured resistance should indicate the amount of fuel in the tank.

**Fuel Fill Table**

Model, Tank Configuration	Resistance (ohms)				
	Full	3/4	1/2	1/4	Empty
F-250/F-350 In Bed	17	32.6	55.7	86.8	160
F-250/F-350 Under Vehicle	21.3	31.5	60	90	160

## MAINTENANCE REQUIREMENTS

### Schedule

With the exception of the fuel system, follow the Ford Maintenance Schedules and Workshop Manual for all F-Series maintenance requirements.

For the ROUSH CleanTech LPI fuel system, refer to the schedule and procedures below.

Operation	Maintenance Interval
In-line Fuel Filter Replacement	50,000 miles (80,000 km)

## MAINTENANCE PROCEDURES

### Intake Air Filter Inspection

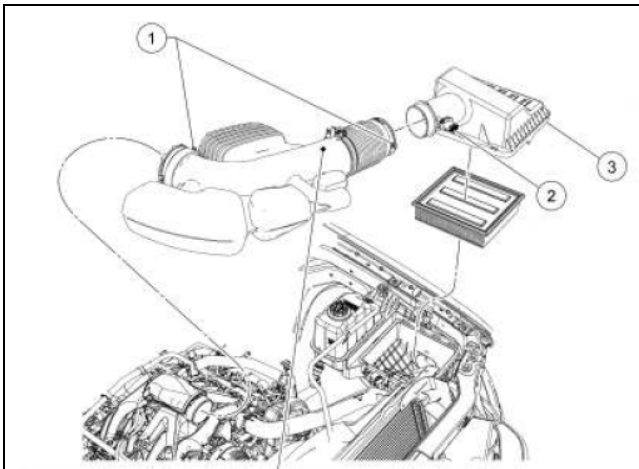

Figure 21 — Intake Air Tube Assembly and Filter Housing (Typical)

- |                |                            |
|----------------|----------------------------|
| 1. Hose Clamps | 3. Intake Air Box<br>Cover |
| 2. MAF Sensor  |                            |

This intake air filter assembly is unique to the F-250/F-350 and is necessary for the ROUSH CleanTech LPI system. All other applications intake air filter assembly is common to base Ford vehicles. Consult the appropriate Ford Work Shop Manual for service.

## In-Line Fuel Filter Replacement

**▲ Danger** — A trace amount of propane fuel will be released on loosening the fittings. It will settle to the lowest available surface before it dissipates into the atmosphere. Keep heat, sparks, flames, static electricity or other sources of ignition out of the area when venting or purging the fuel lines or tank. Failure to heed this danger can result in severe personal injury or property damage.

1. Purge residual fuel from the fuel fill line.
2. Disconnect the fuel fill line from the fuel filter inlet.
3. Disconnect the fuel fill line from the fuel filter outlet.

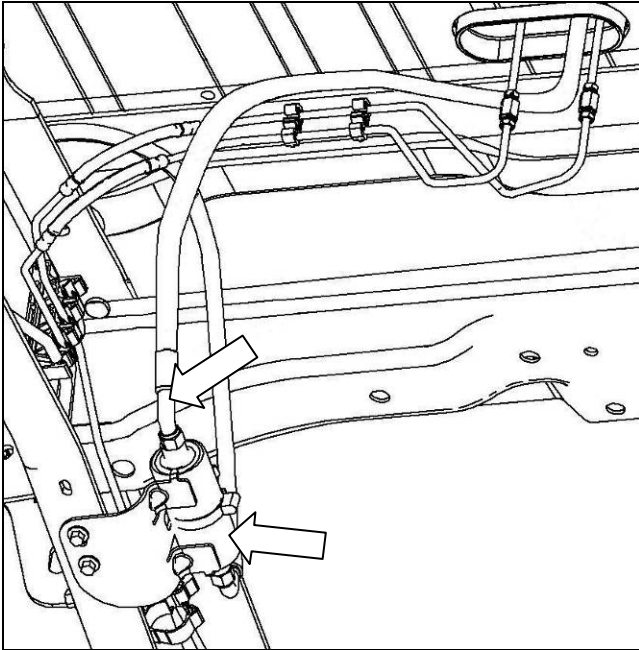

**Figure 22 — In-Line Fuel Filter (Typical)**

4. Loosen the clamp retaining the fuel filter in place.
5. Remove and discard the filter.
6. Place a new fuel filter in position on the filter bracket and tighten the retaining clamp to 4–5 N•m (35–44 lb-in).
7. Connect the fuel file lines to the filter inlet and outlet. Tighten the line fittings to 41–49 N•m (30–36 lb-ft).

## REPAIR PROCEDURES

### Preparing Vehicle for Service

#### Alert Messages

The following alert messages appear from time to time in appropriate places in this manual. Ensure that all personnel in the immediate area are aware of these reminders.

**▲ Danger** — Propane is nontoxic, nonpoisonous, has the lowest flammability range of any alternative fuel and dissipates quickly when released into the atmosphere. Propane vapor is heavier than air and seeks the lowest point. When the ratio of propane to air is between 2.2% and 9.6%, propane burns in the presence of an ignition source at 940°F (504°C)<sup>1</sup> or hotter. Keep away from heat, sparks, flames, static electricity or other sources of ignition. Failure to heed this danger can result in severe personal injury.

**▲ Danger** — Fuel supply lines remain pressurized after engine shutdown. Keep away from heat, sparks, flames, static electricity or other sources of ignition. Do **NOT** enter storage areas or confined spaces unless they are adequately ventilated. Failure to heed this danger can result in severe personal injury.

**▲ Danger** — Propane is heavier than air and seeks the lowest available level when released to the atmosphere. Keep heat, sparks, flames, static electricity or other sources of ignition out of the area when venting or purging the fuel lines or tank. Failure to heed this danger can result in severe personal injury or property damage.

**▲ Warning** — Liquid propane is cold. The temperature of propane in its liquid state is -44°F (-42°C). Wear eye and ear protection during venting and repair operations. Keep moisture away from the valves. Failure to heed this warning can result in personal injury.

**Note** — Identify the condition (good, stuck open, stuck closed or inoperable) of each solenoid valve prior to venting the fuel tank to ensure that the solenoid valves are not the reason for vehicle service and unnecessarily venting the tank.

---

<sup>1</sup> Gasoline auto-ignition occurs at a much lower temperature: 430°–500°F (221°–260°C).

## Changing Fuses

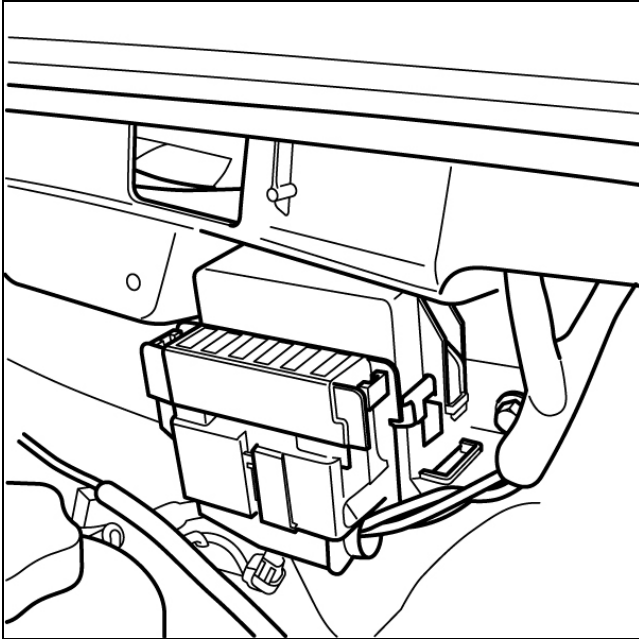

Figure 23 — Fuse Panel

The fuse panel is located on the bulkhead under the hood on the driver's side.

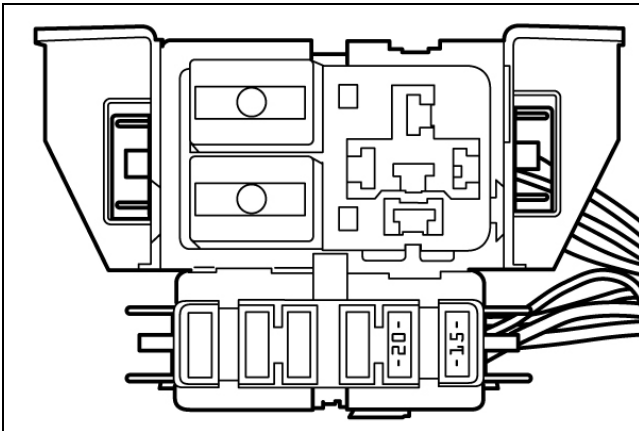

Figure 24 — 20 Amp and 15 Amp Fuses

Always use a fuse of the correct amperage when replacing fuses.

## Pressure Relief

There are two means of relieving excess pressure in the tank; the pressure relief valve in the Multivalve and the bleeder valve in the tank wall that is separate from the Multivalve.

The pressure relief valve in the Multivalve vents excess pressure to the atmosphere through a hose that directs the release to a point at the bottom of a rear wheel opening. The pressure relief hose clamps to an elbow that attaches the cover to the Multivalve. The pressure relief hose, elbow and Multivalve cover are removable while the tank is in the vehicle.

The bleeder valve in the tank wall vents immediately to the atmosphere. This valve can also be serviced using a standard box end wrench while the tank is in the vehicle.

## Purging

Clearing the propane out of the fuel lines (purging) is required before attempting to remove any of the components. Following the suggested techniques for purging will discharge a minimum of the vapor harmlessly into the atmosphere and produce the least risk to life and property.

Make certain to observe the alert messages. They consist of reminders of **Dangers**, **Warnings** and **Cautions**. Other reminders may appear under the heading, **Notes**.

Several components attached to the Multivalve on the fuel tank cannot be removed from the Multivalve until after the fuel tank is removed from the vehicle. This includes the:

- fuel supply line
- fuel return line
- fuel fill line
- fuel pump control solenoid

The electrical harness attached to the tank is a permanent fixture and cannot be removed in the field.

## Purging the Fuel Tank

A propane fuel tank must be empty of propane before it can be transported by a carrier. Due to the volume of fuel likely to be retained in the fuel tank, releasing the vapor to the atmosphere would be wasteful, unsafe and an extremely slow procedure without special equipment. It is suggested that a local, certified propane handling company be engaged to purge the fuel tank and recapture the fuel as the need requires.

## Purging System Fuel Lines

1. Disconnect the 4-pin electrical connector at the frame rail on the driver's side near the fuel tank.

**Note** — This disconnects the power to the fuel pump.

2. Start the engine and let it run until it stalls.

**Note** — This purges the supply and return fuel lines of propane.

3. Turn off the ignition.
4. Disconnect the negative battery cable from the battery.



## Manual Fuel Shutoff

**Note** — This procedure ensures that no propane leaves the fuel tank during service activity.

**▲ Warning** — Care must be taken while working with liquid propane. All steps must be followed to prevent personal injury and component damage.

1. With the engine turned off, remove the negative battery cable from the battery.
2. Remove the spring clamp and pressure relief hose from the 90-degree elbow on the Multivalve cover.

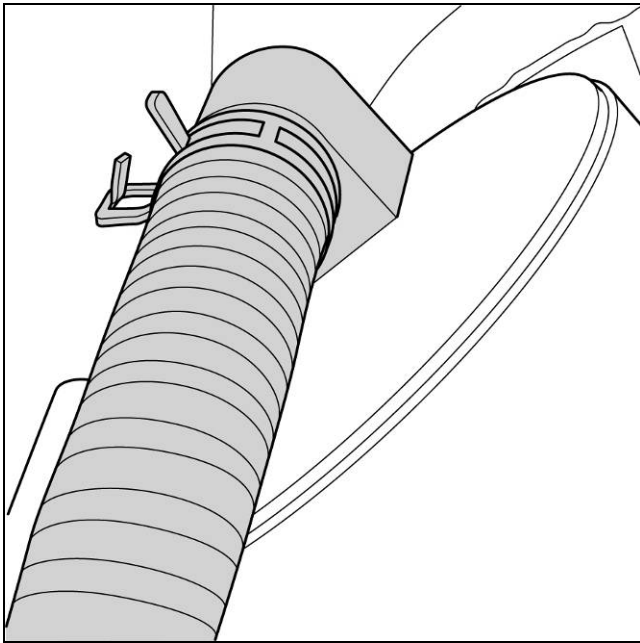

**Figure 25 — Spring Clamp and Pressure Relief Hose**

3. Remove the 90-degree elbow from the pressure relief valve on the Multivalve cover (turn counter-clockwise) and remove the cover.

**Note** — Some applications have a nut under the 90-degree elbow that must be removed prior to removing the cover.

**▲ Caution** — If the 90-degree elbow or nut and tube assembly spins and cannot be removed, STOP and contact ROUSH CleanTech Customer Service at 800-597-6874.

4. With the cover removed, locate the manual shutoff valve. Turn the manual shutoff valve clockwise until it stops. The propane supply from the tank is now shut off.

**Note** — The manual shutoff valve can be hard to turn. From fully open to fully closed is approximately 2-1/2 turns.

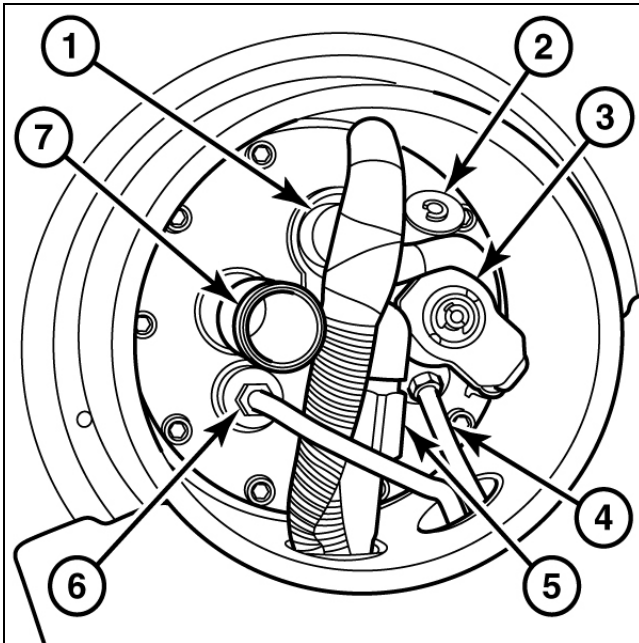

Figure 26 — Multivalve Assembly

1. Electrical Pass Through (not serviceable)	5. Fuel Filler Inlet Elbow
2. Manual Shutoff Valve	6. Fuel Return Line
3. Fuel Supply Solenoid	7. Pressure Relief Valve
4. Fuel Supply Line	

### Opening Manual Shutoff Valve

1. After fuel system service is completed, open the manual shutoff valve on the fuel tank, turning the valve counter-clockwise until it stops. Make sure to open the shutoff valve slowly. Releasing fuel quickly into an empty fuel line can set off a special check valve, which could restrict fuel flow.

**Note** — If difficulty occurs, close the manual shutoff valve completely and then open it again, slowly.

**Note** — The manual shutoff valve can be hard to turn. From fully open to fully closed is approximately 2-1/2 turns.

2. Install the Multivalve cover and attach the 90-degree elbow to the pressure relief valve on the cover. Ensure that the elbow is tight and leads to the driver's side of the vehicle.

**▲ Caution** — Hand tighten the 90-degree elbow to avoid cross threading. Failure to heed this caution can result in component damage.

**Note** — When installing the 90-degree elbow and brass tube to the Multivalve, use anti-seize on the threads prior to assembly.

## ROUSH® CleanTech F-250/F-350 Liquid Propane Injection Service Manual Supplement

3. Install the pressure relief hose to the 90-degree elbow and attach the spring clamp.
4. Install the negative battery cable. Disable the ignition and crank the engine to purge the fuel lines. **DO NOT START** the engine.
5. With Snoop®, or similar product, leak check the injectors, fuel rails and lines. Repair as necessary.
6. Start and run the engine and check for diagnostic trouble codes. Repair as necessary. Any questions, please contact ROUSH CleanTech Customer Service at 800-597-6874.

### Removing Intake Airbox Cover

1. Disconnect the battery.
2. Loosen and then remove the hose clamps from the intake air tube assembly.

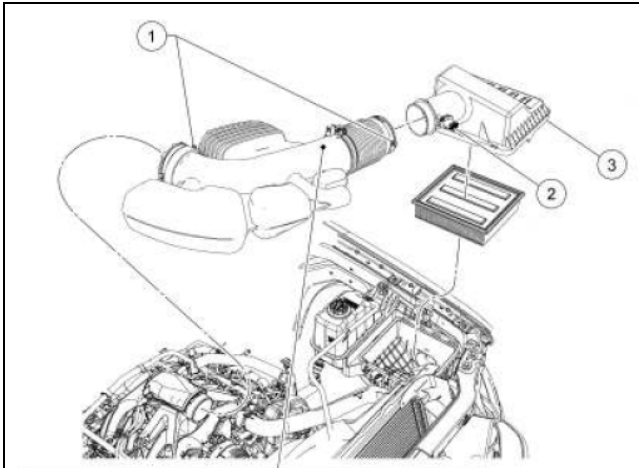

Figure 27 — Intake Air System

1. Hose Clamps	3. Intake Air Box Cover
2. MAF Sensor	

3. Disconnect the Mass Air Flow (MAF) sensor electrical connector.
4. Remove the intake airbox cover.

**Note** — Protect the filter element when setting the cover aside.

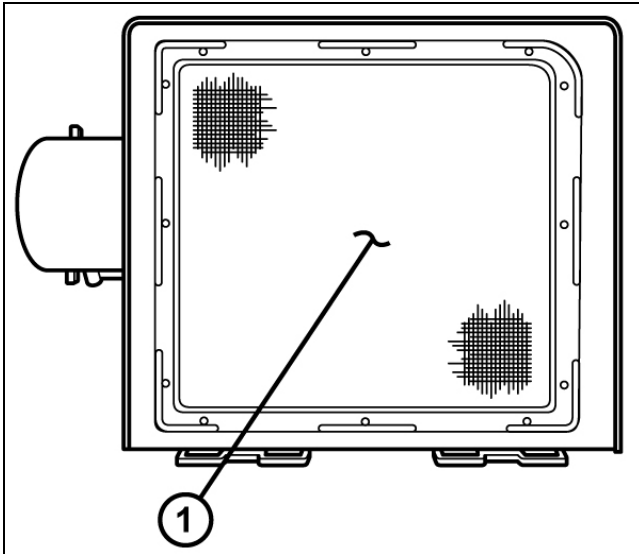

Figure 28 — Intake Airbox Cover with Filter Element (1)

### Installing Intake Airbox Cover

1. Protecting the filter element, assemble the airbox cover onto the airbox.

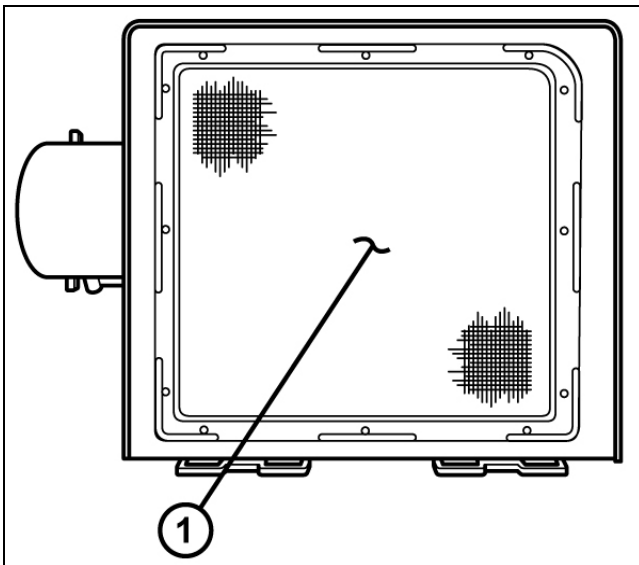

Figure 29 — Intake Airbox Cover with Filter Element (1)

2. Install the hose clamps onto the intake air tube assembly. Position the intake air tube assembly to the air box cover and to the engine.

3. Tighten the intake air tube hose clamps to the specified torque.

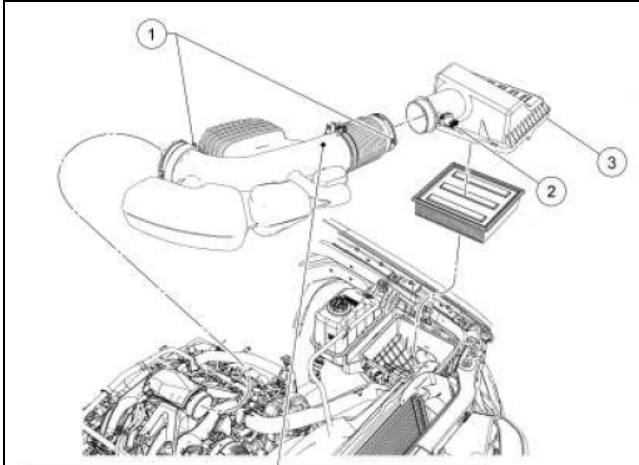

Figure 30 — Intake Air System

1. Hose Clamps	3. Intake Air Box Cover
2. MAF Sensor	

4. Plug in the MAF sensor electrical connector.
5. Connect the battery.

## Fuel System Component Removal Procedures

### Removing Pressure Relief Hose

1. Disconnect the pressure relief hose from the outlet nozzle bracket at the fender support rod.

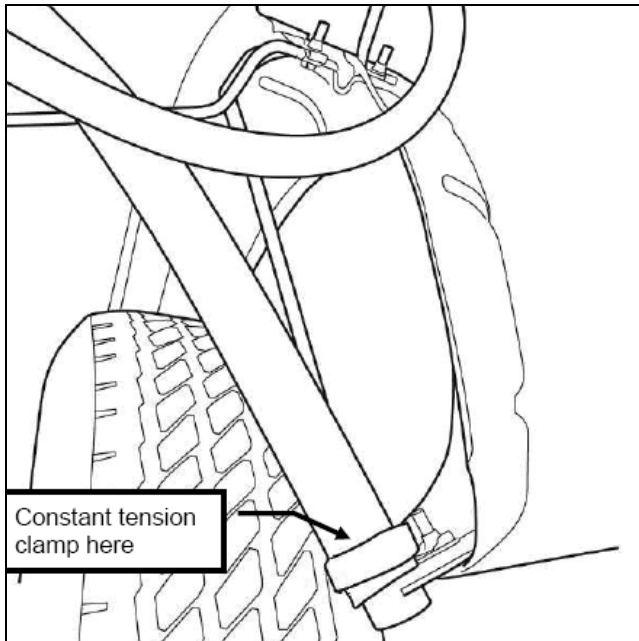

Figure 31 — Pressure Relief Hose Lower Connection

2. Disconnect the pressure relief hose from the 90-degree elbow in the Multivalve cover.

## Removing Flow Control Solenoid

1. Purge the propane from the fuel lines.

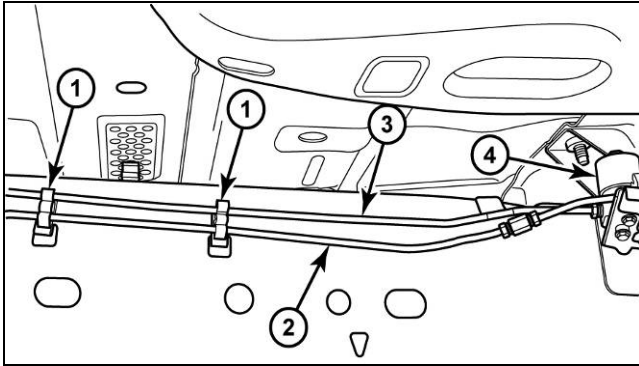

Figure 32 — Flow Control Solenoid and Fuel Lines

1. Retention Clip	3. Intermediate Return Line
2. Intermediate Supply Line	4. Flow Control Solenoid

2. Disconnect the forward fuel return line at the solenoid.
3. Disconnect the intermediate fuel return line at the solenoid.
4. Disconnect the solenoid electrical connector.
5. Remove the solenoid from its mounting bracket.

## Removing Fuel Lines (In-Bed Tank to Solenoid)

**Note** — The fuel supply and fuel return lines between the solenoid and the tank are each in multiple sections. The off-tank sections attached to the Multivalve by quick connect fittings and pass through the tank grommet to terminate below the truck bed. Except for the pressure relief hose, the Multivalve and fuel lines are inaccessible until the tank is removed from the vehicle. All vehicle configurations are similar.

1. Purge the propane from the fuel lines.
2. Close the manual shutoff valve on the tank.
3. Disconnect the intermediate fuel supply line (1) from the forward fuel supply line and from the off-tank fuel supply line.
4. Disconnect the intermediate fuel return line (2) from the flow control solenoid and from the off-tank fuel return line.

5. Remove the fuel lines from the retention clips on the frame rail.

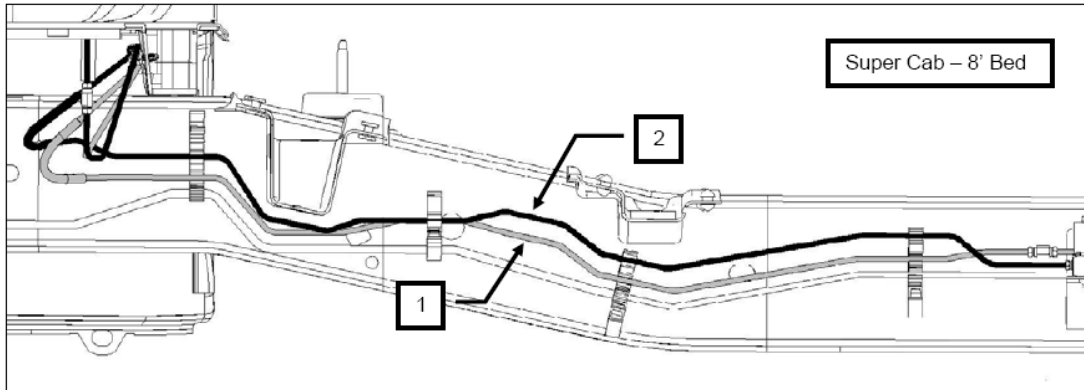

Figure 33 — Intermediate Fuel Line Routing

### Removing Fuel Lines (Under-Vehicle Tank to Solenoid)

**Note** — The fuel supply and fuel return lines quick connected into the fuel tank (Multivalve) are serviceable only with the fuel tank removed.

1. Purge the propane from the fuel lines.
2. Close the manual shutoff valve on the tank.
3. Disconnect the tank fuel supply line from the forward fuel supply line.
4. Disconnect the tank fuel return line from the flow control valve.
5. Disengage the fuel lines from the retention clips on the frame rail.

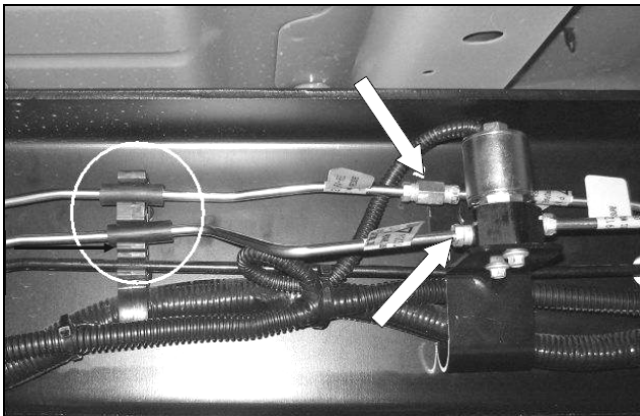
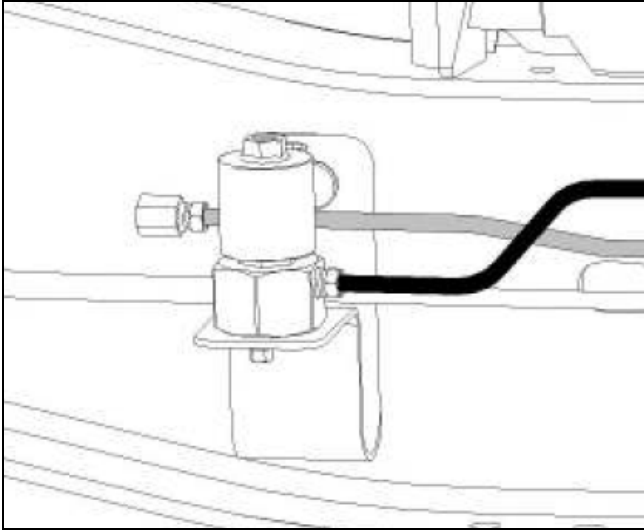

Figure 34 — Tank Fuel Line Connections

### Removing Fuel Lines (Solenoid to Engine)

1. Purge the propane from the fuel lines.
2. Close the manual shutoff valve on the tank.
3. Disconnect the forward fuel supply line from the tank fuel supply line or intermediate fuel supply line (in-bed tank equipped).

4. Disconnect the forward fuel return line from the fuel control solenoid.



**Figure 35 — Forward Fuel Return Line at Flow Control Solenoid**

5. Release the forward fuel supply line from the rear of the right-side fuel rail quick connect fitting.
6. Release the forward fuel return line from the rear of the left-side fuel rail quick connect fitting.
7. Remove the forward lines from the retention clips on the frame rail and from the brackets on the transmission.



**Figure 36 — Forward Fuel Line Connections**



### Removing Fuel Fill Line (Filter to Tank)

**Note** — The fuel fill line cannot be disconnected from the Multivalve before the tank is removed from the vehicle.

**▲ Danger** — A trace amount of propane fuel will be released when loosening the fittings. Propane settles to the lowest available surface before dissipating into the atmosphere. Keep heat, sparks, flames, static electricity or other sources of ignition out of the area when venting or purging the fuel lines or tank. Failure to heed this danger can result in severe personal injury or property damage.

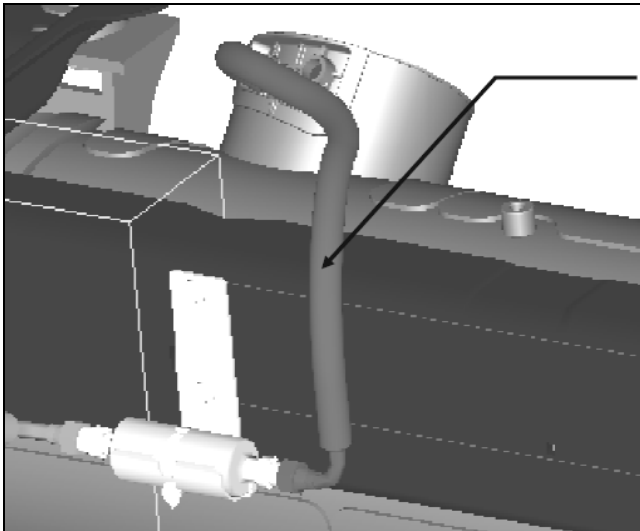

**Figure 37 — Fuel Fill Line (Filter to Tank)**

1. Close the manual shutoff valve on the tank.
2. Disconnect the fuel fill line at the fuel filter.
3. Arrange the line so that it can pass easily through the truck bed if removing an in-bed fuel tank or can pass over the frame rail on under-vehicle fuel tank.
4. Remove the fuel tank to gain access to the fuel fill line on the tank.
5. Disconnect the fuel fill line.

## Removing Fuel Filler Neck

**▲ Danger** — A trace amount of propane fuel will be released when loosening the fittings. Propane settles to the lowest available surface before it dissipates into the atmosphere. Keep heat, sparks, flames, static electricity or other sources of ignition out of the area when venting or purging the fuel lines or tank. Failure to heed this danger can result in severe personal injury or property damage.

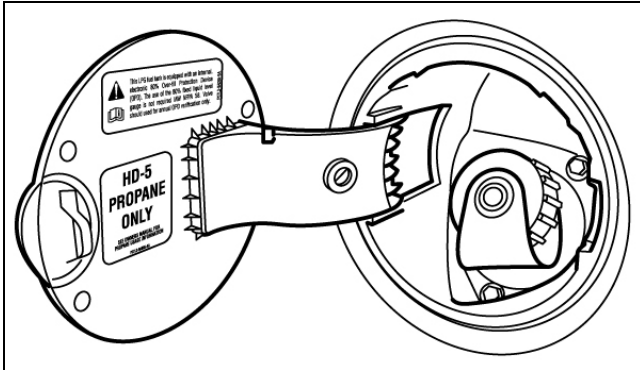

Figure 38 — Fuel Filler Door and Valve with Cap

1. Disconnect the fuel fill line at the fuel filler neck.
2. Remove the bolts holding the fill valve and the fuel filler neck to the vehicle side panel.
3. Remove the bolts attaching the fuel filler neck inside the fuel filler door.
4. Remove the fuel filler neck.

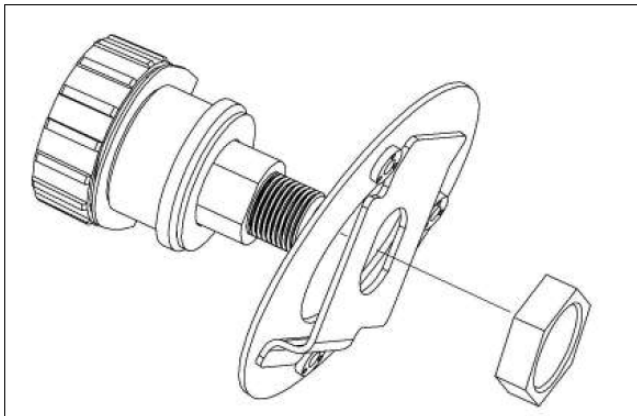

Figure 39 — Fill Valve and Fuel Filler Neck Mounting Bracket

5. Remove the fill valve-to-mounting bracket nut and separate the valve from the bracket.

## Removing Fuel Filter Assembly

**▲ Danger** — A trace amount of propane fuel will be released when loosening the fittings. Propane settles to the lowest available surface before it dissipates into the atmosphere. Keep heat, sparks, flames, static electricity or other sources of ignition out of the area when venting or purging the fuel lines or tank. Failure to heed this danger can result in severe personal injury or property damage.

1. Disconnect the fuel fill line at the filter inlet.

2. Disconnect the fuel fill line at the fuel filter outlet fitting.

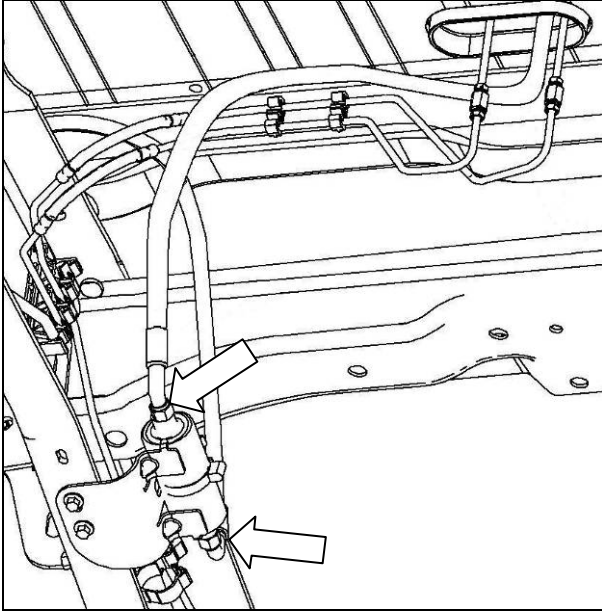

**Figure 40 — Fuel Filter Assembly**

3. Loosen the fuel filter clamp.
4. Remove the fuel filter.

#### **Removing Fuel Fill Line (Neck to Filter)**

**▲ Danger** — A trace amount of propane fuel will be released when loosening the fittings. Propane settles to the lowest available surface before it dissipates into the atmosphere. Keep heat, sparks, flames, static electricity or other sources of ignition out of the area when venting or purging the fuel lines or tank. Failure to heed this danger can result in severe personal injury or property damage.

1. Disconnect the fuel fill line from the inlet end of the fuel filter.
2. Disconnect the fuel fill line from the filler neck.
3. Remove the fuel fill line.

#### **Removing Left (Driver's Side) Fuel Rail**

1. Purge the propane from the fuel lines.
2. Disconnect the Mass Air Flow sensor electrical connector.
3. Remove the throttle body inlet hose.
4. Disconnect the heated PCV hose from the intake manifold.

5. Disconnect the Injection Pressure and Temperature Sensor (IPTS) electrical connector.

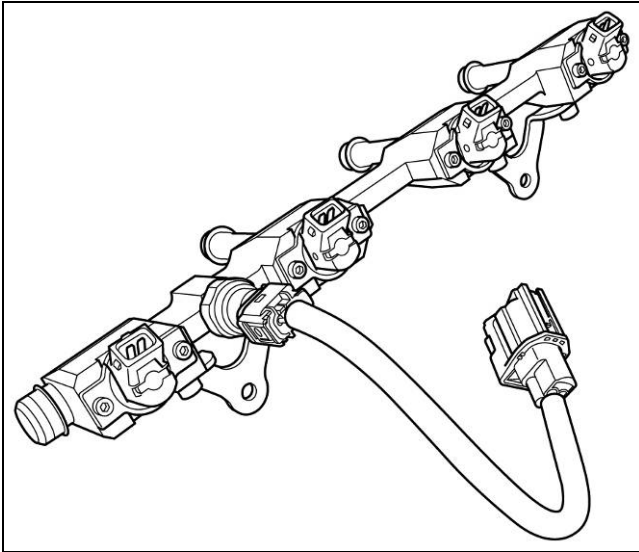

Figure 41 — Injection Pressure and Temperature Sensor and Fuel Rail

6. Disconnect the fuel injector electrical connectors.
7. Disconnect the fuel crossover fuel line.
8. Disconnect the fuel return line at the rear end of the fuel rail.
9. Remove the fuel rail with injectors.

### Removing Right (Passenger's Side) Fuel Rail

1. Purge the propane from the fuel lines.

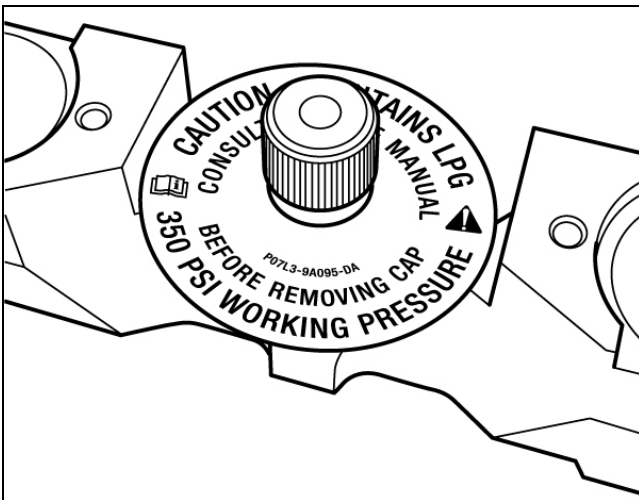

Figure 42 — Fuel Rail with Schrader Valve

2. Disconnect the PCV hose from the throttle body elbow.
3. Disconnect the fuel injector electrical connectors.
4. Disconnect the fuel supply line at the rear end of the right-side fuel rail.

5. Disconnect the crossover fuel line from the right-side fuel rail.

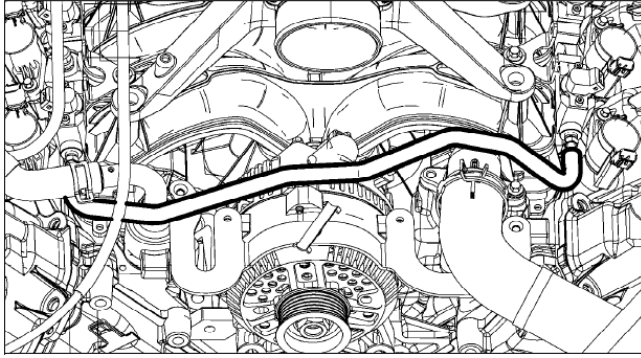

Figure 43 — Crossover Fuel Line

6. Remove the fuel rail with injectors.

### Removing Fuel Injector

1. If not already done, locate the fuel rail service port on the right-side fuel rail. Release the pressure in the fuel rail and lines, venting the pressure into a flare stack.

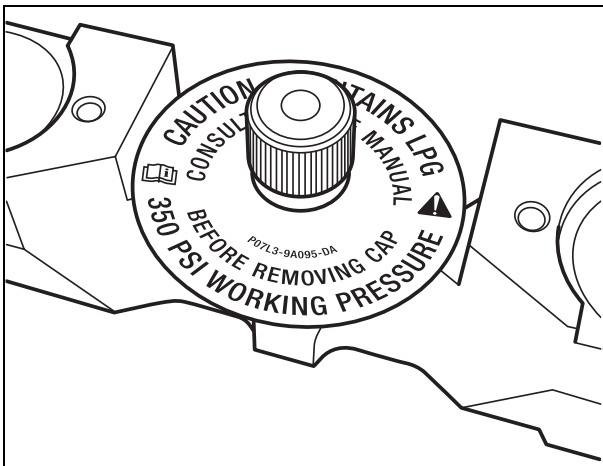

Figure 44 — Fuel Rail Service Port

**▲ Caution** — The fuel rail is under high pressure. Care should be taken when releasing pressure to avoid personal injury.

2. Disconnect the fuel injector connector, remove the fuel injector hold down bracket bolts and remove the bracket.
3. Using a twisting motion, pull the fuel injector out of the fuel rail (a pair of pliers might be necessary to help remove the fuel injector). Use care to prevent damage to the fuel injector. As the fuel injector is being removed from the rail, make sure that the brass calibrator is still down inside the fuel rail and not on the fuel injector.

**Note** — The brass calibrator is assembled with the nozzle and screwed into the bottom of the fuel rail. Replacing the fuel injector does not require removal of the calibrator and nozzle, but in some instances the calibrator can come out of the fuel rail when the fuel injector is removed.

4. Repeat Steps 2–3 as needed for the remaining fuel injectors.

## Removing Injection Pressure and Temperature Sensor

1. Purge the propane from the fuel lines.

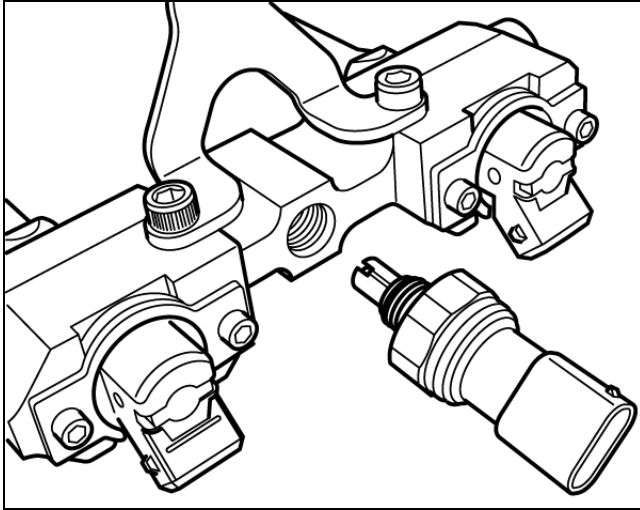

Figure 45 — Injection Pressure and Temperature Sensor

2. Disconnect the electrical connector from the Injection Pressure and Temperature Sensor (IPTS).
3. Remove the IPTS from the left-side fuel rail.

## Fuel Tank Removal Procedures

### Purging Fuel Tank

A propane fuel tank must be empty of propane before it can be transported by a carrier. Due to the volume of fuel likely to be retained in a tank, releasing the vapor to the atmosphere would be wasteful, unsafe and an extremely slow procedure without special handling equipment. It is suggested that a certified propane handling company be engaged to purge the fuel tank as needed.

### Removing In-Bed Tank

**Note** — Before removing the in-bed tank from the vehicle, provide a suitable place to put it where it can be worked on after removal from the vehicle. The tank may also require temporary storage awaiting preparation for shipment.

1. Purge the propane from the fuel lines.
2. Disconnect the fuel fill line at the inlet of the fuel filter.

3. Disconnect the off-tank fuel lines from the intermediate fuel supply and fuel return lines.

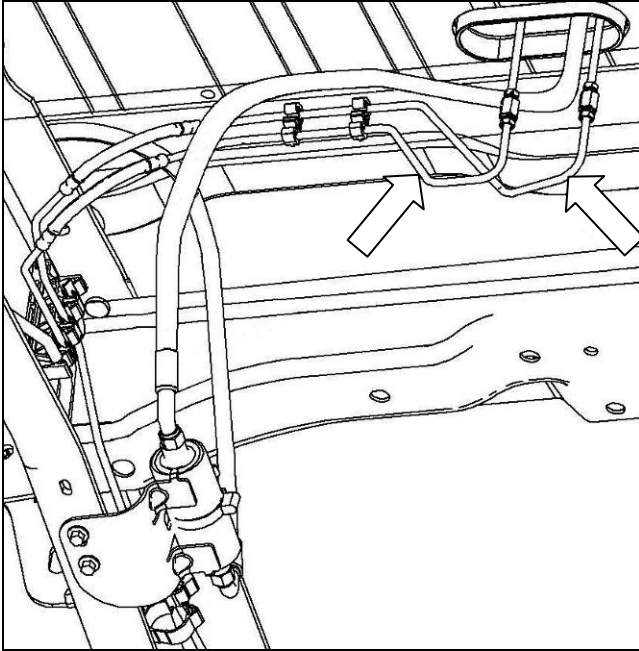

Figure 46 — Fuel Lines

4. Detach the off-tank fuel lines from the retention clips.
5. Disconnect the pressure relief hose from the outlet nozzle at the fender support rod.

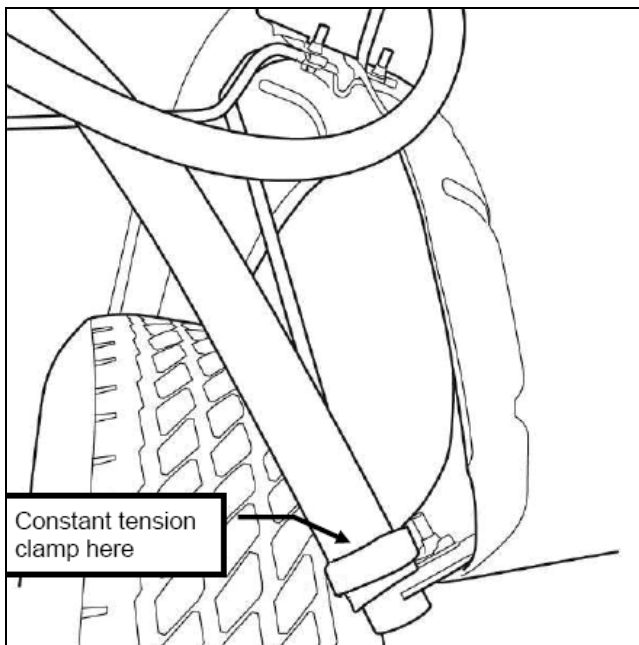
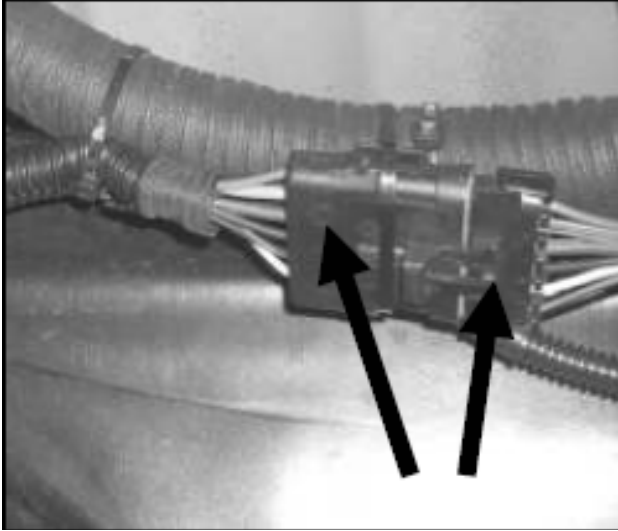

Figure 47 — Pressure Relief Hose Lower Connection

6. Disconnect the fuel tank electrical connector.



**Figure 48 — Fuel Tank Electrical Connector**

7. Remove the nuts, steel washers and rubber isolators attaching the tank.
8. Obtain a 5/8-11 threaded lifting eye and a hoist capable of safely lifting 1000 pounds.
9. Using an Allen wrench, remove the protective insert from the tapped weldment on top of the tank.
10. Install the lifting eye in the weldment.
11. With the help of an assistant, attach the hoist, remove the tank from the truck bed and place it on a suitable surface.

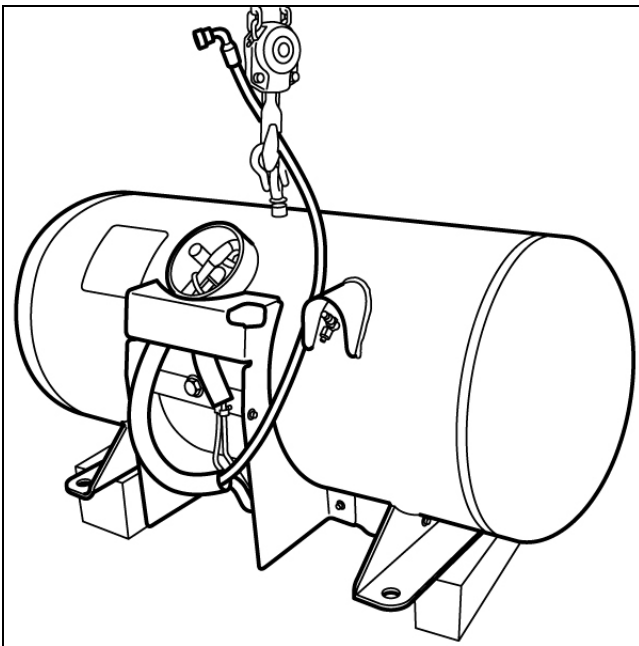

**Figure 49 — In-Bed Tank on Blocks**

**Note** — Make a note of the holes in the truck bed through which the fuel and electrical lines pass in order to direct the lines on installation.



**▲ Caution** — Fuel lines remain attached to the Multivalve and extend below the tank support weldments. Ensure that clearance is provided when resting the tank on any surface. Failure to heed this caution can result in component damage.

12. Detach the hoist and remove the lifting eye.
13. Install the protective insert in the weldment.
14. Remove the shield from the tank.

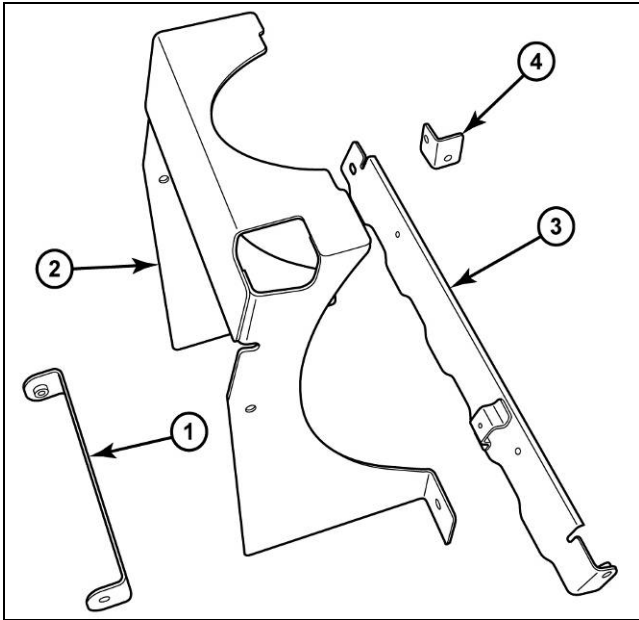

**Figure 50 — In-Bed Fuel Tank Shield Components**

1. Upper Cross Brace	4. Lower Cross Brace L Bracket (2 required)
2. Fuel Line Shield	
3. Lower Cross Brace	

15. Remove the convolute tubing from the fuel lines.
16. Remove the convolute tubing from the fuel fill line and the electrical cables.
17. Disconnect the fuel supply line at the Multivalve quick connect supply port.
18. Disconnect the fuel return line at the Multivalve quick connect return port.
19. Remove the fuel fill line.
20. Remove the fuel supply solenoid.

**▲ Caution** — Make sure the manual shutoff valve is turned off.

### Removing Under-Vehicle Tank

**Note** — Provide a suitable place to put the fuel tank so that it can be worked on after removing the tank from the vehicle. The tank may also require temporary storage in preparation for shipment.

## ROUSH® CleanTech F-250/F-350 Liquid Propane Injection Service Manual Supplement

---

**Note** — Close the manual shutoff valve to ensure that no propane leaves the fuel tank during service activity.

**⚠ Warning** — Care must be taken while working with liquid propane. All steps must be followed to prevent personal injury and component damage.

1. Purge the propane from the fuel lines.
2. With the engine turned off, remove the negative battery cable from the battery.
3. Remove the spring clamp and pressure relief hose from the 90-degree elbow on the Multivalve cover. Secure the pressure relief hose out of the way.

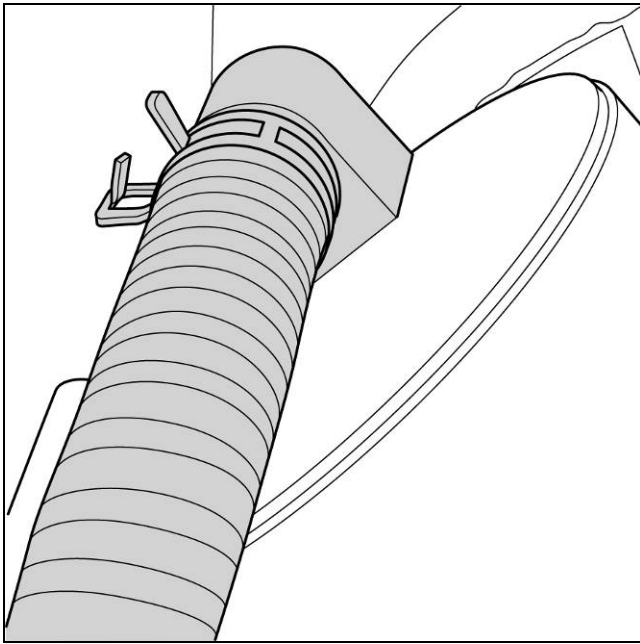

**Figure 51 — Spring Clamp and Pressure Relief Hose**

4. Remove the 90-degree elbow from the pressure relief valve on the Multivalve cover (turn counter-clockwise) and remove the cover.

**Note** — Some applications have a nut under the 90-degree elbow that must be removed prior to removing the cover.

**⚠ Caution** — If the 90-degree elbow or nut and tube assembly spins and cannot be removed, STOP and contact ROUSH CleanTech Customer Service at 800-597-6874.

**ROUSH® CleanTech F-250/F-350 Liquid Propane Injection  
Service Manual Supplement**

---

5. With the cover removed, locate the manual shutoff valve. Turn the manual shutoff valve clockwise until it stops. The propane supply from the tank is now shut off.

**Note** — The manual shutoff valve can be hard to turn. From fully open to fully closed is approximately 2-1/2 turns.

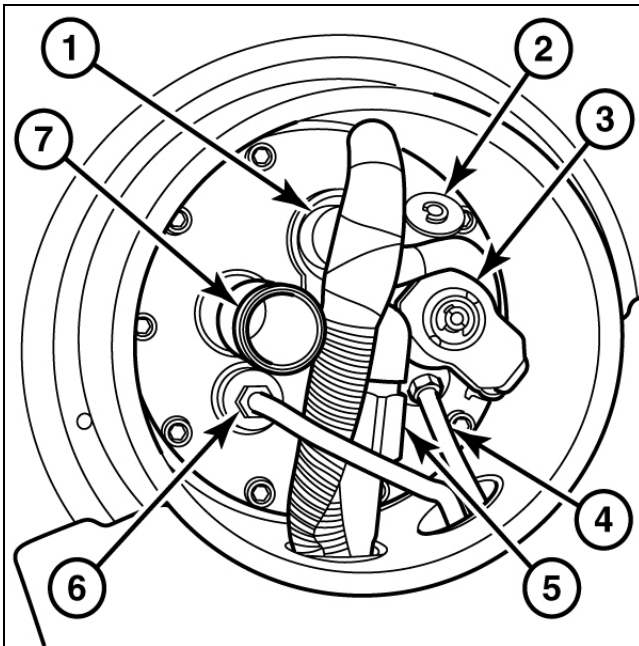

**Figure 52 — Multivalve Assembly**

1. Electrical Pass Through (not serviceable)	5. Fuel Filler Inlet Elbow
2. Manual Shutoff Valve	6. Fuel Return Line
3. Fuel Supply Solenoid	7. Pressure Relief Valve
4. Fuel Supply Line	

6. Disconnect the fuel tank-to-filter fuel fill line at the outlet of the fuel filter.

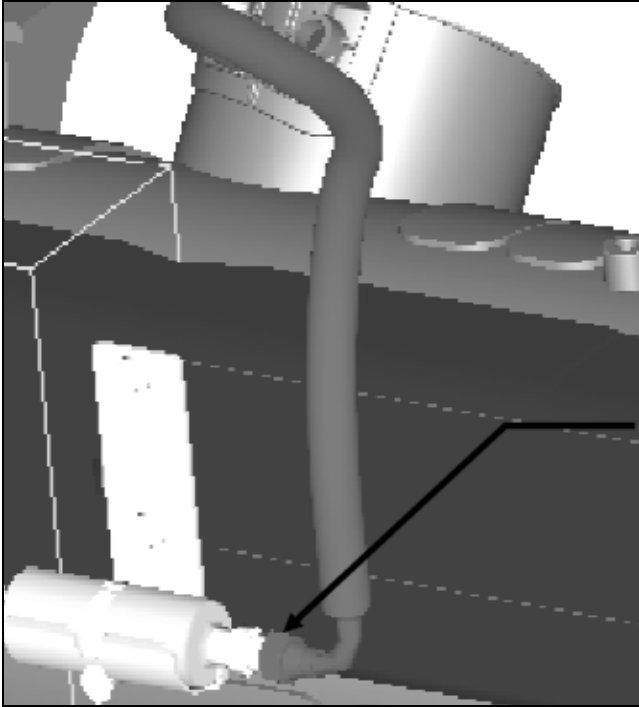

Figure 53 — Fuel Fill Line at Filter Outlet

7. Disconnect the fuel tank fuel supply line from the forward fuel supply line and the fuel tank fuel return line from the fuel control solenoid.

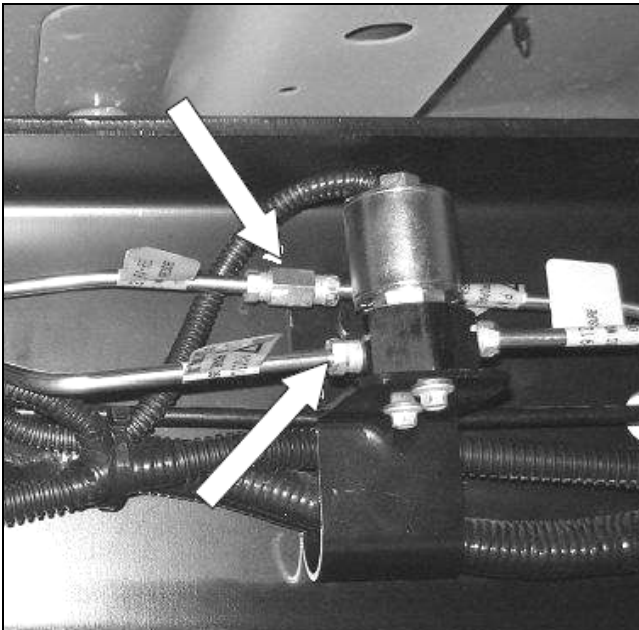

Figure 54 — Fuel Tank Fuel Supply and Fuel Return Line Connections

8. Detach the fuel lines from the retaining clips.

- Cut the tie straps and then disconnect the fuel tank 6-pin connector.

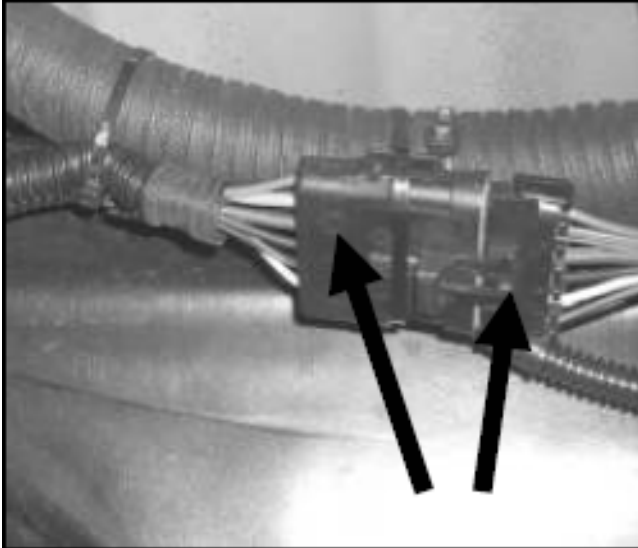

Figure 55 — Fuel Tank Electrical Connector

- Crew Cab and Super Cab Vehicles ONLY:** The midship bearing and bracket must be removed and set aside in order to access the fuel tank fasteners at the front crossmember.
  - Support the driveshaft assembly. Remove the four bolts (two hidden from view) securing the midship bearing bracket to the ROUSH midship mounting bracket attached to the front crossmember.
  - Move the driveshaft, midship bearing and bearing bracket out of the way toward the passenger side of the vehicle. Support the drive shaft with a suitable lifting strap.
- ▲ Caution** — To avoid damage or contamination, do NOT allow the slip joint to come apart from the driveshaft. Move the assembly only far enough to gain clearance for tank removal.

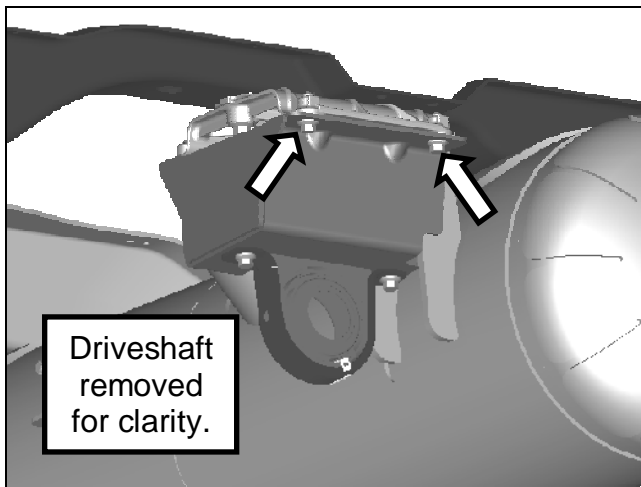

Figure 56 — Driveshaft, Midship Bearing and Bearing Bracket

- Obtain a hoist capable of safely lifting 1000 pounds. Attach the hoist to the fuel tank using lifting straps. Support the tank while removing the tank mounting fasteners.

14. Remove the two bolts and steel washers attaching the outboard tank mounts to the frame rail. Remove the mounting isolators and crush limiters as necessary.

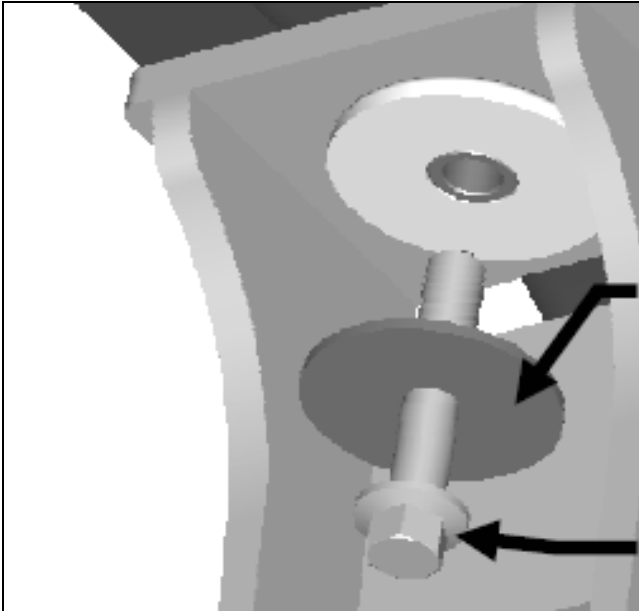

Figure 57 — Outboard Fuel Tank Mounting Bolt and Washer

15. **Rear Crossmember Mount:** Remove the nut and steel washer attaching the inboard rear tank mount to the rear crossmember. Remove the mounting isolator and crush limiter as necessary.

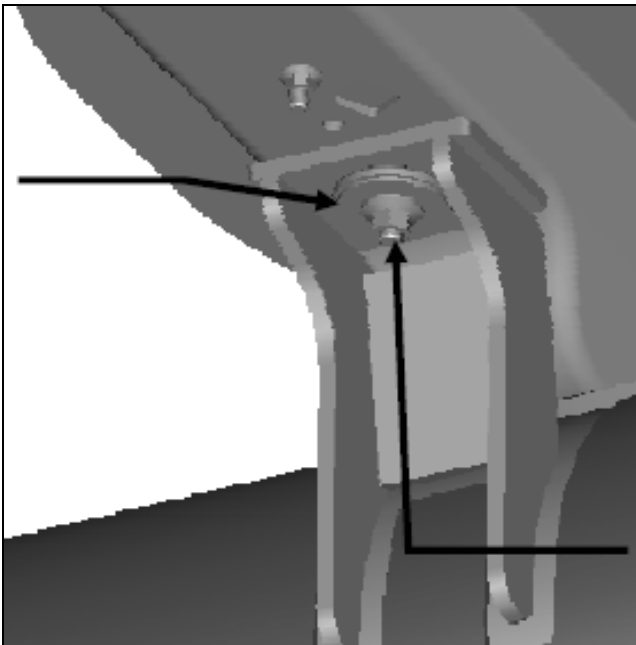
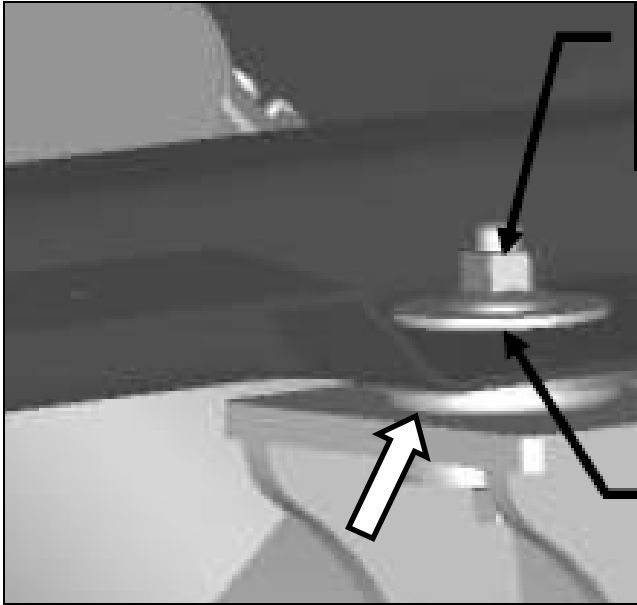

Figure 58 — Inboard Fuel Tank Mounting Bolt and Washer

16. **Front Crossmember Mount:** Remove the bolt, two steel washers, nut, isolator and spacer (when equipped) attaching the inboard front tank mount to the front crossmember. Remove the lower mounting isolator and the crush limiter as necessary.

**Note** — In regular and crew cab models ONLY: Remove the front crossmember spacer.



**Figure 59 — Fuel Tank Mounting Fasteners at Front Crossmember**

17. **Crew Cab and Super Cab Vehicles ONLY:** The spacer is not required due to the crossmember midship mount bracket.

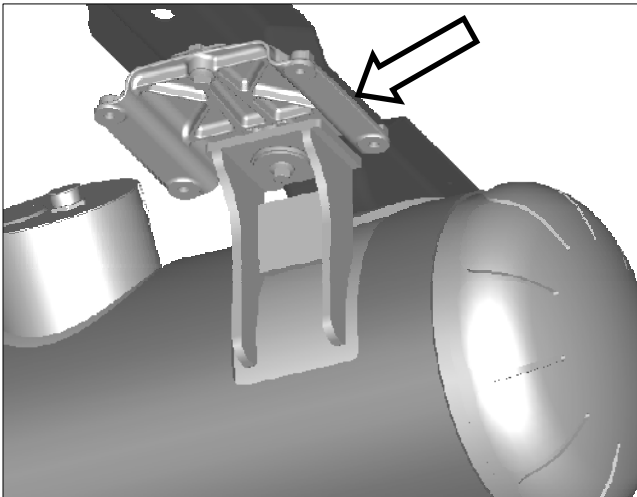

**Figure 60 — Crew Cab and Super Cab Fuel Tank Mounting Fasteners at Front Crossmember**

18. With help from an assistant, lower the tank from under the vehicle and place it on a suitable surface.

**▲ Caution** — Fuel lines remain attached to the Multivalve and can extend below the tank support weldments. Ensure that clearance is provided when resting the tank on any surface. Failure to heed this caution can result in component damage.

19. Detach the hoist and remove the lifting straps.

20. Remove the convolute tubing from the fuel lines.

21. Remove the convolute tubing from the fuel fill line and the electrical cables.

**ROUSH® CleanTech F-250/F-350 Liquid Propane Injection  
Service Manual Supplement**

22. Disconnect the fuel supply line and the fuel return line from the Multivalve quick connect supply and return ports.

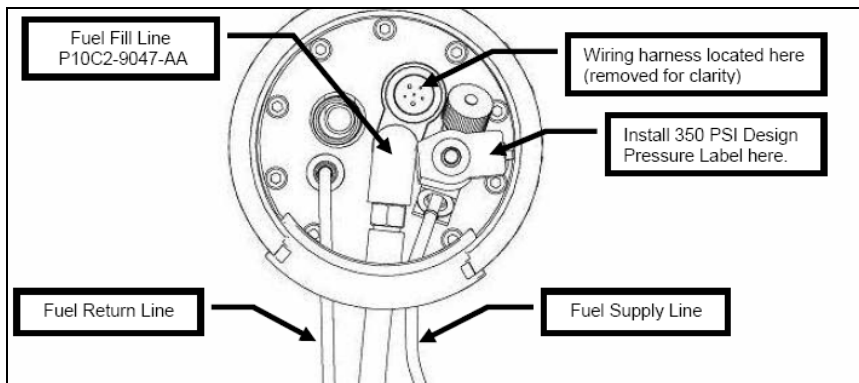

**Figure 61 — Multivalve Connections**

23. Disconnect the fuel supply and fuel return lines from the retention clip on the tank strap bracket.

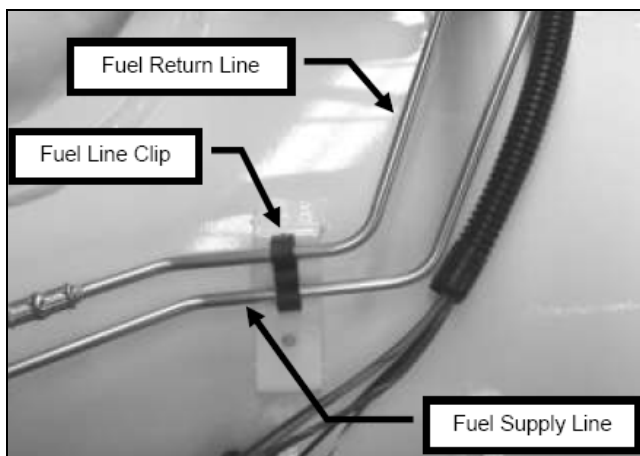

**Figure 62 — Fuel Lines and Retention Clip (Typical)**

24. Pull the fuel lines out of the tank collar grommet.  
25. Remove the E-clip and pull off the fuel supply solenoid.



26. Remove the fuel fill line from the 90-degree fitting on the Multivalve.

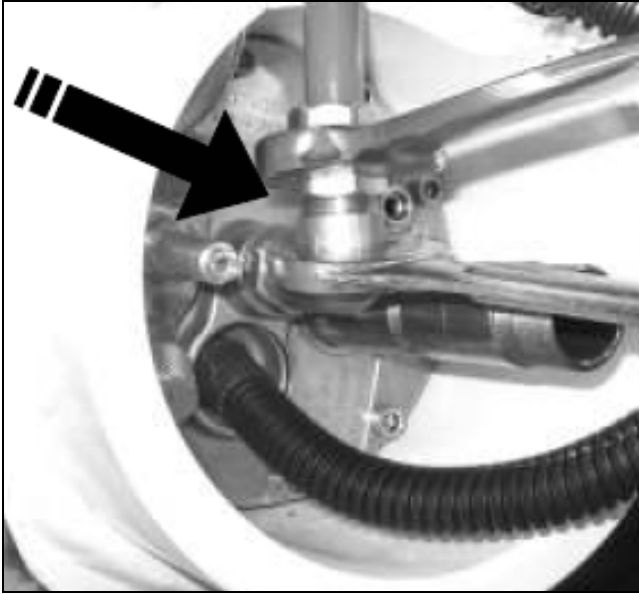

Figure 63 — Fuel Fill Line

27. Pull the fuel fill line through the tank collar grommet.

28. Remove the fuel tank collar grommet and carefully slide it off of the wiring harness.

## Fuel Tank Installation Procedures

### LPG System Bleed and Fill Procedure

The following procedure is required in order to ensure that the fuel system is leak-free and that any residual nitrogen is removed from the system. Failure to complete this process could result in leaks, excessive tank pressure and filling problems.

1. Bleed tank from the bleeder valve to ensure no air is present in the system. Close the bleeder valve.
2. Fill the tank with 0.1 (1/10) gallon of propane and cycle the ignition key to the crank position and then to the off position. **(Do not allow the vehicle to start during this step.)**
3. Inspect and monitor for any leaks.
4. Remove the bleeder valve cap and open the bleeder valve for 10 minutes or until propane stops bleeding, whichever comes first. Close the bleeder valve and install the bleeder valve cap.
5. Fill the tank with five gallons of propane.

**Note — The next step confirms if any leaks are present in the fuel system.**

6. Perform a final leak inspection at all fuel fill and fuel line connections to ensure no leaks are present using Snoop®, or a dish soap and water mixture.
7. Perform End Of Line (EOL) testing and road test.
8. Verify that there are no concerns and fill the vehicle and record the total amount of gallons to fill the vehicle.

## Installing Under-Vehicle Tank

**▲ Caution** — Hand tighten all fuel line connections and fasteners before using a wrench to avoid cross threading. Failure to heed this caution can result in component damage.

1. Insert the tank end of the fuel supply line (2) and the fuel return line (1) through the tank collar grommet (3).
2. Install the tank collar grommet onto the tank collar.
3. Carefully install the wiring harness through the upper right hole of the tank collar grommet.

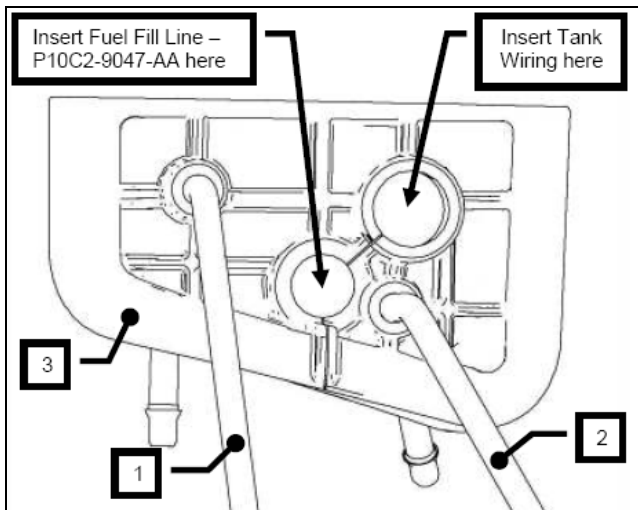

Figure 64 — Fuel Lines and Tank Collar Grommet

4. Install the fuel fill line through the lower center hole in the tank collar grommet.
5. Assemble the fuel fill line to the 90-degree fitting on the Multivalve. Support the fitting while tightening the fill line to the specified torque.

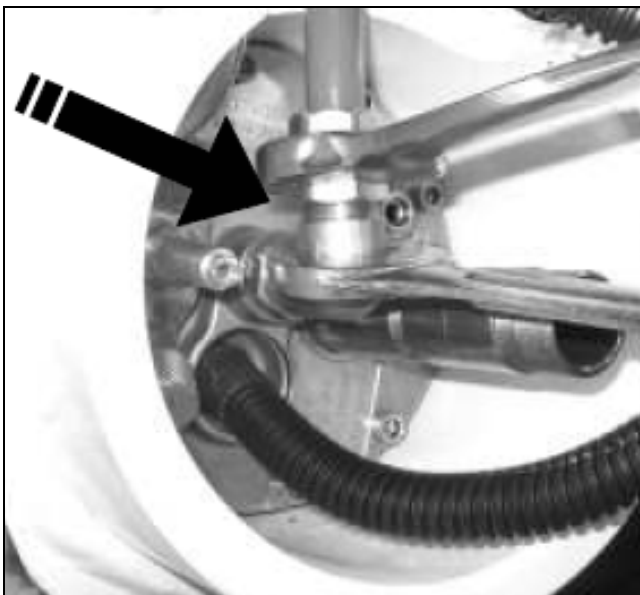
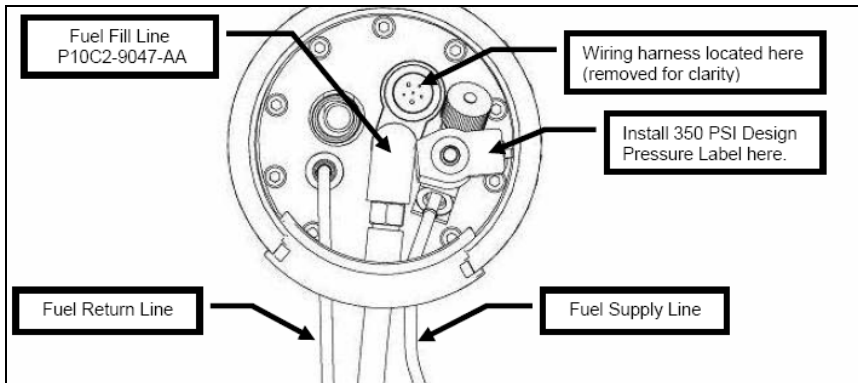

Figure 65 — Fuel Fill Line

6. Position the fuel supply solenoid and install the E-clip.

**ROUSH® CleanTech F-250/F-350 Liquid Propane Injection  
Service Manual Supplement**

7. Connect the fuel supply line and the fuel return line to the Multivalve quick connect supply and return ports. Give each line a firm pull to make sure that the quick connect fittings have locked into position.



**Figure 66 — Multivalve Connections**

8. Connect the fuel supply and fuel return lines to the retention clip on the tank strap bracket.

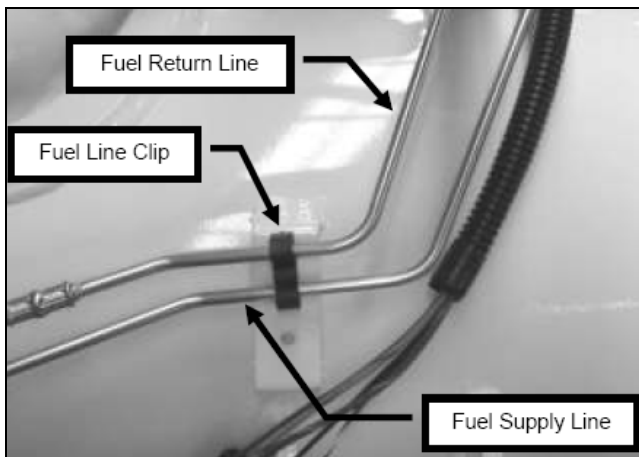

**Figure 67 — Fuel Lines and Retention Clip (Typical)**

9. Install the convolute tubing onto the fuel fill line and the electrical cables.

10. Install the convolute tubing over the fuel supply and return lines.



**Figure 68 — Fuel Lines, Wiring and Convolute Tubing**

11. Arrange the fuel lines and wiring harness as shown so that the Multivalve cover can be easily installed later.

**Note** — There is a connector with two wires for engineering diagnostics at this time.

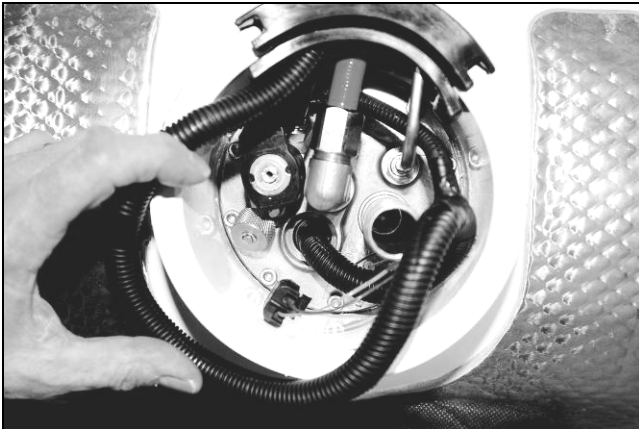

**Figure 69 — Fuel Line and Wiring Arrangement**

12. If removed, secure one rubber isolator to the top side of each of the four tank mounting brackets. Use a high-strength fast-curing adhesive to keep the isolators in place.

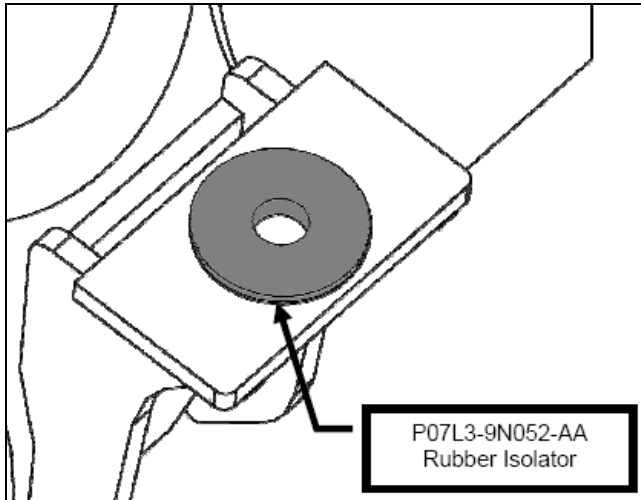

**Figure 70 — Upper Isolator**

13. Attach the hoist and the lifting straps to the fuel tank.
14. Position the fuel tank under the vehicle.
15. Tuck the fuel lines, fuel fill line and wiring harness up against the fuel tank.
16. Slowly raise the fuel tank into position. Make sure to align the mounting holes of the tank with the four mounting bracket holes.
17. With the tank brackets aligned and fully seated on the frame and cross members, install the four crush limiters and tank mounting isolators.

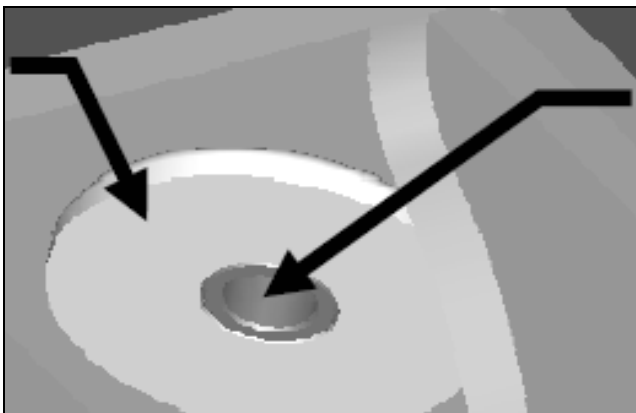

**Figure 71 — Lower Isolator and Crush Limiter**

18. **Outboard Frame Mounts:** Loosely install the steel washers and two outboard tank mounting bolts into the frame mounts. Do not tighten until all tank mounting fasteners are aligned and installed.

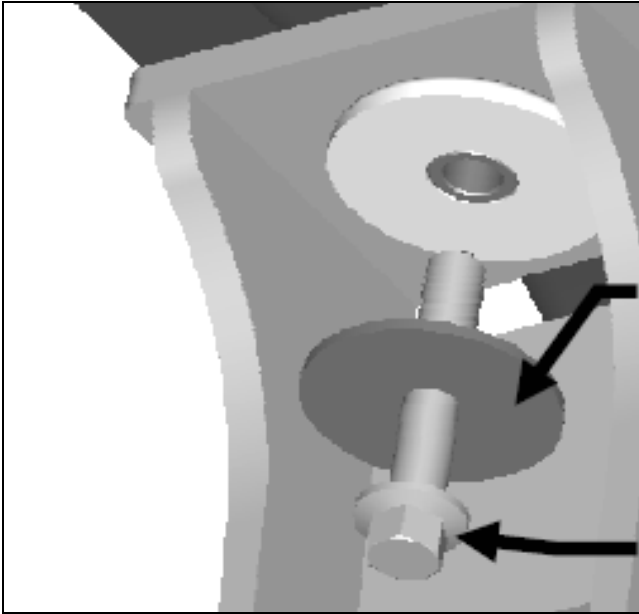

Figure 72 — Outboard Fuel Tank Mounting Bolt and Washer

19. **Rear Crossmember Mount:** Loosely install the steel washer and nut onto the rear crossmember bracket stud.

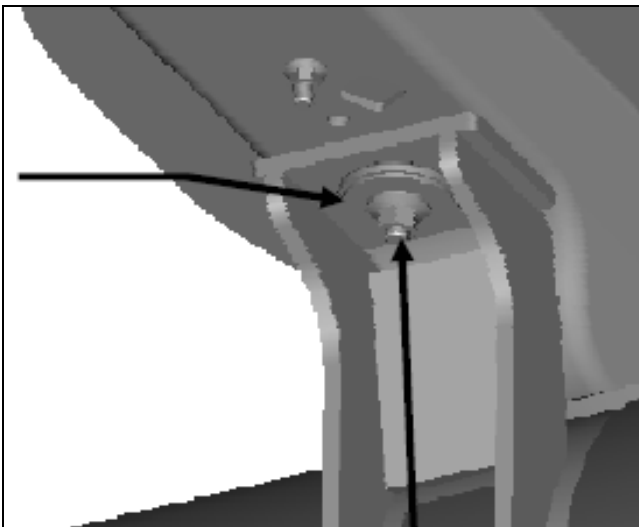
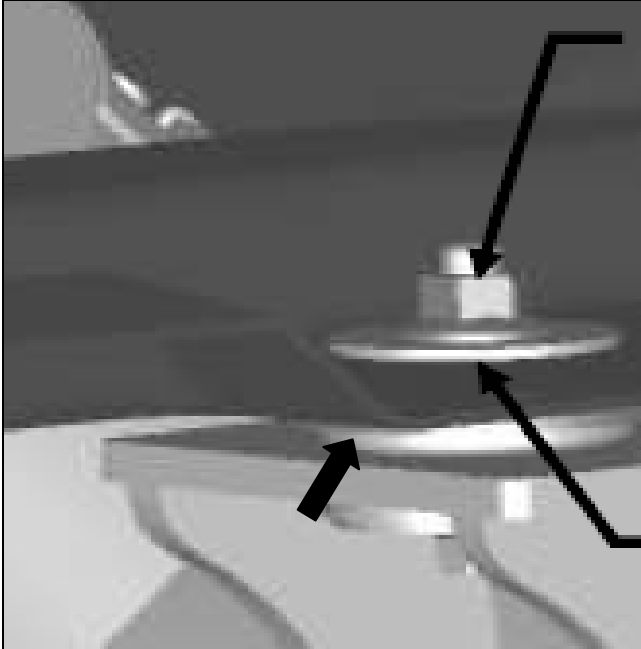

Figure 73 — Inboard Fuel Tank Mounting Nut and Washer at Rear Crossmember

20. **Front Crossmember Mount:** Position a steel washer on top of the crossmember. Install the bolt with steel washer through the tank mounting bracket from the bottom and through the crush limiter and top washer. Hand tighten the bolt into the nut.

**Note** — Regular and Crew Cab Vehicles ONLY: Install the mounting spacer between the tank upper isolator and front crossmember.



**Figure 74 — Inboard Fuel Tank Mounting Bolt, Two Washers and Nut at Front Crossmember**

**Crew Cab and Super Cap Vehicles Only:** When installing the fuel tank into a Crew Cab or Super Cab vehicle, no spacer is required at the front crossmember. The midship mount bracket serves this purpose.

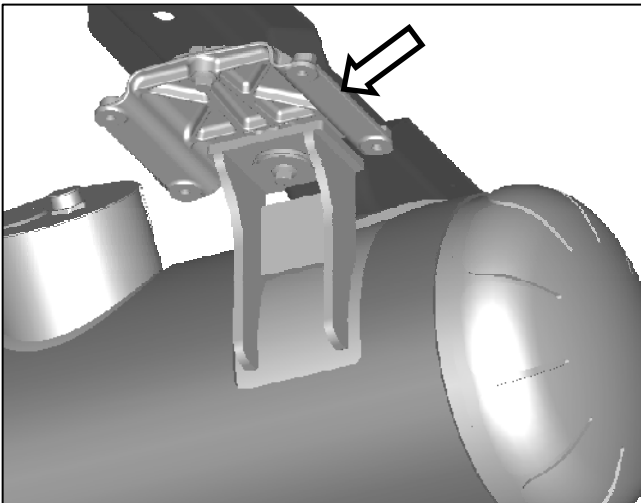

**Figure 75 — Crew Cab/Super Cab Front Crossmember Mounting**

21. With all fuel tank mounting fasteners installed, tighten all mounting fasteners to the specified torque.
22. Remove the hoist and lifting straps.

23. **Crew Cab and Super Cab Vehicles ONLY:** Support the driveshaft assembly using a suitable lift. Untie the driveshaft from the stored location. Position the driveshaft assembly with midship bearing and midship bearing support bracket to the ROUSH midship mount bracket. Install the four bolts (two hidden from view) to secure the assembly. Tighten the four bolts to the recommended torque.

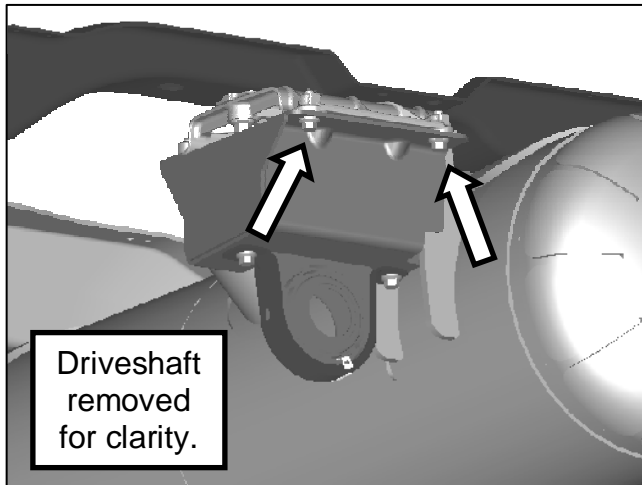

Figure 76 — Crew Cab/Super Cab Driveshaft Installation

24. Connect the fuel tank 6-pin connector to the main body harness connector. Install tie straps as necessary to secure the harness.

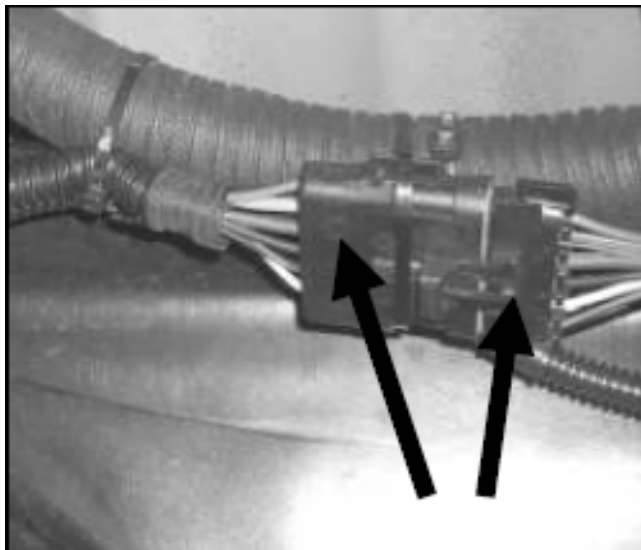
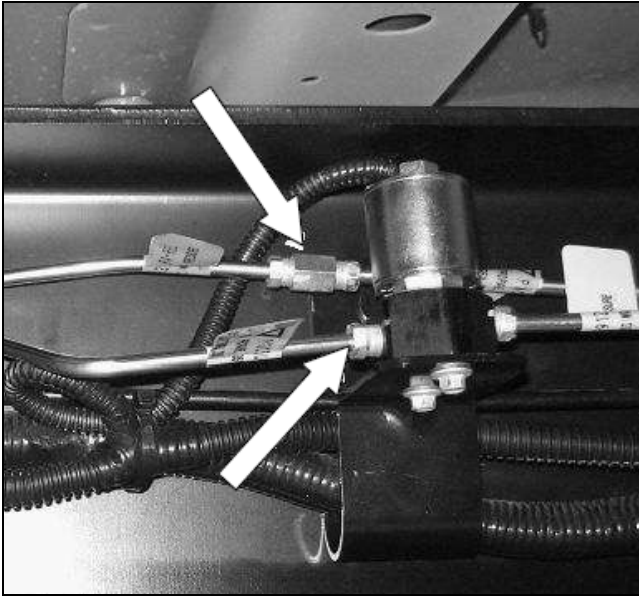

Figure 77 — Fuel Tank Electrical Connector

25. Connect the fuel supply line to the forward fuel supply line and the fuel return line to the fuel control solenoid. Tighten the fuel line fittings to the specified torque.



**Note** — Make sure the fuel lines are not twisted at the flex line locations during the tightening procedure.



**Figure 78 — Fuel Line Connections at Forward Fuel Line and Fuel Control Solenoid**

26. Attach the fuel lines to the retaining clips along the frame.
27. Route the fuel fill line toward the outlet of the fuel filter.
28. Connect the fuel tank-to-filter fuel fill line to the outlet of the fuel filter. Tighten the fitting to the specified torque.

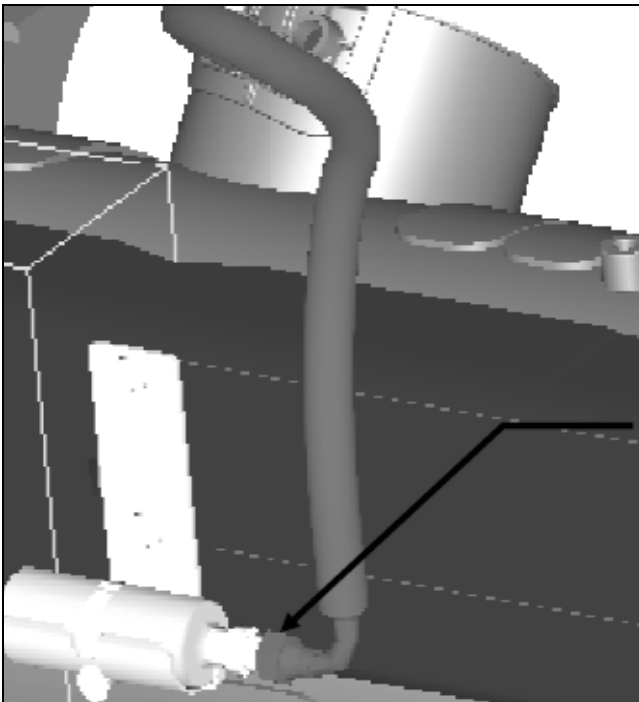

**Figure 79 — Fuel Fill Line at Filter Outlet**

29. Turn the manual shutoff valve counterclockwise until it stops. This opens the fuel supply to the system.

ROUSH® CleanTech F-250/F-350 Liquid Propane Injection  
Service Manual Supplement

**Note** — The manual shutoff valve can be hard to turn. From fully open to fully closed is approximately 2-1/2 turns.

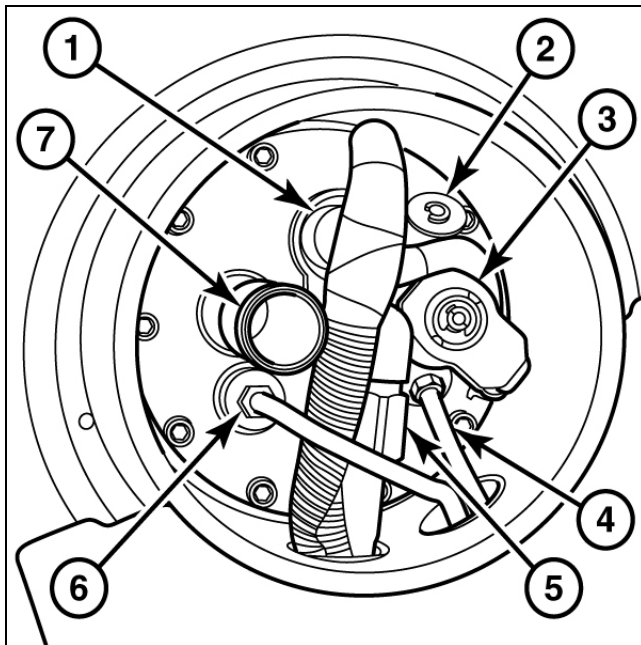

Figure 80 — Multivalve Assembly

1. Electrical Pass Through (not serviceable)	5. Fuel Filler Inlet Elbow
2. Manual Shutoff Valve	6. Fuel Return Line
3. Fuel Supply Solenoid	7. Pressure Relief Valve
4. Fuel Supply Line	

30. Install the Multivalve cover and attach the 90-degree elbow to the pressure relief valve on the cover. Make sure the elbow is tight and leads to the driver's side of the vehicle, oriented toward the pressure relief hose.

**▲ Caution** — Hand tighten the 90-degree elbow to avoid cross threading. Failure to heed this caution can result in component damage.

**Note** — When installing the 90-degree elbow and brass tube to the Multivalve, use anti-seize on the threads prior to assembly.

31. Install the pressure relief hose to the 90-degree elbow and attach the spring clamp.

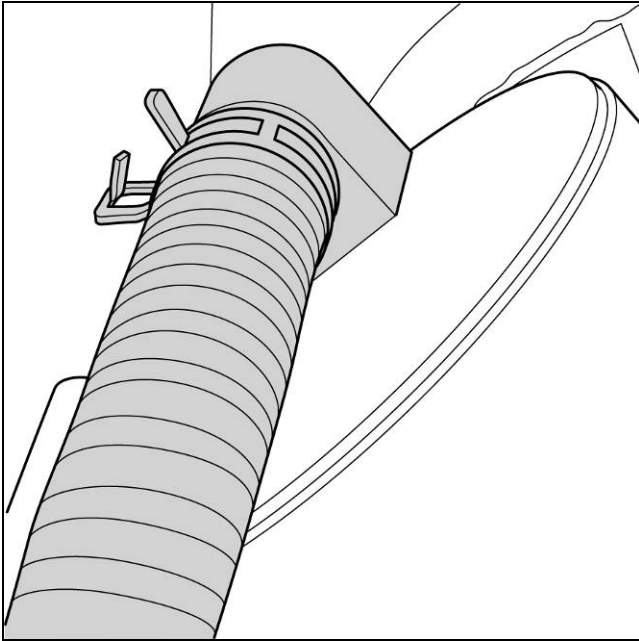

**Figure 81 — Spring Clamp and Pressure Relief Hose**

32. Install the negative battery cable.
33. Refer to the LPG System Bleed and Fill Procedure or follow the fuel tank documentation for the tank bleed and fill procedure. If there is no information provided with the tank, please contact ROUSH CleanTech Customer Service at 800-597-6874.
34. With Snoop®, or similar product, leak check the injectors, fuel rails and lines. Repair as necessary.
35. Start and run the engine and check for diagnostic trouble codes. Repair as necessary. Any questions, please contact ROUSH CleanTech Customer Service at 800-597-6874.

### **Installing In-Bed Tank**

**Note** — Before installing the in-bed tank into the vehicle, provide a place for prepping the tank for installation.

Because the tank collar around the Multivalve restricts access, connections to the Multivalve must be made before installing the tank in the truck bed.

1. Obtain a 5/8-11 threaded lifting eye and a hoist capable of safely lifting 1000 pounds.
2. Using an Allen key, remove the protective insert from the tapped weldment on top of the tank.
3. Install the lifting eye into the weldment.
4. Connect the off-tank fuel supply line to the quick connect fitting on the Multivalve.
5. Connect the off-tank fuel return line to the quick connect fitting on the Multivalve.
6. Assemble the fuel fill line on the Multivalve and tighten the connector to the specified torque.
7. Assemble the convolute tubing on the fuel fill line and the electrical cables.

**ROUSH® CleanTech F-250/F-350 Liquid Propane Injection  
Service Manual Supplement**

---

8. Assemble the convolute tubing on the off-tank fuel lines.
9. Assemble the shield onto the fuel tank and tighten the shield fasteners to the torque specified.

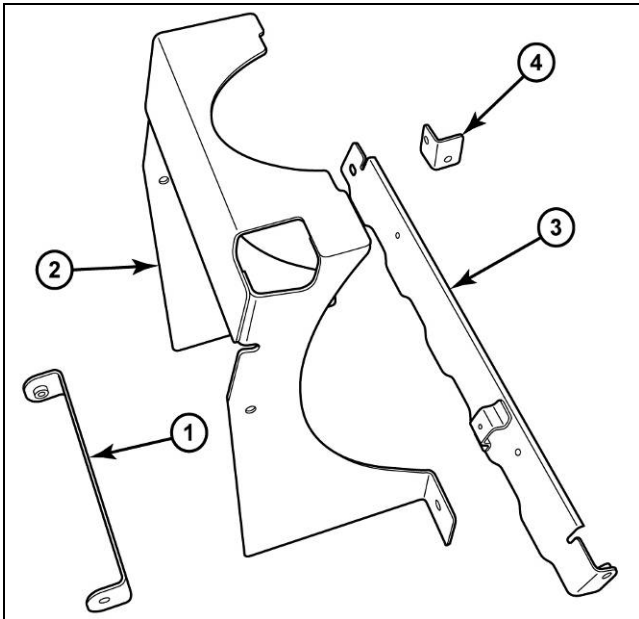

**Figure 82 — In-Bed Fuel Tank Shield Components**

1. Upper Cross Brace	4. Lower Cross Brace L Bracket (2 required)
2. Fuel Line Shield	
3. Lower Cross Brace	

10. With the help of an assistant, attach the hoist and position the tank onto the truck bed.

**▲ Caution** — The off-tank fuel lines attached to the Multivalve extend below the tank support weldments. Ensure that clearance is provided when resting the tank on any surface. Failure to heed this caution can result in component damage.

**▲ Warning** — Keep hands clear of the cross brace between the supports as the tank approaches the bed of the truck. Failure to heed this warning can result in serious personal injury.

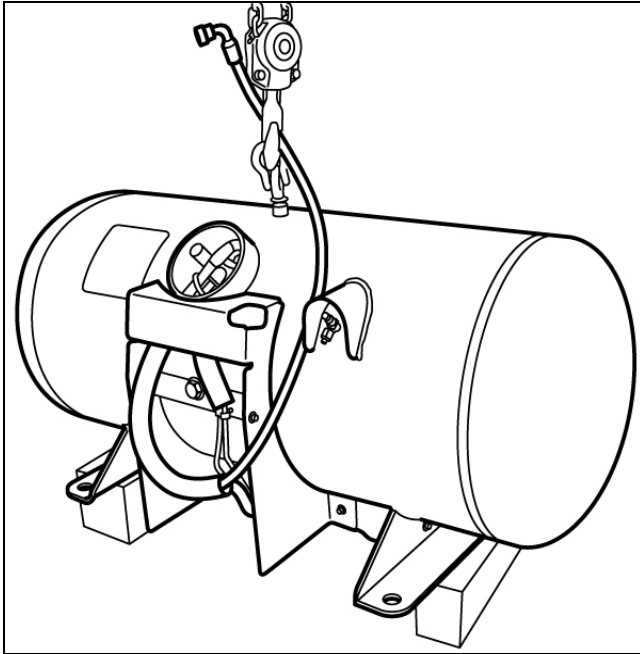

**Figure 83 — In-Bed Tank on Blocks**

11. Detach the hoist and remove the lifting eye.
12. Using an Allen key, install the protective insert in the weldment.
13. Assemble the nuts, steel washers and rubber isolators that attach the tank to the truck bed. Using a torque wrench, tighten the attaching nuts to the specified torque.
14. Connect the fuel tank electrical connector.

**Note** — Ensure that the wire colors are installed in their original locations.

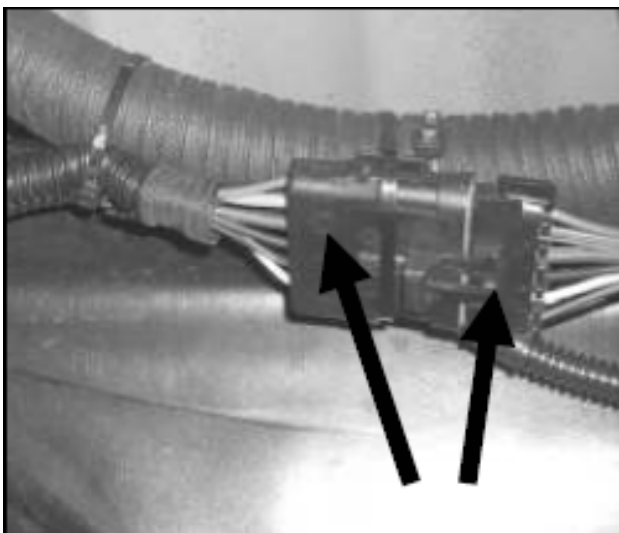

**Figure 84 — Fuel Tank Electrical Connector**

15. Connect the off-tank fuel lines to the intermediate fuel lines and tighten to the specified torque.

16. Attach the off-tank fuel lines to the retention clips. Connect the fuel fill line to the inlet of the fuel filter and tighten to the specified torque.

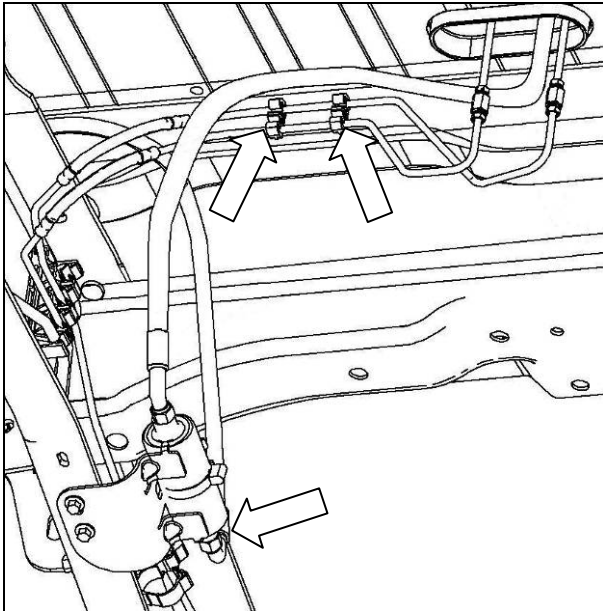

**Figure 85 — Fuel Lines**

17. Open the manual shutoff valve.
18. Attach the Multivalve cover.
19. Attach the 90-degree elbow to the Multivalve cover.
20. Attach the pressure relief hose to the 90-degree elbow.
21. Attach the pressure relief hose to the outlet nozzle at the fender support rod.

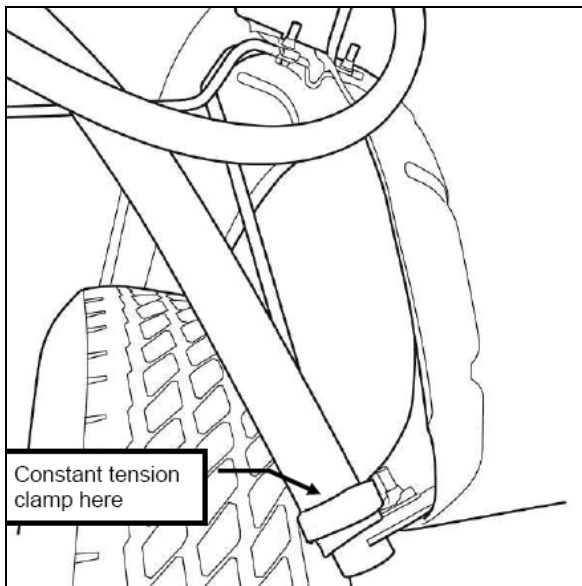

**Figure 86 — Pressure Relief Hose Lower Connection**

22. Connect the battery.

## ROUSH® CleanTech F-250/F-350 Liquid Propane Injection Service Manual Supplement

---

23. Refer to the LPG System Bleed and Fill Procedure or follow the fuel tank documentation for the tank bleed and fill procedure. If there is no information provided with the tank, please contact ROUSH CleanTech Customer Service at 800-597-6874.
24. With Snoop®, or similar product, leak check the injectors, fuel rails and lines. Repair as necessary.
25. Start and run the engine and check for diagnostic trouble codes. Repair as necessary. Any questions, please contact ROUSH CleanTech Customer Service at 800-597-6874.

### Fuel System Component Installation Procedures

Each of the following installation procedures is complete. If two or more procedures are required, they can be performed in any convenient order.

#### Before Installing Components

1. Ensure that the battery is disconnected.
2. Ensure that the ignition key is removed.
3. If the fuel tank is installed, ensure that the manual shutoff valve on the Multivalve is closed.

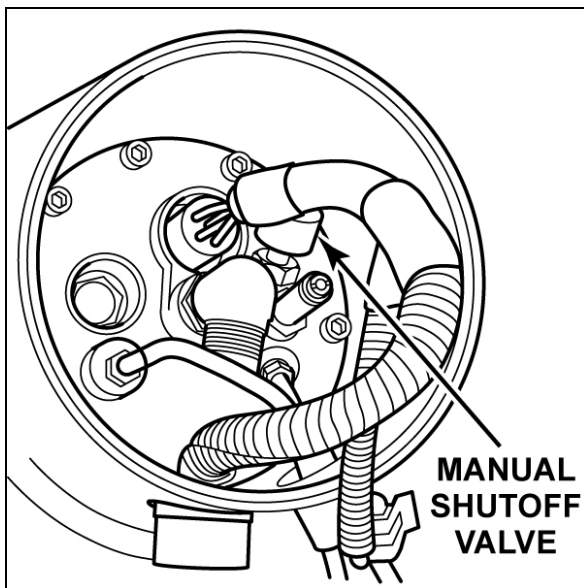

Figure 87 — Manual Shutoff Valve

### Installing Injection Pressure and Temperature Sensor

1. Install the Injection Pressure and Temperature Sensor (IPTS) into the left-side fuel rail.

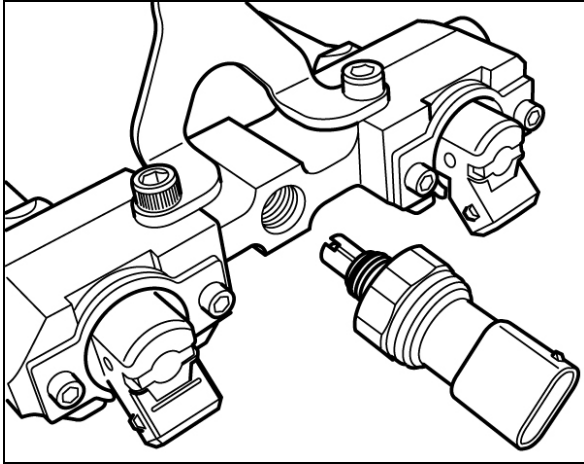

Figure 88 — Injection Pressure and Temperature Sensor

2. Connect the electrical connector to the IPTS.

### Installing Fuel Injector

1. Lubricate the upper and lower fuel injector O-rings using SAE 5w20 motor oil or equivalent.
2. Install the fuel injector into the fuel rail with a twisting motion so that the electrical connection faces the fender of the vehicle (opposite the intake manifold) when the injector is fully seated.
3. Install the fuel injector hold down bracket and bolts. Torque the fasteners to 3 N•m (27 lb-in). Install the fuel injector electrical connector.
4. Repeat the Removing Fuel Injector steps and Steps 1–3 of Installing Fuel Injector for the remaining fuel injectors as needed.

### Installing Right (Passenger's Side) Fuel Rail

**▲ Caution** — Hand tighten all fuel line connectors and fasteners before applying a wrench to avoid cross threading. Failure to heed this caution can result in component damage.

Assemble and lubricate new O-rings on the injector tips.

Position the right-side fuel rail assembly (with injectors) onto the passenger side of the intake manifold and fully seat the injector nozzles.

**▲ Caution** — Make sure the fuel injectors are correctly aligned with the intake manifold before seating. Failure to heed this caution can result in component damage.



1. Install and tighten the right-side fuel rail bolts to the specified torque.

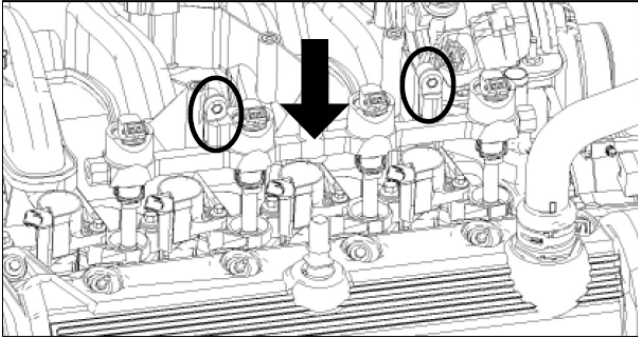

**Figure 89 — Right-Side Fuel Rail**

2. Connect the crossover fuel line to the right-side fuel rail and tighten to the specified torque.

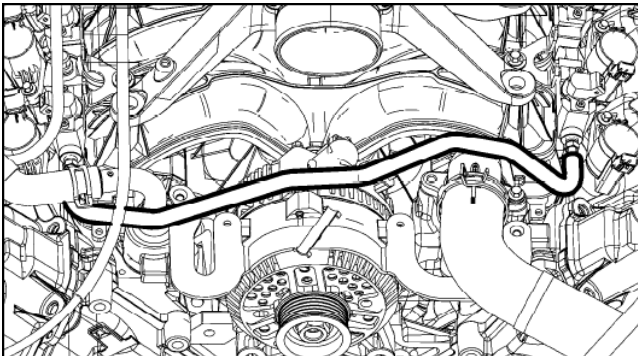

**Figure 90 — Crossover fuel Line**

3. Connect the fuel supply line at the rear end of the right-side fuel rail.
4. Connect the fuel injector electrical connectors.
5. Connect the PCV hose to the throttle body elbow.
6. If no additional assembly is required, open the manual shutoff valve and install the Multivalve cover, 90-degree elbow and pressure relief hose.
7. Connect the battery.

### Installing Left (Driver's Side) Fuel Rail

**▲ Caution** — Hand tighten all fuel line connectors and fasteners before applying a wrench to avoid cross threading. Failure to heed this caution can result in component damage.

1. Assemble and lubricate new O-rings on the fuel injector tips.
2. Position the left-side fuel rail assembly (with injectors) onto the driver side of the intake manifold and fully seat the injector nozzles.

**▲ Caution** — Make sure the fuel injectors are correctly aligned with the intake manifold before seating. Failure to heed this caution can result in component damage.

3. Install and tighten the fuel rail bolts to the specified torque.

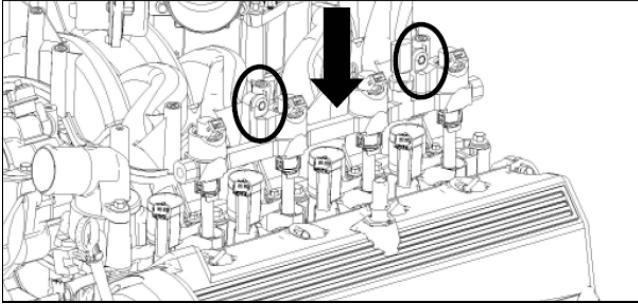

**Figure 91 — Left-Side Fuel Rail**

4. Connect the fuel return line at the rear end of the left-side fuel rail.
5. Connect the crossover fuel line to the left-side fuel rail and tighten to the specified torque.

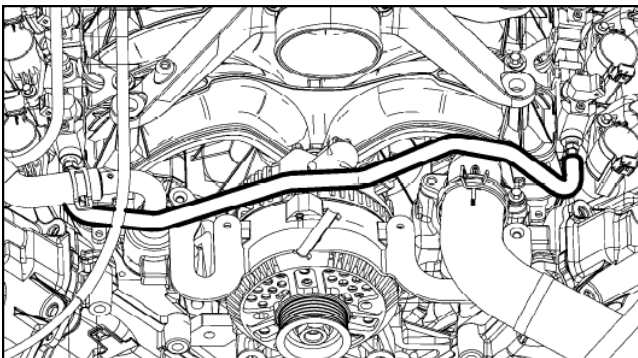

**Figure 92 — Crossover fuel Line, F-Series**

6. Connect the fuel injector electrical connectors.
7. Connect the Injector Pressure and Temperature Sensor (IPTS) electrical connector.

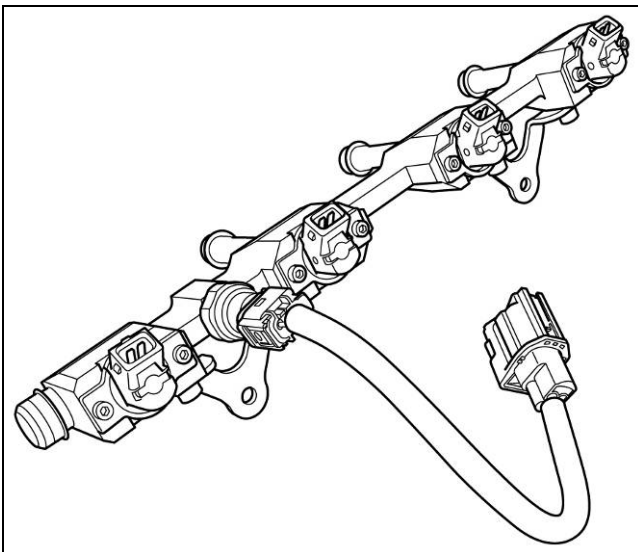

**Figure 93 — Fuel Rail with Injection Pressure and Temperature Sensor**

8. Connect the heated PCV hose to the intake manifold.
9. Attach the throttle body inlet hose.
10. Connect the Mass Air Flow sensor electrical connector.

## ROUSH® CleanTech F-250/F-350 Liquid Propane Injection Service Manual Supplement

---

11. If no additional assembly is required, open the manual shutoff valve and replace the Multivalve cover, 90-degree elbow and pressure relief hose.
12. Connect the battery.

### Installing Fuel Filter Assembly

1. Assemble the filter assembly in the screw clamp.
2. Tighten the clamp screw to the specified torque.
3. Connect the line from the filler neck to the inlet end of the fuel filter and tighten to the specified torque.
4. Connect the line from the tank to the outlet end of the fuel filter and tighten to the specified torque.

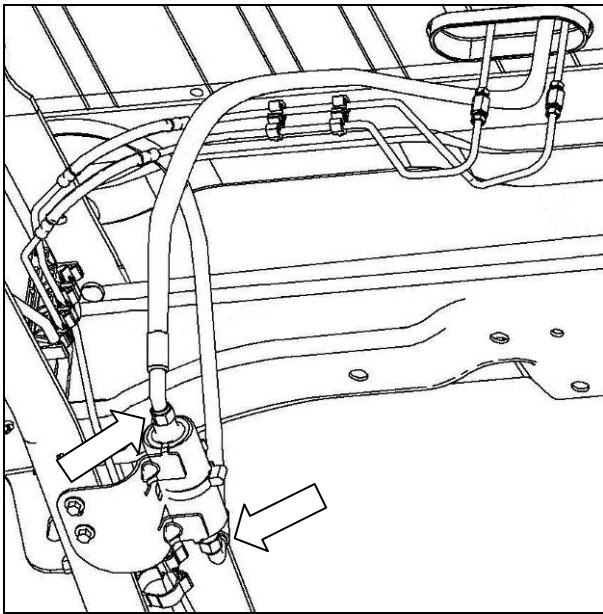

Figure 94 — Fuel Filter Assembly

5. If no additional assembly is required, open the manual shutoff valve and replace the Multivalve cover, 90-degree elbow and pressure relief hose.
6. Connect the battery.

### Installing Fuel Filler Neck

**▲ Caution** — Hand tighten all fuel line connectors and fasteners before applying a wrench to avoid cross threading. Failure to heed this caution can result in component damage.

**ROUSH® CleanTech F-250/F-350 Liquid Propane Injection  
Service Manual Supplement**

---

1. Attach the fill valve to the fuel filler neck mounting bracket. Install the nut and tighten to the specified torque.

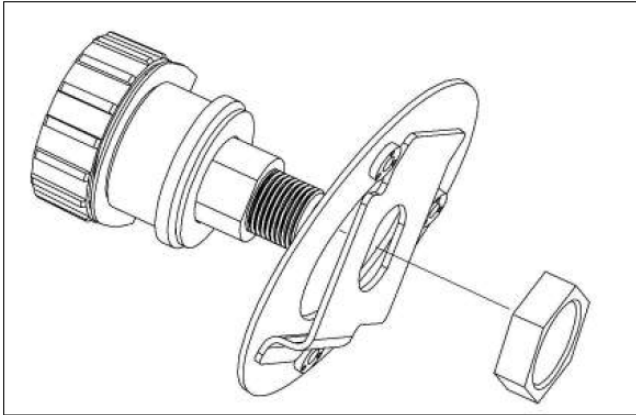

**Figure 95 — Fill Valve and Fuel Filler Neck Mounting Bracket**

2. Install the fill valve and fuel filler neck and mounting bracket to the vehicle side panel behind the vehicle fuel fill door. Install and tighten the bolts to the specified torque.

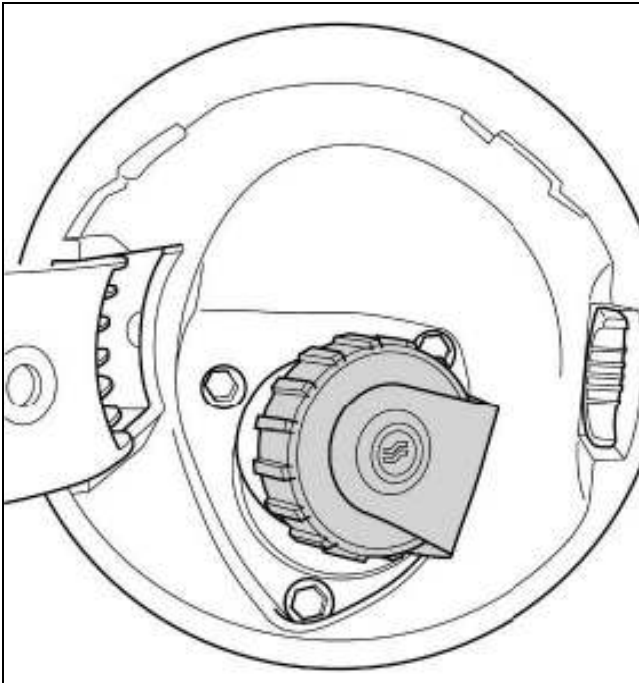

**Figure 96 — Fuel Filler and Door**

3. Install the fuel fill line to the fill valve and fuel filler neck.
4. If no additional assembly is required, open the manual shutoff valve and replace the Multivalve cover, 90-degree elbow and pressure relief hose.
5. Connect the battery.

### Installing Fuel Fill Line (Filler Neck to Filter)

1. Connect the fuel fill line to the filler neck.

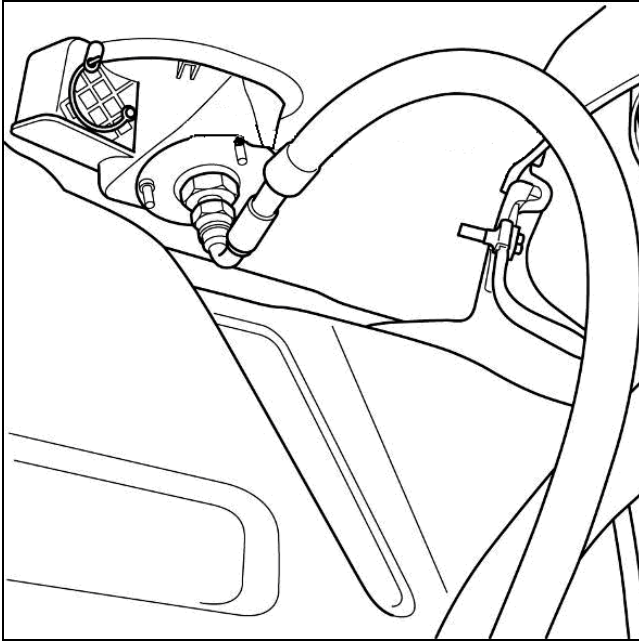

Figure 97 — Fuel Fill Line

2. Connect the fuel fill line to the inlet end of the fuel filter and tighten to the specified torque.
3. Install new cable ties as needed to secure the fuel fill line.
4. If no additional assembly is required, open the manual shutoff valve and replace the Multivalve cover, 90-degree elbow and pressure relief hose.
5. Connect the battery.

### Installing Fuel Fill Line (Fuel Filter to Tank)

1. With fuel tank removed for access, thread the fuel fill line fitting to its port on the tank and tighten to the specified torque.
2. Install the fuel tank and position the fuel fill line for correct routing.

3. Connect the fuel fill line securely to the outlet end of the fuel filter and tighten to the specified torque.

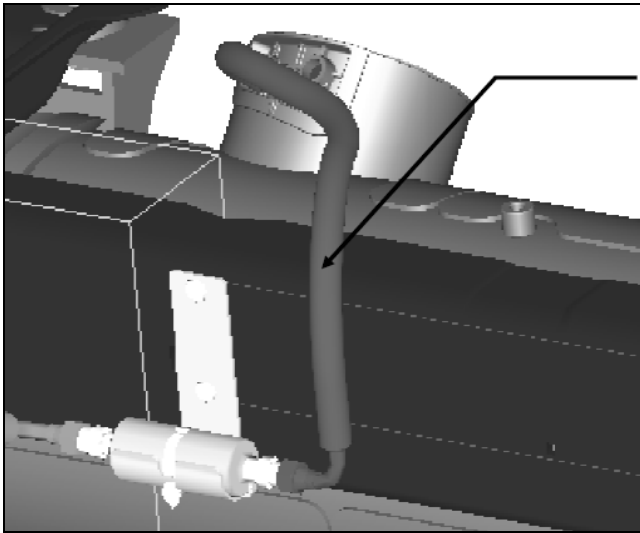

**Figure 98 — Fuel Fill Line (Filter to Tank)**

4. If no additional assembly is required, open the manual shutoff valve and replace the Multivalve cover, 90-degree elbow and pressure relief hose.
5. Connect the battery.

#### **Installing Fuel Lines (Solenoid to Engine)**

1. Align the forward fuel supply and fuel return lines along the frame rail on the driver's side.
2. Attach the forward fuel supply and fuel return lines to the retention clips along the frame rail and to the clips of the bracket on the transmission. Push the steel crimp of the fuel return line into the left clip and the rubber sleeve and fuel supply line into the right clip.
3. Install the forward fuel return line to the solenoid and tighten to the specified torque.
4. Install the forward fuel supply line to the fuel supply line coming from the fuel tank and tighten to the specified torque.
5. Push the forward fuel supply and fuel return lines into the quick connect fittings on the respective fuel rails.

#### **Installing Fuel Lines (Under-Vehicle Tank to Solenoid)**

**Note** — The fuel supply and fuel return lines quick connected into the fuel tank (Multivalve) are serviceable only with the fuel tank removed.

1. Align the tank fuel supply line with the forward fuel supply line, attach the fittings and tighten to the specified torque.
2. Align the tank fuel return line with the flow control solenoid, thread in the fitting and tighten to the specified torque.

3. Press the tank fuel lines with sleeves into the retention clips on the frame rail.

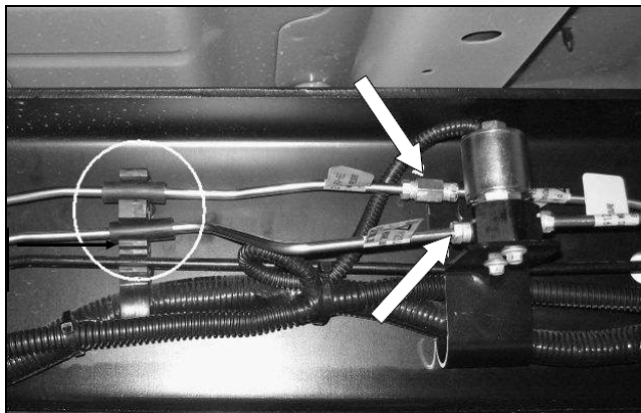

**Figure 99 — Tank Fuel Line Connections**

### **Installing Fuel Lines (In-Bed Tank to Solenoid)**

1. Attach the lines to the retention clips on the frame rail.
2. Connect the intermediate fuel supply line to the forward supply line (route lines behind the flow control solenoid). Tighten the fittings to the specified torque.
3. Connect the intermediate fuel return line to the rear fitting on the flow control solenoid and tighten to the specified torque.

### **Installing Flow Control Solenoid**

1. Assemble the solenoid onto the mounting bracket.
2. Using a torque wrench, tighten the attaching bolts to the torque specified.
3. Connect the intermediate and forward fuel return lines to the solenoid.

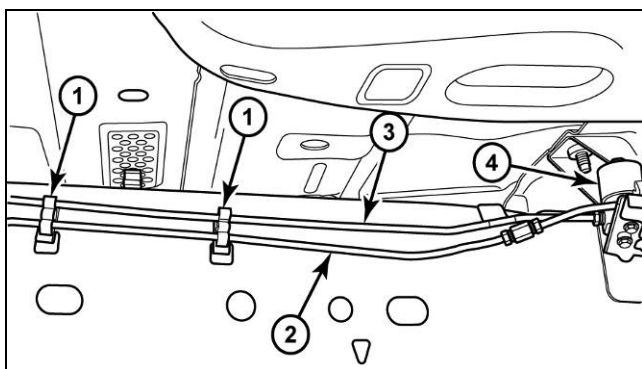

**Figure 100 — Fuel Lines (Typical)**

1. Retention Clip	3. Intermediate Fuel Return Line
2. Intermediate Fuel Supply Line	4. Flow Control Solenoid

4. Connect the flow control solenoid electrical connector.
5. If no additional assembly is required, open the manual shutoff valve and replace the Multivalve cover, 90-degree elbow and pressure relief hose.

6. Connect the battery.

### Installing Pressure Relief Hose

1. Connect the pressure relief hose to the 90-degree elbow in the Multivalve cover. Retain with spring clamp.
2. Connect the pressure relief hose to the outlet nozzle bracket at the fender support rod.

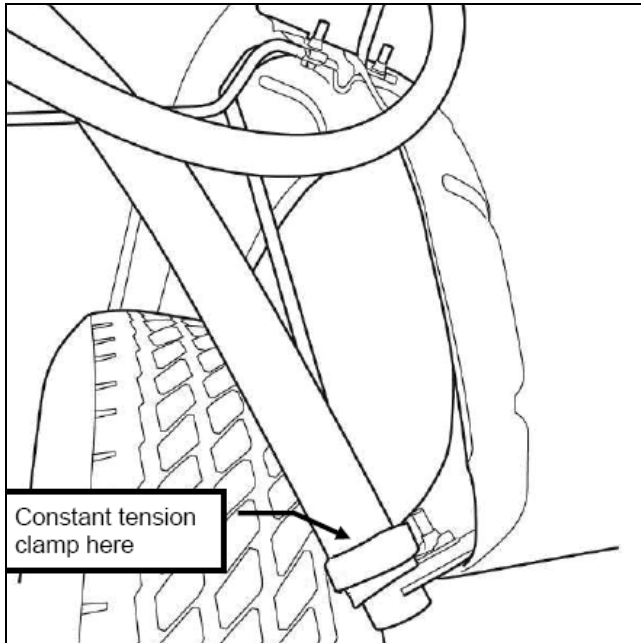

Figure 101 — Pressure Relief Hose Lower Connection



## SPECIFICATIONS

### Engine Specifications

#### Roush CleanTech Conversion Ford 5.4L LPI Engine

Bore and Stroke	90.2 mm x 105.7 mm
Compression Ratio	9.0:1
Displacement	5.4 Liters
Engine Architecture	V8 SOHC
Fuel System	Port Fuel Injection / Liquid Propane Injection
Peak Power Rating	300 HP
Peak Torque Rating	365 lb-ft
Transmission	4-Speed Automatic with Overdrive
Valve Operation	Variable Cam Timing
Valve Count	3 per cylinder
Valve Sizes	31.6 mm / 27.65 mm

#### Equipment

Air Conditioning	Standard
Heavy Duty Payload Package	Optional (Not available with Super Crew Cab)
Tires and Wheels	Variable with option package
Trailer Tow Package	Required

## Chassis Specifications

### Vehicles with In-Bed Tank

Model	Cab/Body Type	Wheelbase	
		6.75' Box	8.0' Box
F-250	Regular Cab	—	137"
	Super Cab	141.8"	158"
	Super Crew Cab	156.2"	172.4
F-350	Regular Cab	—	137"
	Super Cab	141.8"	158"
	Super Crew Cab	156.2"	172.4

### Vehicles with Under-Vehicle Tank

Model	Cab/Body Type	Wheelbase	
		6.75' Box	8.0' Box
F-250	Regular Cab	—	137"
	Super Cab	—	158"
	Super Crew Cab	—	172.4
F-350	Regular Cab	—	137"
	Super Cab	—	158"
	Super Crew Cab	—	172.4

**NOTE:** Vehicle dimensions are as quoted in the Ford Owner's Guide except that options are available only as shown in the following table.

**ROUSH® CleanTech F-250/F-350 Liquid Propane Injection  
Service Manual Supplement**

**Fastener Torque Values**

Fasteners, Fittings and Connections	Torque in N•m (Lb-Ft/Lb-In)	
	Under-Vehicle Tank	In Bed Tank
Flow Control Bracket-to-Frame M8 Nut	20-30 (15-22)	20-30 (15-22)
Flow Control Solenoid-to-Bracket M6 Bolt	8-12 (6-9)	8-12 (6-9)
Fuel Crossover Line Fittings	18-22 (13-16)	18-22 (13-16)
Fuel Fill Line Fittings	41-49 (30-36)	41-49 (30-36)
Fuel Filter and Bracket Assembly M8 Nut	20-30 (15-22)	20-30 (15-22)
Fuel Filter-to-Bracket Clamp	4-5 (35-44 lb-in)	4-5 (35-44 lb-in)
Fuel Line Nuts	41-49 (30-36)	41-49 (30-36)
Fuel Line Shield Cross Brace M8 Bolt	—	20-30 (15-22)
Fuel Rail Mounting Bolt	8-12 (6-9)	8-12 (6-9)
Fuel Supply and Return Line Fittings	18-22 (13-16)	18-22 (13-16)
Fuel Tank Lower Cross Brace M8 Bolt	—	20-30 (15-22)
Fuel Tank Tank-to-Mounting Plate M12 Nut	—	80-90 (59-66)
Fuel Tank Mounting Bracket (Plate-to-Bed) M14 Bolt	—	100-110 (74-81)
Fuel Tank Upper Cross Brace 5/8-inch Bolt	—	145-155 (107-114)
Fuel Tank Lower Cross Brace M8 Bolt	—	20-30 (15-22)
Fuel Tank Fuel Line Side/Upper Shield M8 Bolt	—	20-30 (15-22)
Fuel Tank Front Outboard Frame Bracket M8 Bolt	20-30 (15-22)	—
Fuel Tank Front Outboard Frame Bracket M10 Bolt	40-55 (30-41)	—
Fuel Tank Rear Outboard Frame Bracket M10 Bolt	40-55 (30-41)	—
Fuel Tank Crossmember Mounting Bracket-to-Tank (Front/Rear) M12 Bolt/Nut	80-90 (59-66)	—
Fuel Tank Crossmember Mounting Bracket-to-Crossmember (Rear) M10 Nut	40-55 (30-41)	—
Fuel Tank Crossmember Mounting Bracket-to-Crossmember (Front) M10 Nut	40-55 (30-41)	—
Fuel Tank Mounting Bracket (Outboard) M12 Bolt/Nut (Front/Rear)	80-90 (59-66)	—
Fuel Tank Midship Bearing Bracket-to-Front Crossmember M12 Bolt/Nut (Crew Cab/Super Cab)	80-90 (59-66)	—
Fuel Tank Midship Bearing Bracket-to-Front Crossmember Bracket M10 Bolt/Nut (Crew Cab/Super Cab)	40-55 (30-41)	—
Fuel Tank Midship Bearing-to-Midship Bearing Bracket at Front Crossmember M10 Bolt/Nut (Crew Cab/Super Cab)	40-55 (30-41)	—
Fuse Box Bracket M6 Bolt	8-12 (6-9)	8-12 (6-9)
Fuse Box Bracket M6 Nut	8-12 (6-9)	8-12 (6-9)
Fuse Box-to-Bracket M6 Nut	8-12 (6-9)	8-12 (6-9)
Multivalve Cover M24 Nut	Snug Tight	
Multivalve-to-Tank M6 Screw	5.5 (49 lb-in)	5.5 (49 lb-in)
Pressure Relief Hose Support Rod Bolt	8-12 (6-9)	8-12 (6-9)
Fill Valve Bracket Assembly M5 Bolt	5-7 (44-62 lb-in)	5-7 (44-62 lb-in)
Fill Valve-to-Bracket Nut	Snug Tight	
Injection Pressure and Temperature Sensor (IPTS)	6-8 (53-71 lb-in)	6-8 (53-71 lb-in)

## SCHEMATICS

### Fuel System Flow Diagrams

#### Fuel Flow

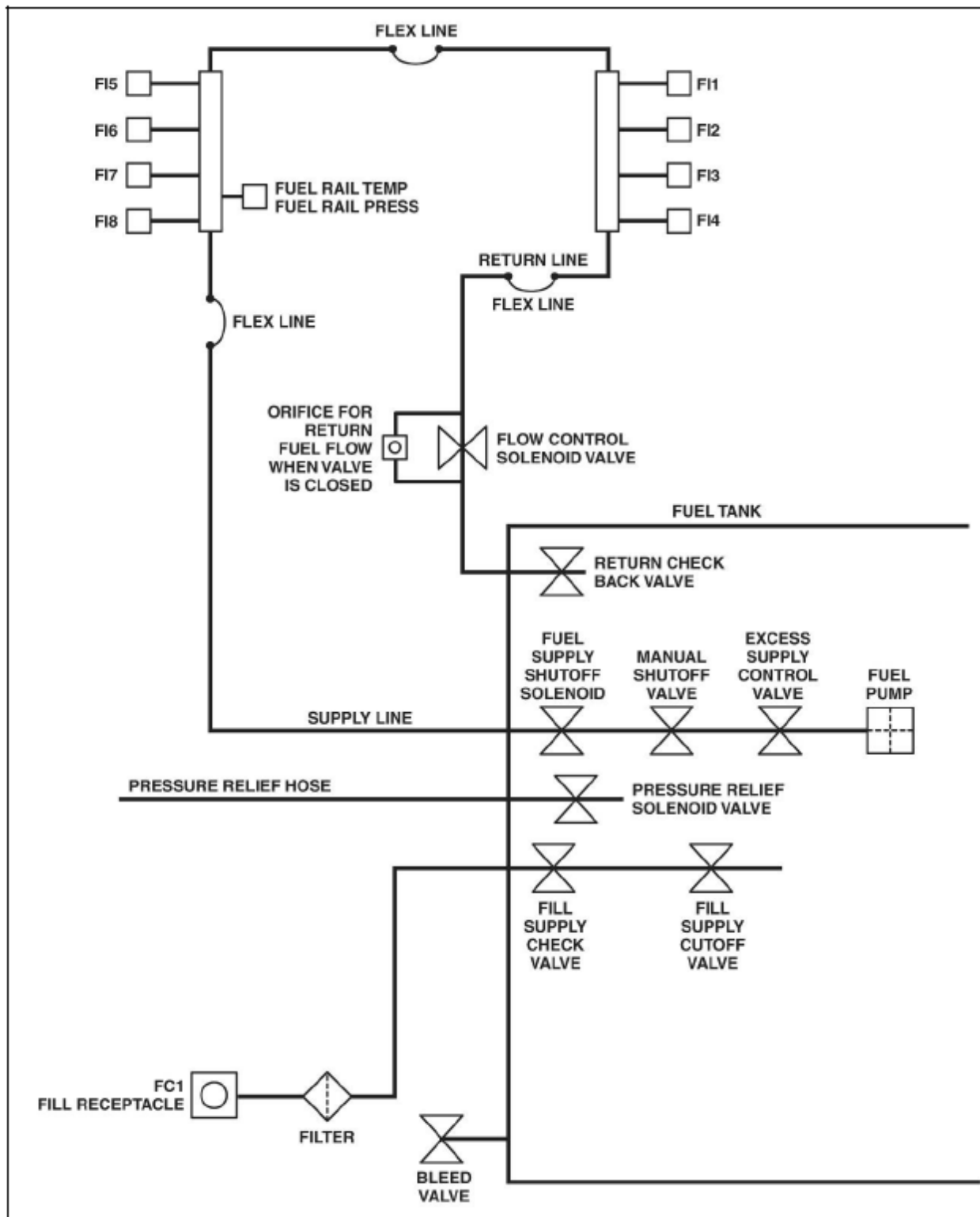

## Electrical Wiring Diagrams

### Wiring Schematic

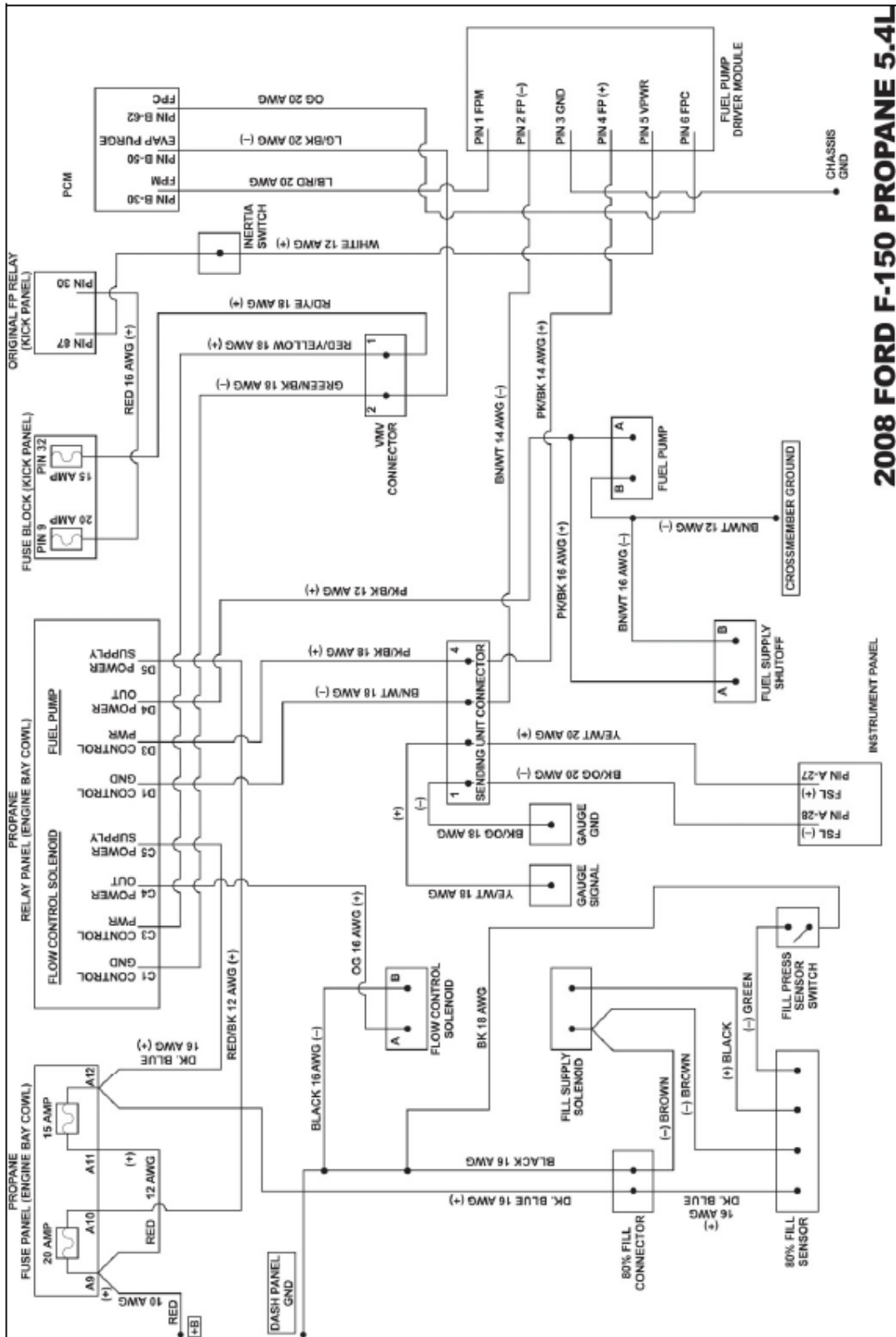

2008 FORD F-150 PROPANE 5.4L

INSTRUMENT PANEL

# ROUSH® CleanTech F-250/F-350 Liquid Propane Injection Service Manual Supplement

## Vehicle Harness

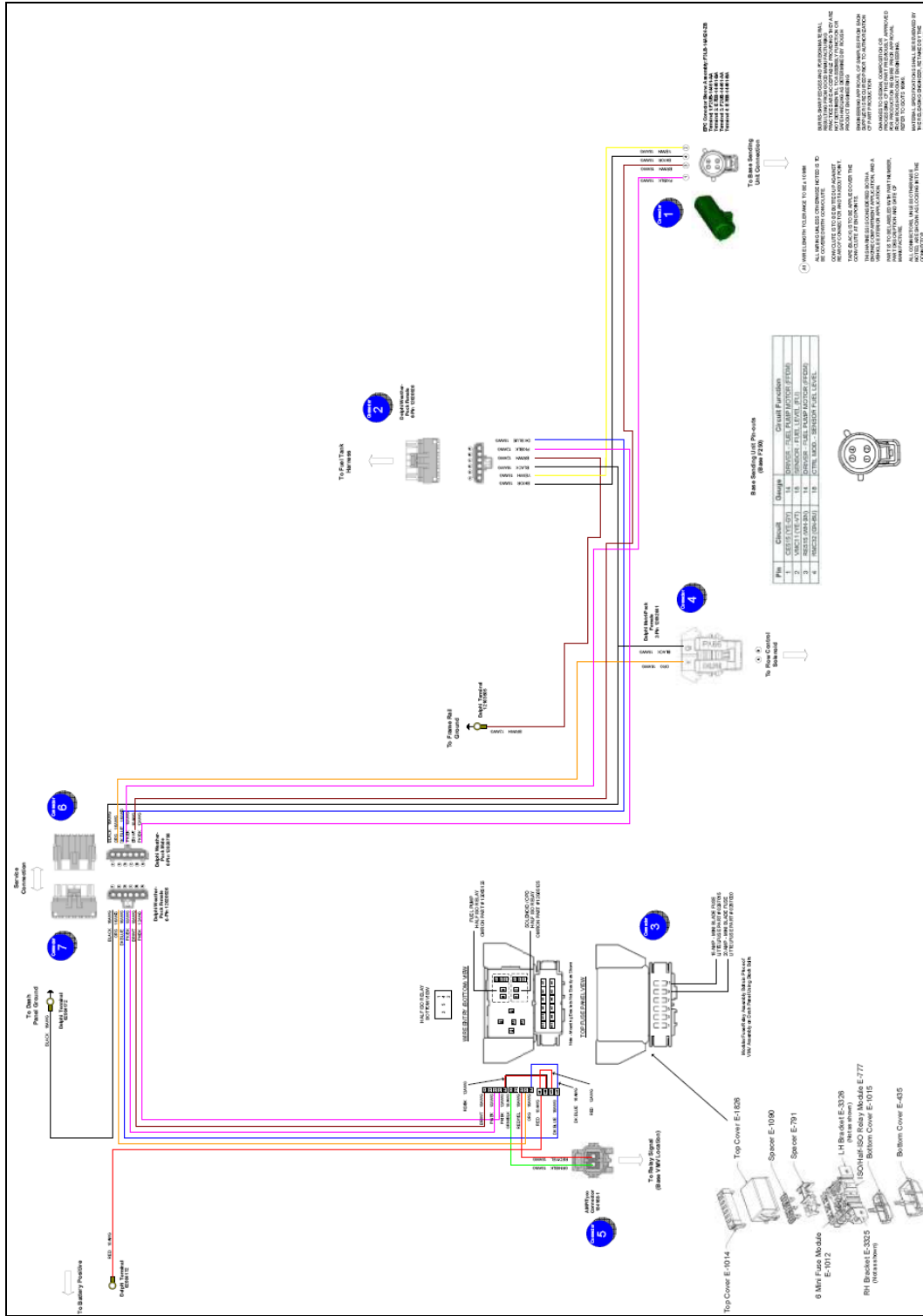

**ROUSH® CleanTech F-250/F-350 Liquid Propane Injection  
Service Manual Supplement**

**In-Tank Wire Harness**

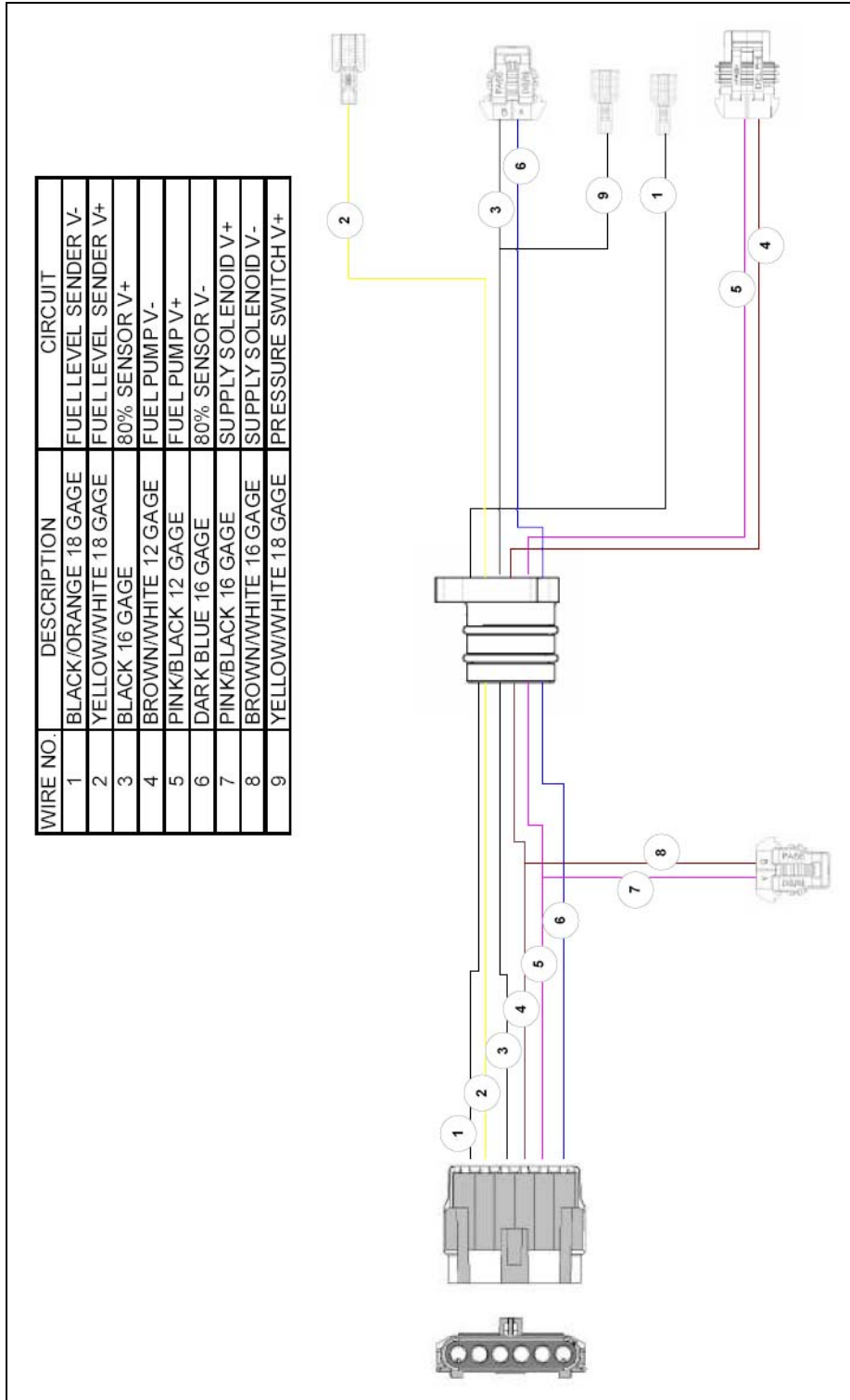

For an updated version of the in-tank wiring harness, visit the ROUSH CleanTech web site at <http://service.roushcleantech.com>.

## TOOLS AND EQUIPMENT

### Special Tools

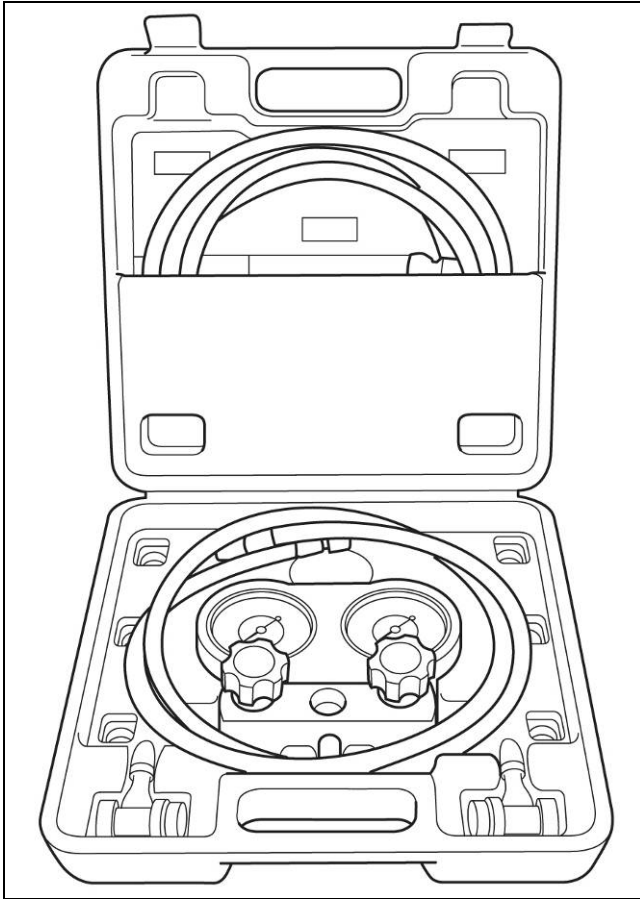

**Fuel Pressure Gauge Kit (0–500 psi)**

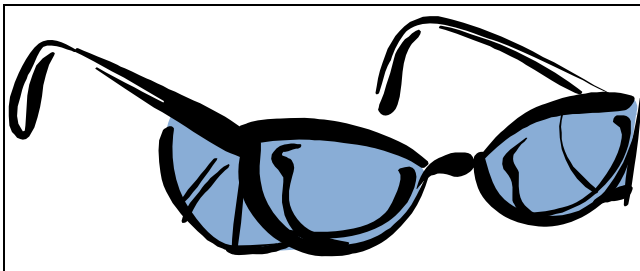

**Safety Glasses**



**ROUSH® CleanTech F-250/F-350 Liquid Propane Injection  
Service Manual Supplement**

---

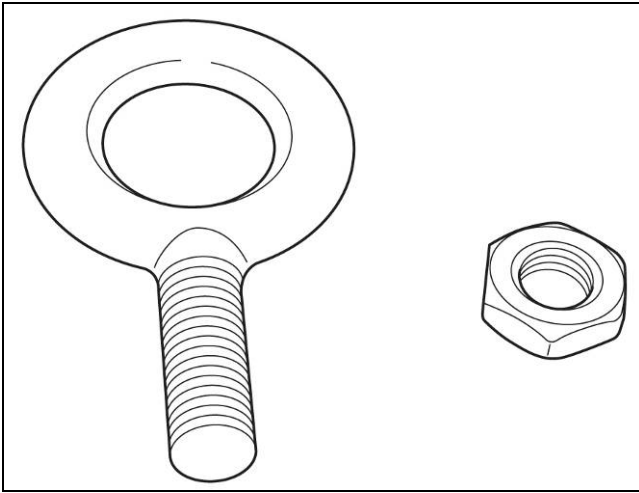

**Eyebolt and 5/8"-11 Locknut**

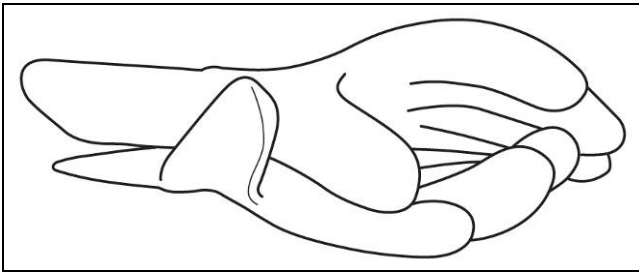

**Gloves (Approved for Propane)**

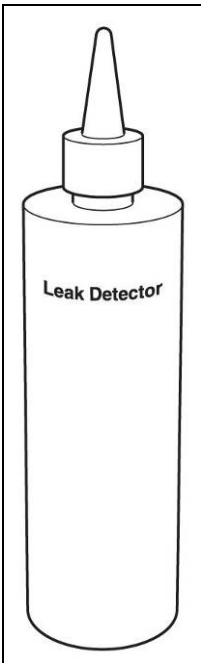

**Liquid Leak Detector**