

2016

Ford F-650, F-750, F-59

Gen 4 Liquid Propane Autogas Fuel System

Includes:

F-650, F-750, F-59

May, 2016

SERVICE MANUAL

FOREWORD

This manual is intended to provide technicians with the procedures required to maintain and service the unique components of the ROUSH CleanTech Liquid Propane Autogas (LPA) system. Service procedures for other vehicle components may be referenced to, which can be found in the *Ford Workshop Manual* or *Ford Powertrain/Emissions Diagnosis Service Manual*. For access to the Ford manuals, please subscribe to www.motorcraft.com.

 **WARNING**

Technicians working with, or around fuel systems should be properly trained to utilize extreme care and caution at all times. Failure to exercise extreme caution and care may lead to serious accidents which can result in property damage, personal injury and/or death.

INTRODUCTION	1	Electronic Fuel Pump Relay (EFPR)	16
GENERAL INFORMATION	1	Smart Relay Module/LPA Gateway Module.....	16
Liquid Propane Autogas Fuel System Overview	1	LPA Interface Function.....	16
ROUSH CleanTech Technical Assistance	1	GLOSSARY	16
Propane.....	1	MAINTENANCE	18
Fill Stations.....	1	MAINTENANCE REQUIREMENTS	18
SAFETY INFORMATION	2	Intake Air Assembly.....	18
Alert Messages.....	2	In-Line Fuel Filter Replacement	18
Installation, Garaging and Training.....	3	REPAIR PROCEDURES	19
Purging and Venting (Tanks and Lines)	3	PREPARING VEHICLE FOR SERVICE	19
VEHICLE INFORMATION	3	Alert Messages.....	19
Build Data.....	3	Manual Fuel Shutoff	19
DESCRIPTION AND OPERATION	5	Tank Cover Plate	20
LIQUID PROPANE AUTOGAS FUEL SYSTEM		Fuel Line Purging and	
OVERVIEW	5	Fuel Tank Draining Procedures	20
Fuel System Design	5	Using In-Tank Pumps	22
Start Sequence	7	FUEL SYSTEM COMPONENT SERVICE	23
General Propane Tank Filling Procedure.....	8	Fuel Tank	23
Propane Powered Motor Vehicle Filling Overview	8	Fuel Tank Pressure Relief Valve	26
Vehicle Filling Procedure	9	Tank Supply Valve Assembly.....	26
LPA FUEL SYSTEM COMPONENTS		Fuel Tank Return Valve.....	27
AND FUNCTION	10	Tank Bleeder Valve	28
Propane Fuel Tank.....	10	Fuel Pump Assembly (In-Tank).....	29
Tank Fill Valve/Overfill Protection Device	11	Fuel Level Sender.....	30
Fuel Pumps	12	Fuel Tank Wiring.....	31
Tank Pressure Temperature Sensor	12	Mechanical Fill Valve/Overfill Protection Device	31
Fuel Level Sender.....	12	Fuel Fill Line (Fuel Fill Valve-to-Filter).....	34
Tank Bleeder Valve/Fixed Liquid Level Gauge	12	Fuel Fill Line (Filter-to-Tank)	35
Pressure Relief Valve.....	13	Fuel Filler Valve (ACME)	36
Tank Supply Circuit Assembly	13	Fuel Filler Valve (EURO).....	36
Tank Solenoid Valve	13	In-Line Fuel Filter.....	37
Manual Shutoff Valve.....	13	Supply Filter	38
Excess Flow Valve (XFV)	13	Fuel Supply and Return Lines.....	39
Fuel Return Circuit Assembly.....	13	Rear Supply and Return Lines	39
Fuel Lines	14	F-59 Only.....	41
Fuel Rail Pressure Control Module (FRPCM)	14	Crossover Fuel Fill Line and Transfer Line	
Injection Pressure Temperature Sensor	15	(F-650 Dual Tanks Only)	42
Vapor Canister Assembly	15	Intermediate Supply and Return Lines	
Vapor Lines.....	15	(F-59 Only).....	43
Fuel Rail Assemblies	15	Forward Supply and Return Lines.....	44
Remote Fill Valve	15	Fuel Rail Pressure Control Module.....	46
Fill Line	15	Fuel Rail Service.....	48
Fuel Fill Filter	15	Fuel Injector.....	49

TABLE OF CONTENTS

Injection Pressure Temperature Sensor	50
Smart Relay Module.....	51
Tank Pressure Temperature Sensor	53
PREPARING VEHICLE FOR USE	
AFTER SERVICE.....	53
Operating the Manual Shutoff Valve.....	53
Fuel Tank Purging Procedure	54
Fuel System Priming Procedure.....	54
SPECIFICATIONS.....	55
Torque Chart.....	55
TOOLS	57
TOOLS AND EQUIPMENT	57
Special Tools	57
Quick Disconnect Tools	57
Electronic Leak Detector	57
Flare Tower.....	57

INTRODUCTION

GENERAL INFORMATION

Liquid Propane Autogas Fuel System Overview

This manual is a supplement to the regular Ford Workshop Manual, covering the unique components of the ROUSH CleanTech Liquid Propane Autogas (LPA) fuel system. Unlike the traditional propane-powered vehicle that supplies propane to the engine in a vapor form, the LPA system delivers, meters and injects liquid propane into the engine.

Similar to a modern gasoline engine, the LPA system stores liquid propane in the fuel tank. Dual in-tank electric fuel pumps circulate the propane through fuel rails which supply fuel to the fuel injectors. The injectors meter and inject liquid propane into each of the original inlet ports on the Ford engine. Fuel that is not used by the injectors will return to the fuel tank through a flow control solenoid.

The ROUSH CleanTech LPA system is fully integrated using Ford's one touch integrated start (OTIS) system. When the ignition key is turned to START and released to the ON position, the LPA system runs a purge process, then the starter engages and the vehicle starts with no further action required from the operator.

Fueling a propane-powered vehicle is noticeably different than on a conventional-fueled vehicle. A propane fuel system is completely sealed and the major difference is the screw-on type fill connector used for propane. When fueling, turn connector clockwise to tighten, ensuring a good seal at the fill valve. The tank is equipped with an automatic stop fill device, which only allows the tank to be filled to 80% of the overall tank volume, leaving room for the fuel to expand and contract. At the 80% fill level, the instrument cluster fuel gauge will read full. When using a facility designed for automotive fueling, the fill time is similar to refueling a diesel-powered vehicle.

ROUSH CleanTech Technical Assistance

Call ROUSH CleanTech Customer Service at 1-800.59.ROUSH (597-6874) with any questions regarding ROUSH CleanTech Liquid Propane Autogas systems.

Propane

Propane exists as a gas at normal atmospheric pressure, and like diesel fuel, gasoline or natural gas, is a member of the hydrocarbon family. Propane is a by-product of refined petroleum and natural gas.

When stored under pressure, propane turns into a liquid. Propane is colorless, odorless and non-toxic. Ethyl mercaptan is added to propane during the manufacturing process to give it a distinct, recognizable odor.

Propane is commonly referred to as LPG or LP gas. Like most liquids, liquid propane expands as its temperature increases. This is why a propane tank is only filled to 80% of its liquid capacity. Even with an 80% fill capacity, due to liquid propane's expansion ratio of 1:270 (liquid propane to a gas by volume) and its high BTU rating, a large volume of energy can be stored in a relative small tank under relative low pressure.

Propane also has a very narrow range of flammability with a 2.15% threshold on the low side and a 9.6% threshold on the high side. This means that if the propane-to-oxygen mixture is lower than 2.15% or higher than 9.6%, the mixture is noncombustible.

Propane is heavier than air; therefore, a leak in a propane fuel system can result in gas accumulation in low places, such as sewers, drains or service pits. This can create a fire and health hazard as the propane will displace oxygen, potentially resulting in suffocation. For this reason, additional safety precautions should be observed when working on or around propane-powered equipment or storage tanks.

Propane is stored in the vehicle fuel tank under pressure as a liquid. The pressure in the tank is determined by the temperature of the fuel, ranging from 0 psi (0 kPa) at -44°F (-42°C), to 312 psi (2152 kPa) at 145°F (63°C). The tank has an overpressure safety device which vents the tank at pressures over 312 psi (2152 kPa). ROUSH CleanTech LPA vehicles require HD-5 propane, rated for automotive use. Use of HD-10 or other substandard propane may result in excess contamination of the system and premature failure of the fuel pump, injectors and in-tank filters.

Fill Stations

Propane is readily available anywhere in the United States. To locate the nearest station, check with <http://www.afdc.energy.gov/afdc/locator/stations/> ROUSH CleanTech recommends facilities designed for automotive refueling. Other locations may have low output pumps, resulting in slow or no fill, or low quality fuel which can result in premature component failure.

! WARNING

ROUSH CleanTech does not approve of any additions to, or modifications of, this fuel system. This fuel system is designed and installed to meet federal standards and engine manufacturer's guidelines. The maintenance provider or modifier assumes all responsibility for the vehicle engine and fuel system if the fuel system is changed or modified. Some states require a special license to perform maintenance or work on propane-powered vehicles. Check with local authorities or your state LP Gas Association for details. All fuel system components must be a minimum of 18 inches from any exhaust system component unless properly shielded. All service, maintenance and repairs performed on LP gas systems must be done by a ROUSH CleanTech-trained and certified service technician as required by state or local regulations.

SAFETY INFORMATION

The National Fire Protection Association (NFPA) publishes a code book of rules that apply to the storage, handling, transportation and use of liquefied petroleum gas (LP-Gas or LPG). The book is known as NFPA 58. It is revised as necessary and published every other year. This code is adopted as law in virtually every political subdivision in the United States. Check with your local authorities for regulations applicable to liquid propane.

Alert Messages

The following alert messages appear from time to time in appropriate places in this manual. Ensure that all personnel in the immediate area are aware of these reminders.

! DANGER

Propane is nontoxic, nonpoisonous, has the lowest flammability range of any alternative fuel and dissipates quickly when released into the atmosphere. When the ratio of propane to air is between 2.2% and 9.6%, propane will burn in the presence of an ignition source at 940°F (504°C) or hotter. Keep away from heat, sparks, flames, static electricity or other sources of ignition. Failure to heed this danger may result in severe personal injury or death.

! DANGER

The fuel supply lines remain pressurized after engine shutdown. Keep away from heat, sparks, flames, static electricity or other sources of ignition. Do NOT enter storage areas or confined space unless they are adequately ventilated. Failure to heed this danger may result in severe personal injury or death.

! DANGER

Do NOT carry lighted smoking materials or smoke while working on fuel system components. Failure to heed this danger could result in severe personal injury or death.

! DANGER

Disconnect the battery ground at the battery to ensure that the vehicle electrical system has no current. Failure to heed this danger could result in severe personal injury or death.

! DANGER

Propane is heavier than air and seeks the lowest available level when released to the atmosphere. Keep heat, sparks, flames, static electricity or other sources of ignition out of the area when venting or purging the fuel lines or tank. Failure to heed this danger can result in severe personal injury or property damage.

! DANGER

Technicians working with, or around, fuel systems should be properly trained to utilize extreme care and caution at all times. Failure to exercise extreme caution and care may lead to serious accidents which can result in property damage, personal injury and/or death.

! WARNING

Liquid propane is cold. The temperature of propane in its liquid state at atmospheric pressure is -44°F (-42°C). Wear eye and ear protection during venting and repair operations. Keep moisture away from the valves. Failure to heed this warning can result in personal injury.

Installation, Garaging and Training

Chapter 11 of NFPA 58 applies to engine fuel systems using LP-Gas in internal combustion engines, including containers, container appurtenances, carburetion equipment, piping, hose and fittings and their installation. Additionally, this chapter applies to garaging of vehicles and to the training of personnel Paragraph 11.2 specifies that each person engaged in installing, repairing, filling or otherwise servicing an LP-Gas engine fuel system shall be trained. Contact the Propane Education and Research Council to learn more about their CETP E-Learning computer-based training program: courtney.gendron@propanecouncil.org, or vincent.sibilia@propanecouncil.org.

Purging and Venting (Tanks and Lines)

Venting of LP-Gas to the atmosphere is covered by paragraphs 7.3.1, General, and 7.3.2, Purging of NFPA 58, 2008 edition. Refer to NFPA 58, Local Codes and Proper Training for specific information relating to safe venting of LPG.

VEHICLE INFORMATION

Build Data

ROUSH CleanTech emissions certification information is recorded on the Roush CleanTech Vehicle Emissions Control Information (VECI) labels. The labels are vehicle-specific and are required by law to be on the vehicle to which it is assigned along with the Ford VECI label.

This vehicle is classified as a heavy duty engine (HDE) certification. This requires that VECI labels be displayed on the hood, body and engine locations.

VEHICLE EMISSIONS CONTROL INFORMATION LABEL

ROUSH.	ROUSH INDUSTRIES VEHICLE EMISSIONS CONTROL INFORMATION
Conforms to regulations: 2011 MY INCOMPLETE LPG Weight limits refer to Emission Certification only DO NOT EXCEED VEHICLE GVWR (See Incomplete Vehicle Manual)	
U.S. EPA: T2B5 HDV1 OBD: CA II Fuel: LPG	
California: SULEV II qualified MDV OBD: CA II Fuel: LPG	
Completed Vehicle Maximums: GVWR: 9600# max CurbW: 6949# max. Frontal Area: 60.0 ft2 max.	
No adjustments needed	TWC/HO2S/SFI/HAFS
5.4L-Group: BRIIT05.45HK Evap: BRIIF0265LPG	▽ P11C2-9C485-DA

100001a

Figure 1 – ROUSH CleanTech VECI Label (Typical)

	Ford Motor Company VEHICLE EMISSION CONTROL INFORMATION
Conforms to regulations: 2008 MY FFV	
U.S. EPA: IT2B8 LDT4 OBD: F II Fuel: Gasoline/Ethanol	
California: Not for sale in states with California emissions standards.	
TWC/HO2S/SFI No adjustments needed.	
5.4L-Group: 8FMXT05.44HF Evap: 8FMXR0250NBR	
▽8W7E-9C485-R R L	SAMPLE

100002a

Figure 2 – Ford VECI Label (Typical)

VECI LABEL HOOD LOCATION

The ROUSH CleanTech VECI label appears along with the original Ford VECI label under the hood.



Figure 3 – VECI Label Location (Typical Placement)

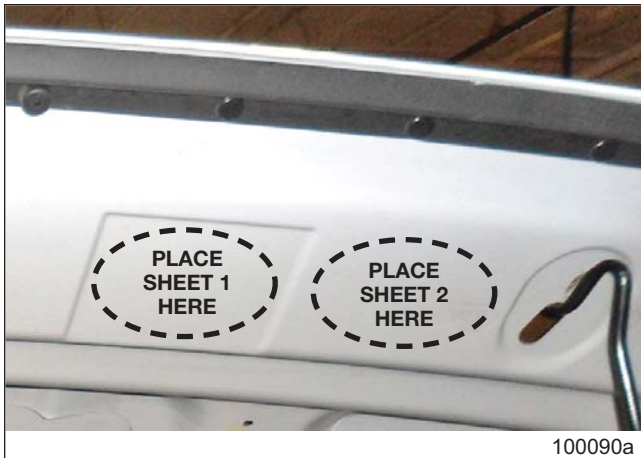

100090a

Figure 4 – Place Sheets as Applicable



100584a

Figure 6 – F-59 VECI Label Body Location

HEAVY DUTY ENGINE CERTIFICATION APPLICATIONS

If your PCM was returned to you with two copies of the VECI label, then your vehicle is classified as a HDE certification. However, the engine label(s) should be installed on the side of the oil pan on the LH (driver) side of the vehicle between the oil filter and oil pan as shown (Figure 5). HDE certifications require that an additional (identical) label be attached to the engine as well as the vehicle body.

For HDE applications, the vehicle label should be installed to the body as described above. For the additional label, follow the same preparation and installation procedures previously defined.



100582a

Figure 7 – F-650/750 VECI Label Body Location – Passenger Side

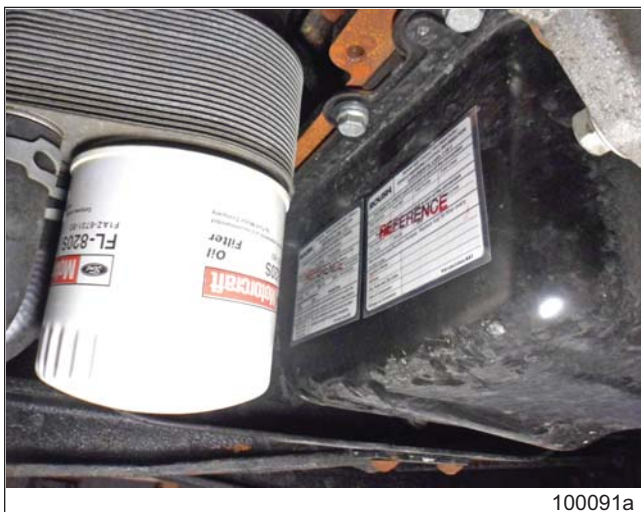

100091a

Figure 5 – VECI Label Installation: Oil Pan on HDE Vehicles ONLY (Image typical – actual vehicle may vary)



100583a

Figure 8 – F-650/750, F-59 VECI Label Oil Pan Location – Passenger Side Oil Pan

LIQUID PROPANE AUTOGAS FUEL SYSTEM OVERVIEW

Fuel System Design

The Ford 6.8L 3-valve engine fuel supply is controlled by the powertrain control module (PCM); however the fuel control calibration has been optimized for propane. The PCM sends commands to the smart relay module (SRM) which controls the fuel system solenoids.

Electronic fuel pump relays (EFPR) control the dual fuel pumps inside the tank to deliver liquid propane to the injectors. From the pumps, the fuel flows through the supply solenoid (on the tank), into the 3/8" fuel supply line, to the supply solenoid on the fuel rail pressure control module (FRPCM), then to the fuel rails and injectors. Excess fuel flows back to the tank through the FRPCM flow control solenoid (FCS), into the 1/4" fuel return line and through the return check valve on the fuel tank. Fuel pressure is regulated by the FCS which includes a small orifice to restrict return flow in normal conditions; and a bypass circuit to allow maximum fuel flow prior to engine starting or during extremely hot conditions.

The FRPCM also contains a bleed solenoid to control the flow of fuel vapors from the fuel rail to the carbon canister during engine off conditions. The engine vapor management valve (VMV) controls the purging of the vapor canister, sending the vapors back into the intake manifold for the engine to consume.

The filling process is safeguarded against overfilling by an 80% overfill protection device (OPD) integral to the liquid propane autogas (LPA) system fuel fill valve on the tank. In order to safely store pressurized liquid propane in the vehicle, the fill system must be designed so that the tank is not filled beyond 80% of its total volume. This ensures that sufficient expansion volume is present in case of significant tank temperature changes.

The LPA tank stores the liquid propane under pressure. Internal to the tank are dual electric fuel pumps, fuel pump housing, fuel filters, fuel level sender, fuel fill valve with OPD, bleeder valve (fixed liquid level gauge), supply circuit assembly with excess flow valve, return circuit assembly and a wiring harness.

There are four propane filters in the system. The primary filter is located in the fuel fill line which is intended to filter out the majority of contaminants that may be present in the fuel from the filling station. This filter must be replaced every 50,000 miles. The secondary fuel filter is a sock filter located inside the tank at the bottom (inlets) of the fuel pumps. The third and fourth filters are located after each fuel pump inside the tank, which are to ensure that no contaminants reach the fuel injectors. The in-tank filters are rated for the life of the vehicle.

ROUSH CleanTech LPA vehicles require HD-5 propane, rated for automotive use. Use of HD-10 or other substandard propane may result in excess contamination of the system and failure of the fuel pumps, injectors and in-tank filters.

Due to the inherent qualities of propane, a purge strategy must be employed during engine start up. Whenever the fuel pumps are not activated, there is a potential for the liquid propane in the fuel rails to absorb heat from the engine or from ambient temperatures. This heat may cause the fuel to expand rapidly and create vapor in the fuel rails. This vapor, if not purged from the fuel rails, can cause lean fueling or a no start condition.

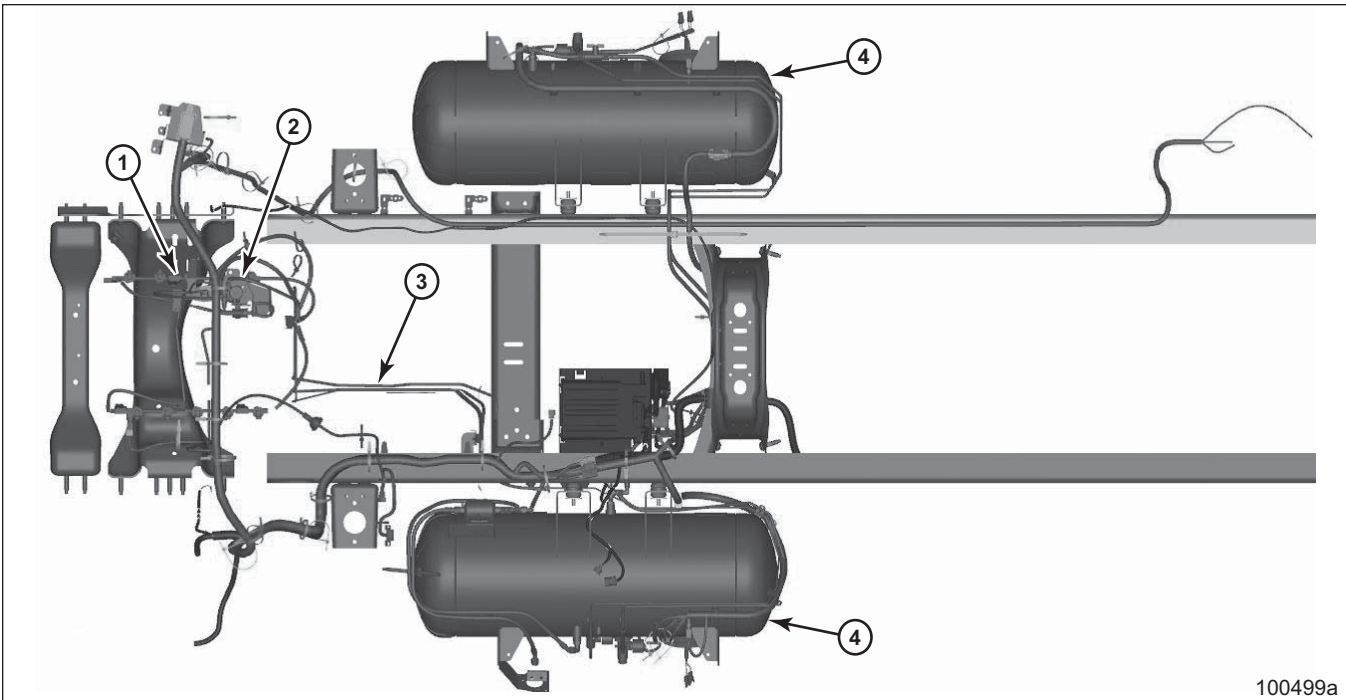

100499a

Figure 9 – F-650 Dual Tank Fuel System Overview

- 1. Fuel Rail and Injectors
- 2. FRPCM
- 3. Fuel Supply and Return Lines
- 4. Fuel Tank

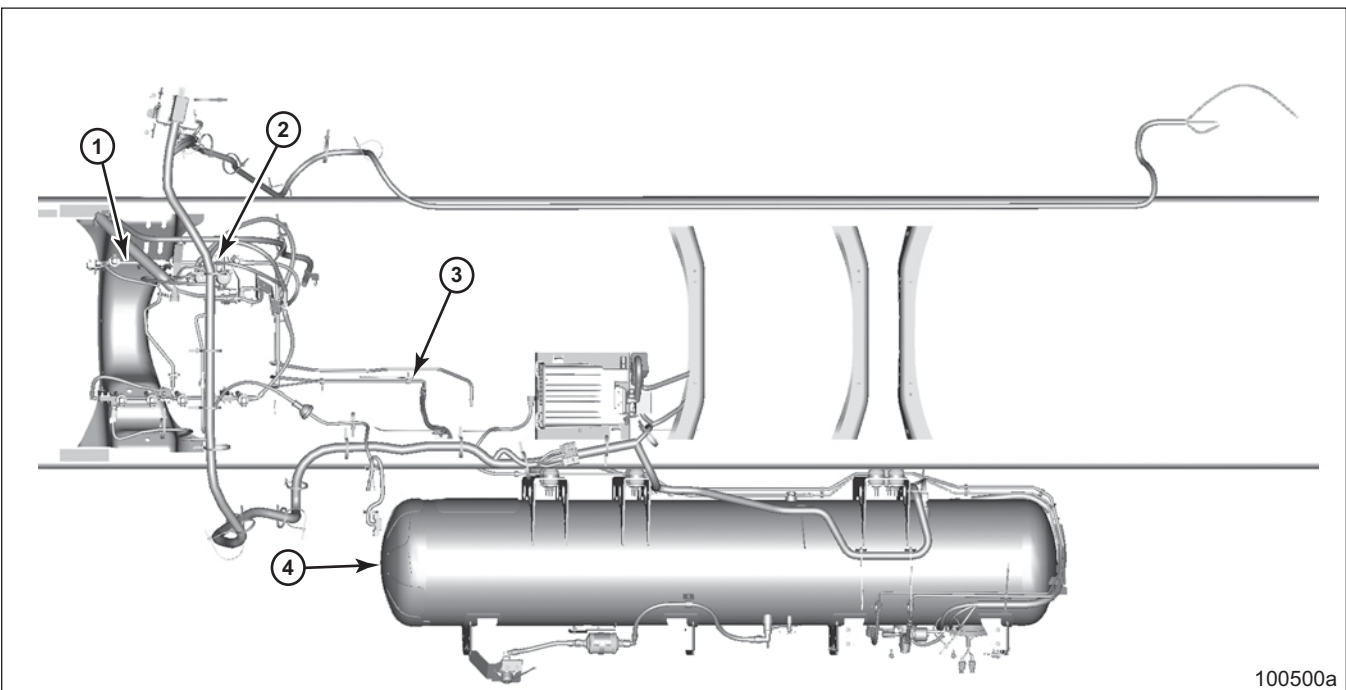

100500a

Figure 10 – F-650 Single Long Tank Fuel System Overview

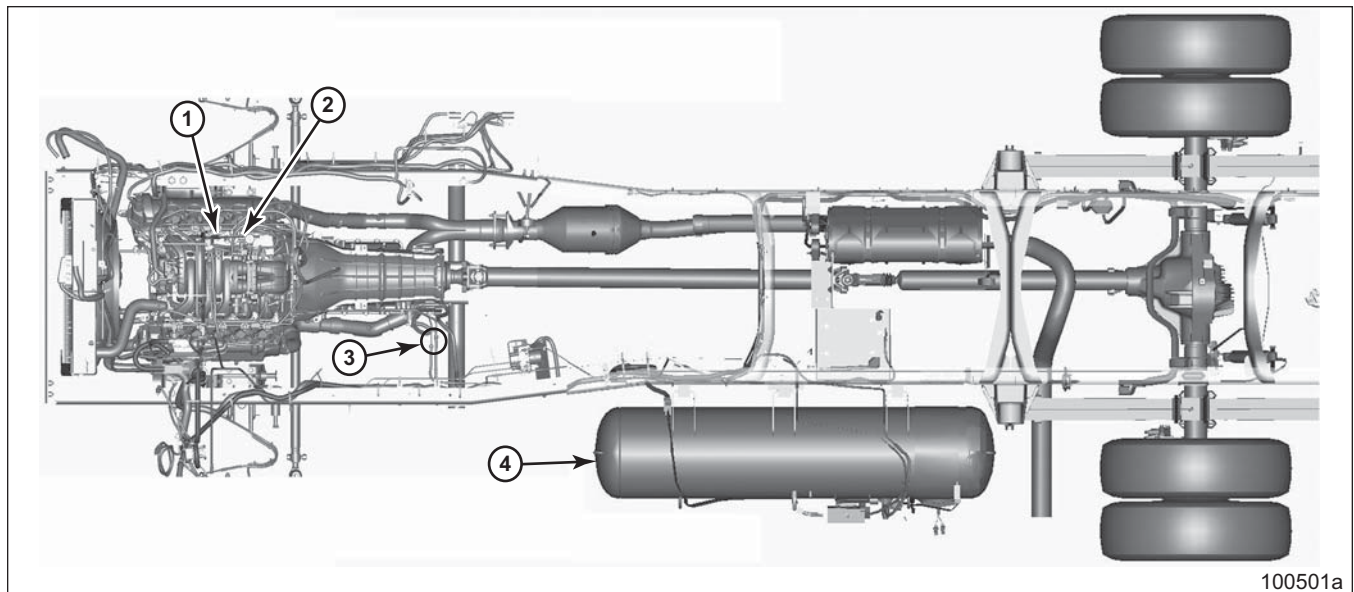

Figure 11 – F-59 Saddle Tank Fuel System

100501a

Start Sequence

When the engine is not running, the fuel in the rail boils and turns to vapor. For proper engine operation, the vapor must be flushed from the rail prior to starting the engine. This is a fully automated process that is controlled by the PCM. This process typically takes 7-15 seconds, but depending on ambient conditions, engine off time, and engine temperature at shutdown, it could take up to 43 seconds. The cycle will begin when the operator turns the key to the crank position and released to the ON position. Upon receiving the crank request, the PCM initiates the start sequence. During this time, the PCM performs diagnostics on several of the solenoids, as well as flushing the rail of vapor. This is accomplished by monitoring the injection pressure and temperature sensor (IPTS) while opening the various solenoids in the tank and FRPCM in stages, then engaging the fuel pump. Refer to *LPA Fuel System Components and Function* for a more detailed description of the components.

There are seven distinct stages of the start cycle:

Stage	Name	Description
1	CAN Bus Initialization	For the sequence to work, the PCM and Gateway module need to be communicating. There is a short delay after key-up to ensure communication has been established.
2	Bleed Diagnostic Pressure Read	The PCM measures the fuel pressure in the rail after a bleed cycle. All solenoids are still closed at this time. If the pressure is too high, the system did not bleed and a fault will set.
3	Open Tank Solenoid	The tank solenoid is energized. The pressure in the rail is measured (again). This pressure will be used later to determine if the FRPCM supply solenoid has properly opened.
4	Open Supply Solenoid	The FRPCM supply solenoid is energized.
5	Flush	The FCS is energized and the fuel pump is turned on high speed. The IPTS monitors pressure and temperature in the rail to determine when the vapor has been cleared from the rail.
6	Pressure Build	The FCS is de-energized and the pressure is allowed to rise. The IPTS is still monitoring the pressure and temperature in the rail to ensure there is liquid in the rail.
7	Crank	Once liquid is detected in the rail, the PCM engages the starter, and starts the vehicle.

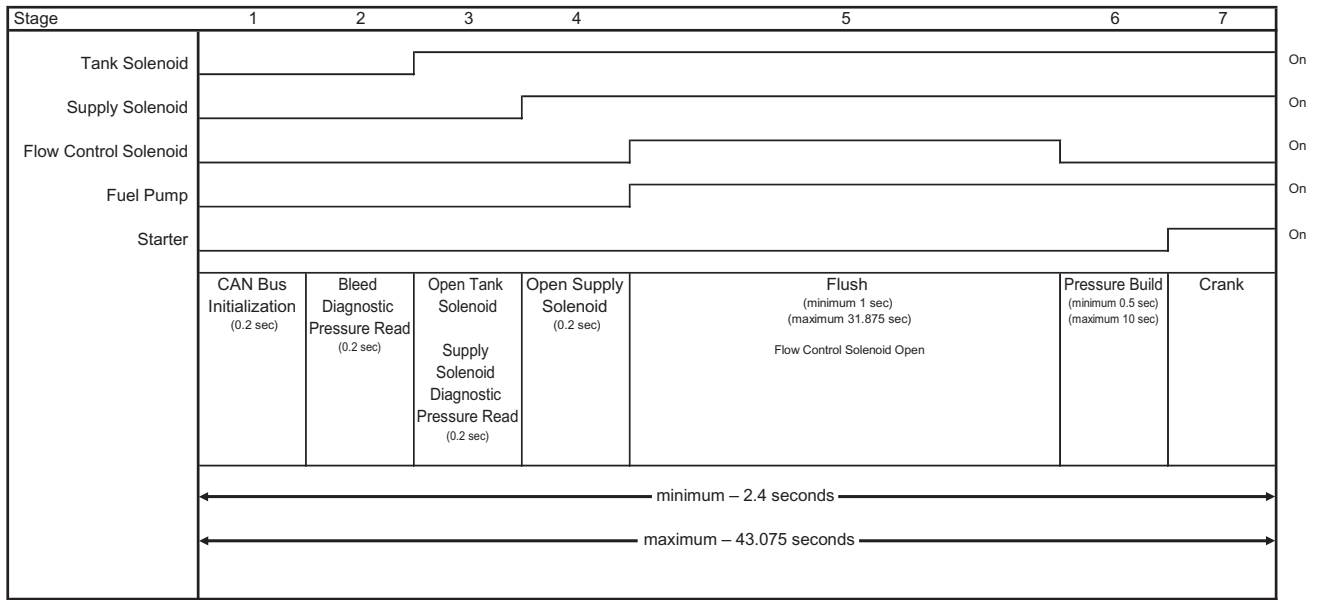

100120a

Figure 12 – Vehicle Start Sequence

General Propane Tank Filling Procedure

The most important aspect of filling a propane tank is safety. Understanding the properties and characteristics as well as the safe handling practices of the fuel is required before conducting any propane tank filling actions.

A propane-powered vehicle is equipped with a propane tank built and certified to the regulations of the American Society of Mechanical Engineers (ASME). These tanks have a data plate with pertinent information including the ASME stamp. This plate must be securely attached and legible or the tank should be taken out of service and replaced.

Propane tanks are filled to 80% capacity to allow for the liquid fuel to expand and contract depending on ambient temperatures. All tanks built for use on motor vehicles are equipped with an overfill protection device (OPD). The National Fire Protection Association (NFPA) requires motor vehicle propane tanks be equipped with an OPD to automatically prevent filling the tank beyond the maximum recommended capacity of 80%. This automatic stop fill system prevents overfilling of the fuel tanks. This requirement has been in effect since January 1, 1984.

Propane Powered Motor Vehicle Filling Overview

The fuel fill system includes the following components:

1. Fuel fill valve, cap and mounting bracket
 - The valve is located behind the fuel door.
2. Fuel fill hoses
3. Fuel fill filter and mounting clamp
4. Fuel tank mounted fill valve containing a mechanical OPD.
5. Fuel tank internal components

During a fill event, the system functions as follows:

1. Customer connects fuel dispensing nozzle to fill valve and activates the fill station pump.
2. Fuel pressure in the fill line causes the remote fill valve, tank fill valve and tank shutoff valve to open. In order for the valves to open, pressure in the fill line must be at least 20 psi higher than tank pressure, otherwise fill is not possible.
3. Once the fuel reaches the 80% fill level, the OPD closes the shutoff valve, not allowing additional fuel to flow into the tank.

NOTE

Some fuel station pumps may have sufficient pressure to allow a small fuel flow into the tank even with the valves closed. The operator should stop the fill as soon the fuel flow drops noticeably.

Vehicle Filling Procedure

This filling procedure is included for reference only. All personnel conducting fills should receive safety training on proper fill procedures.



For passenger safety, ROUSH CleanTech recommends that all occupants leave the vehicle to a safety zone before fuel filling procedures take place. Failure to heed this warning can result in personal injury.

1. Upon entering the propane fueling station, park the vehicle in close proximity to the motor fuel dispensing station.



No smoking or cell phone use allowed. Failure to heed this warning can result in personal injury.

2. Turn off and remove the vehicle ignition key.



Technicians working with, or around, fuel systems should be properly trained to utilize extreme care and caution at all times. Failure to exercise extreme caution and care may lead to serious accidents which can result in property damage, personal injury and/or death.

3. Exit the vehicle and ask all passengers to step outside the vehicle.
 - a. Some stations may ask all passengers to stand outside the area where the fill process is taking place.
 - b. Some stations could be self-service and the driver would perform the filling process; however in this case, the driver has to be trained and certified to obtain an authorized filling station dispenser access card.
4. The attendant may need to inspect the propane tank for corrosion, dents and verify the data plate displays the ASME stamp and other pertinent information is correct. An attendant can refuse to fill your propane tank if it does not pass this inspection. Regular inspection and maintenance of your tank will prevent refusal to fill the tank.
5. Open the fuel door.

6. Verify the dispenser meter is set to zero.
 - If the dispenser is an electronic dispenser, it will set to zero automatically once the transaction has been initiated.
7. Connect the fuel nozzle to the vehicle fueling receptacle.
 - The propane fueling nozzle must be screwed on securely (clockwise).
 - a. Wear protective gloves while fueling a propane tank.



Liquid propane is cold. The temperature of propane when leaked to atmosphere from its liquid state is -44°F (-42°C). Wear eye and ear protection during venting and repair operations. Keep moisture away from valves. Failure to heed this warning can result in personal injury.

- b. Remove the protective cap from the vehicle fueling receptacle.
- c. Mate the nozzle coupling to the fueling receptacle.
- d. Turn the nozzle coupling in a clockwise direction two or three turns until secure. A soft rubber washer or O-ring seals the connection so over tightening is not required to obtain a good seal.
- e. Most nozzles for motor vehicle fueling are much like a gasoline-type nozzle. The nozzles are also minimum-bleed type for safety and to meet hydrocarbon release requirements in certain jurisdictions.



It is not necessary or advised to open the remote bleeder valve (if equipped) or the bleeder valve on the tank while filling as this will allow gaseous propane to be released. Some stations require the valve to be opened; this should only be performed by qualified personnel.

8. Turn on the propane dispenser/pump and begin the filling process.
 - a. Pay attention and never walk away from the filling process.

- b. When the tank is full, the OPD automatically stops the filling process at the 80% liquid level capacity of the tank.
9. Release or close the fueling nozzle.
 - a. Turn off the fuel dispenser/pump.
 - b. Carefully and slowly unscrew the fueling nozzle (counterclockwise) to release any residual pressure and remove the nozzle from the vehicle.

NOTE

Some nozzles may have more pressure trapped between the nozzle and the receptacle, so it is necessary to slowly unscrew the connection to allow pressure to bleed off before removing the nozzle completely.

10. Replace the nozzle and fuel transfer hose on the dispenser.
11. Verify there are no leaks at the tank filling receptacle and replace the protective cap.
12. Close the fuel door.

! WARNING

During the propane vehicle fueling process, fuel may be emitted to the immediate area. There could be a combustible fuel mixture around this immediate area. The person performing the refueling process has total responsibility for safety in the immediate area.

NOTE

- It is unlawful to fill a non-compliant tank or a tank that possesses a safety violation.
- Any person performing the refueling must be trained and certified in filling propane tanks and for safe handling.

LPA FUEL SYSTEM COMPONENTS AND FUNCTION**Propane Fuel Tank**

The LPA system utilizes a cylindrical tank assembly to store the liquid propane. The fuel tank is designed and certified to meet all applicable safety standards required for installation on a motor vehicle. The tank design includes structural mounting brackets, which are used for mounting the tank assembly between the frame rails, in the cargo or bed area or behind the rear axle depending on vehicle application. The tank assembly is secured to the chassis using specially coated and grade-level fasteners.

In addition, the tank is fitted with a pressure relief valve (PRV) that will open if tank pressure exceeds 312 or 375 psi (2151 or 2585 kPa). The excess pressure (propane vapor) is vented off and the structural integrity of the tank is protected.

The following components are mounted to the outside of the fuel tank: bleeder valve (fixed liquid level gauge), supply circuit assembly, return circuit assembly, pressure relief valve, fill port and check valve with OPD and fuel level sender.

The fuel tank is fitted with a service port flange for accessing the internals of the tank. The following components are located inside the fuel tank: dual electric fuel pumps with an inlet filter, fuel pump outlet filters, jet pump and a wiring harness.

! WARNING

Make sure to reinstall the tank with the original fasteners or new like fasteners when servicing the tank or removing the tank from the vehicle. Do not replace the fasteners with a lower grade than originally equipped as this may cause the tank to become dislodged from the vehicle and cause serious damage or personal injury.

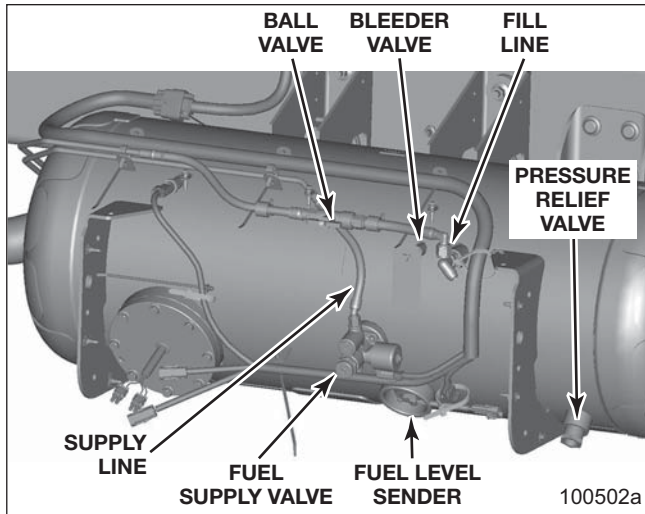

Figure 13 – F-650 RH Dual Tank

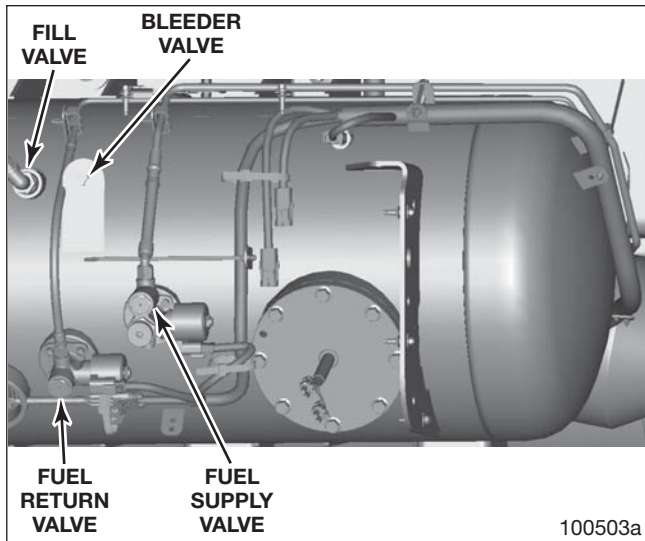

Figure 14 – F-650 LH Dual Tank Front View

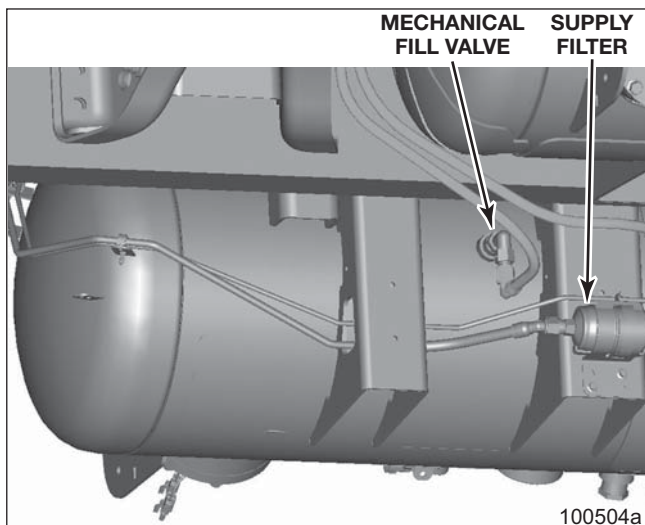

Figure 15 – F-650 LH Dual Tank Rear View

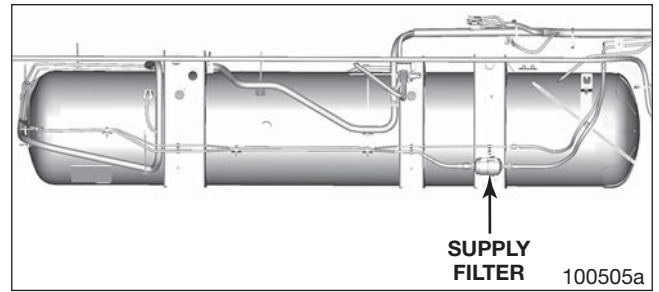

Figure 16 – F-650 Single Long Tank Rear View

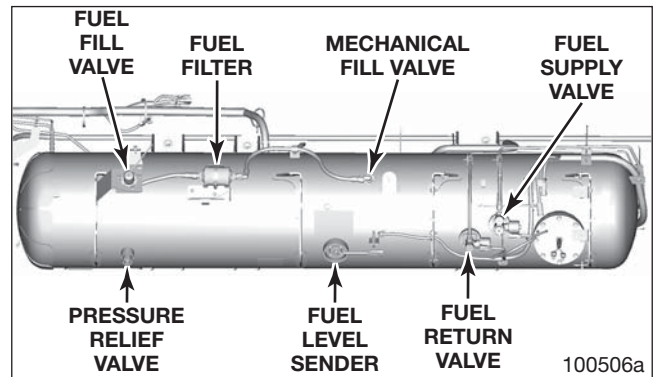

Figure 17 – F-650 Single Long Tank Front View

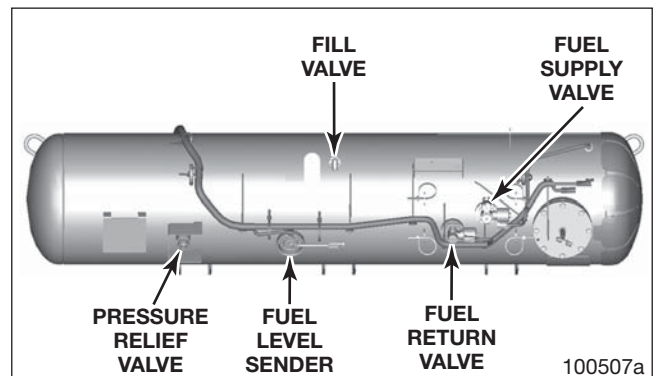

Figure 18 – F-59 Saddle Tank

Tank Fill Valve/Overfill Protection Device

Located where fuel enters into the fuel tank, the fill valve is opened mechanically by the refueling pump pressure during the fill process. It incorporates a backflow check valve and the OPD. The backflow check valve closes when tank pressure is greater than pressure outside of the tank to prevent fuel from escaping.

Fuel Pumps

The LPA fuel system utilizes two 12-volt in-tank fuel pumps. The fuel pump assembly is mounted to brackets located in the bottom of the fuel tank. The pumps are serviceable through the service port opening on the bottom of the fuel tank.

The in-tank pumps receive a 12-volt supply when the ignition key is switched on and runs a purge cycle for up to 30 seconds. Each pump is controlled by an EFPR, which is controlled by the PCM. The pump is provided with a constant ground signal. During operation the pump voltage will vary from 7-13.5V.

Tank Pressure Temperature Sensor

There is a tank pressure temperature sensor or (TPTS) mounted on the fuel tank assembly that reads both fuel tank pressure and fuel tank temperature and supplies these values to the Ford PCM via the Gateway module. This sensor is utilized to help target an expected fuel rail pressure to the engine to ensure the propane in the fuel rails remains in a liquid form at all times during operation.



Figure 19 – Tank Pressure Temperature Sensor

Fuel Level Sender

The tank is fitted with a fuel level sender that consists of an in-tank float arm coupled to an externally mounted variable voltage sensor. This sender provides a fuel level signal to the instrument panel, which utilizes an “anti-slosh” signal conditioner to provide a constant gauge reading. The fuel level sender is serviceable from the top of the tank through a service opening in the floor of the bus and includes a visual indicator which can be referenced during service.

NOTE

The fuel level indicator on the sender will vary slightly from actual fuel level.



Figure 20 – Fuel Level Sender

Tank Bleeder Valve/Fixed Liquid Level Gauge

The bleeder valve/fixed liquid level gauge serves two functions:

1. Offers a means to evacuate the tank for tank internal component service procedures.
2. Allows annual verification of the function on the OPD.

NOTE

The tank bleeder valve is to remain open during vehicle operation.



Figure 21 – Tank Bleeder Valve/Fixed Liquid Level Gauge

Pressure Relief Valve

The pressure relief valve will activate when tank pressure is above 312 or 375 psi (2151 or 2585 kPa). Propane vapor will vent through the pressure relief hose until tank pressure is between 281-309 psig. Propane vapor is vented out of the pressure relief hose and exits the vehicle vent mounted to the body on the street side behind the rear axle. This is a safety feature designed to prevent excessive tank pressure.

Tank Supply Circuit Assembly

The fuel supply circuit consists of an excess flow valve, tank solenoid (automatic shut off valve) and a manual shutoff valve. The supply circuit tank solenoid is controlled by the PCM and is activated whenever power is supplied to the fuel pump.



Figure 22 – Fuel Tank Supply Circuit

Tank Solenoid Valve

The tank solenoid is an electrically operated automatic shutoff valve. It is located downstream from the excess flow valve and manual shutoff valve. The tank solenoid is normally in a closed position (de-energized), preventing the flow of fuel to the engine. When the ignition key is turned on to start the vehicle, power is supplied to the solenoid opening the valve and allowing fuel to flow from the tank to the engine. The tank solenoid will close when the ignition is shut off, or if the engine stalls (with ignition on).

Manual Shutoff Valve

The manual shutoff valve is used to seal the outlet of the tank during shipping, service or in case of a vehicle failure. It is located between the excess flow valve and tank solenoid valve. It is manually operated by turning the knurled knob mounted on the front of the supply circuit assembly. Turning the knob clockwise closes the valve and turning the knob counterclockwise opens the valve. It should always be open when the vehicle is operating.

Excess Flow Valve (XFV)

The excess flow valve is located in the supply fuel path, ahead of the tank solenoid and manual shutoff valve. The valve is intended to shut off fuel flow from the tank in the event of a rapid pressure drop outside the fuel tank. A rapid pressure drop could be caused by a severed line or an inadvertent disconnect without shutting the manual shutoff valve. If the excess flow valve trips (may happen after servicing the system), it can be reset by closing the manual shutoff valve and then slowly opening it. The excess flow valve does not completely stop flow and will not actuate with smaller leaks, so it should not be relied on for servicing purposes. If the excess flow valve activates (such as immediately following service where the system may not be primed with fuel), turn off the key and wait 15-30 seconds then retry.

Fuel Return Circuit Assembly

The fuel return valve on the tank incorporates a check valve, which prevents fuel from flowing from the tank into the return line. The fuel return valve also contains the flow control solenoid (FCS) which includes a small orifice to restrict return flow in normal conditions; and a bypass circuit to allow maximum fuel flow prior to engine starting or during extremely hot conditions.



Figure 23 – Fuel Return Circuit Assembly

Fuel Lines

The fuel transfer lines utilized in the LPA fuel system are made of a steel-reinforced PTFE with stainless steel hard line sections to provide long term protection and service. The 3/8” supply and 1/4” return lines contain ORB style fittings or compression style fittings. The use of line wrenches is recommended for removal and installation.

NOTE

When replacing hoses and lines, use ROUSH CleanTech replacement parts made from the same material and size. Always route and secure hoses as originally installed. All hoses and lines must be compliant and labeled per NFPA 58 requirements.



Figure 24 – Flexible Fuel Line

Fuel Rail Pressure Control Module (FRPCM)

The FRPCM is a unit consisting of two normally closed solenoids and a return check valve. The FRPCM is controlled directly by the Gateway module which is governed by the PCM. Included in the FRPCM are:

Supply Solenoid — Open (energized) when the engine is running, the supply solenoid allows fuel to flow from the chassis fuel lines to the fuel rail. The supply solenoid is closed when the engine is turned off, preventing fuel from flowing from the chassis fuel lines to the engine fuel rail.

NOTE

There is a second supply solenoid located at the fuel tank which prevents fuel from flowing into the chassis fuel lines when the engine is turned off.

Bleed Solenoid — Closed when the engine is running, the bleed solenoid seals the fuel rail from the vehicle EVAP system. When ambient temperature is above 40°F, after the engine is turned off for approximately one hour, the bleed solenoid opens for a calibrated length of time allowing all the fuel pressure to bleed from the fuel rail through a metered orifice and into the carbon canister. When the process is complete, the solenoid closes, preventing fuel from entering the EVAP system.



Figure 25 – Fuel Rail Pressure Control Module (FRPCM)

Injection Pressure Temperature Sensor

The injection pressure temperature sensor is located in the driver side fuel rail and is used to determine the pressure and temperature of the propane in the fuel rail. This information is supplied to the Ford PCM via the Gateway module and helps to ensure the propane in the fuel rails is kept in a liquid form as well as assisting with fuel injector pulse width.

Vapor Canister Assembly

A vapor canister is being utilized to vent the fuel vapors remaining in the fuel rail during engine shut-off to eliminate the chance of propane leaking past the fuel injectors.

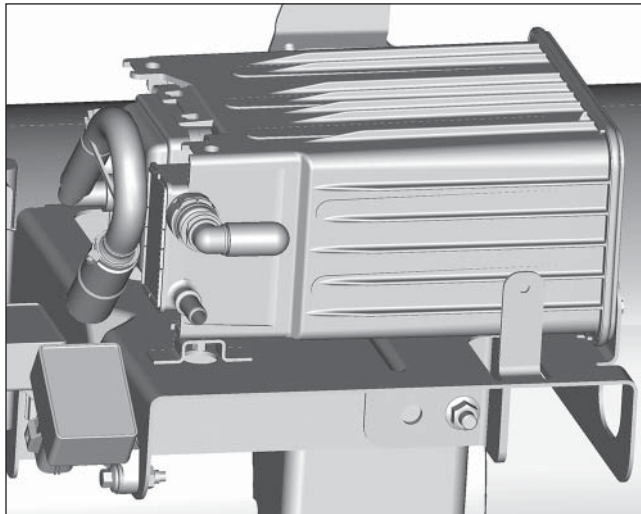

Figure 26 – Vapor Canister and Line Assembly

Vapor Lines

The fuel vapor hoses are flexible with quick connect fittings, which can be easily disconnected by pinching the connector release points.

Fuel Rail Assemblies

Each fuel rail assembly is mounted to the intake manifold by three brackets, and is made up of the following components:

- Five fuel injectors retained in the fuel rail by a C-clip. The injectors are connected to the main engine wiring harness. Fuel metering and injection is controlled by the engine PCM as the injectors are opened and closed by switching the ground internally in the PCM.
- Five injector spacers sealed to the fuel rail and intake manifold injector ports by O-rings and retained to the fuel rail with a retention clip.

- A fuel pressure and temperature sensor (FPTS) is mounted on the left hand rail.

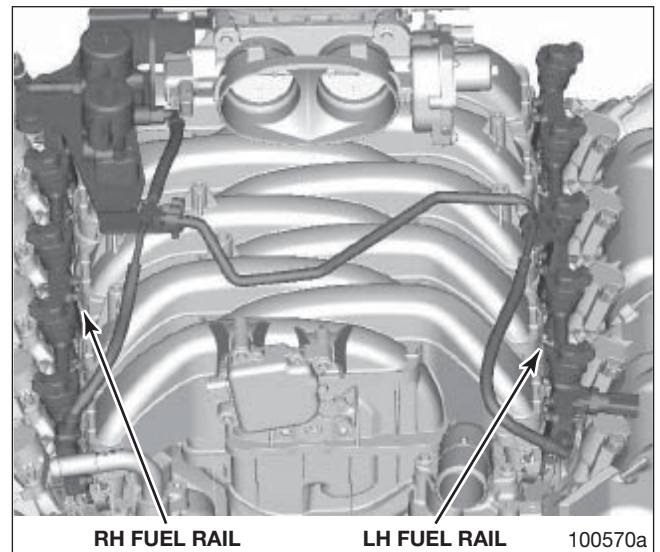

Figure 27 – Fuel Rails

Remote Fill Valve

This valve is used to connect the refueling station nozzle to the fill line during filling. It is mounted to a bracket behind the locked fuel door on the curb side of the bus and has a screw-on protective dust cap. It contains a backflow check valve to prevent propane in the line from escaping when the dispensing nozzle is removed.

Fill Line

The fill line is a flexible black line with non-serviceable fittings on either end, connecting between the remote fill valve, in-line fill filter and the tank fill valve.

Fuel Fill Filter

The fuel fill filter is mounted in various locations depending on application. In some applications, the fuel filter is mounted to the fuel tank. Other locations are on the left frame rail or on the rear crossmember or on a bracket behind the tank cover plate. The filter is always between the fuel fill valve and the tank fill valve. The filter consists of an internal filtering cartridge capable of filtering out contaminants as small as 5 microns. The filter should be replaced every 50,000 miles.

Electronic Fuel Pump Relay (EFPR)

The relay controls the fuel pump voltage, which controls the fuel pump duty cycle. Each fuel pump is controlled by a separate EFPR. The EFPRs are mounted to a bracket on the frame cross member in front of the fuel tank.

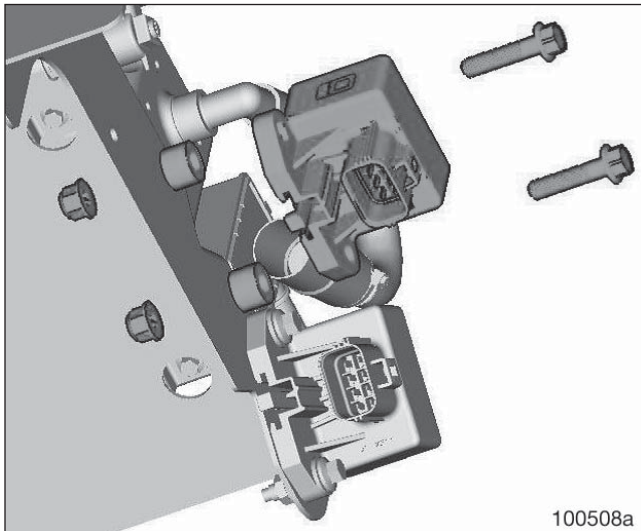

Figure 28 – Electronic Fuel Pump Relays

Smart Relay Module/LPA Gateway Module

The Gateway module is an electronic control module that provides two functions within the LPA system:

1. Communications Gateway between the electrical system and the engine/transmission controller.
2. To provide additional input/output features required for the LPA fuel system.

LPA Interface Function

The Gateway module controls the following functions within the LPA system:

- Fuel rail pressure control module solenoids
- Fuel tank supply solenoid

The Gateway module supplies the following information to the Ford engine controller:

- Fuel rail temperature and pressure
- Fuel tank temperature and pressure
- Second fuel pump relay module fault status
- Fuel level
- A/C signal input from secondary A/C system

NOTE

Signals supplied to the Ford engine controller will be diagnosed by the engine controller and reported as engine P-codes. Lack of communication between the Gateway module and the engine controller will also be reported by the engine controller.

GLOSSARY

Bleed Solenoid — Closed when the engine is running, sealing the fuel rail from the evaporative system. After the engine is turned off for approximately one hour, the bleed solenoid opens for a calibrated length of time allowing pressure to bleed from the fuel rails. The bleed solenoid is part of the FRPCM.

Excess Flow Valve — The XFV is located in the supply fuel path, ahead of the tank solenoid and manual shutoff valve. The valve is intended to shut off fuel flow from the fuel tank in the event of a rapid pressure drop outside the tank. It is part of the tank supply circuit assembly.

Fill Valve — Serves as the fuel fill inlet to the fuel tank for attachment of the fill station hose. The valve is a one-way single-back check valve that opens during the fuel fill process and closes when fueling is complete to minimize fuel from escaping.

Flow Control Solenoid (Tank Return Circuit Assembly) — Closed when the engine is running, the FCS directs fuel to flow through a metered orifice back to the fuel tank. The solenoid is open prior to cranking the engine to cool the fuel rail and remove any vapor from the rail. The solenoid is opened for approximately 15 seconds after the engine is turned off to allow pressure in the fuel rails to return to the fuel tank. The solenoid may also be opened to flush the fuel rails to make sure that there is liquid fuel in the fuel rails during hot operating conditions. The solenoid is part of the tank return circuit assembly and also contains an XFV as with the tank supply circuit assembly.

Fuel Fill Filter — In-line between the fill valve and the fuel tank to filter fuel before entering the fuel tank during the fill process.

DESCRIPTION AND OPERATION

Fuel Level Sending — The tank is fitted with a fuel level sender that consists of an in-tank float arm coupled to an externally mounted variable voltage sensor. This sender provides a fuel level signal to the instrument panel, which utilizes an “anti-slosh” signal conditioner to provide a constant gauge reading. The fuel level sender is serviceable from the top of the tank through a service opening in the floor of the vehicle and includes a visual indicator which can be referenced during service.

NOTE

The fuel level indicator on the sender will vary slightly from actual fuel level.

Fuel Rail Pressure Control Module — The fuel rail pressure control module (FRPCM) consists of two solenoids (supply valve B and bleed) and a vapor port controlled by a separate electronic control module. The FRPCM is mounted on the engine.

Fuel Supply Valve — Opened electrically by the flow control solenoid to provide fuel to the engine. Also incorporates an XfV to minimize fuel escaping if there is a large leak in the fuel supply line external to the tank.

Fuel Tank Fill Valve — Located where fuel enters into the fuel tank. During the fill process, the valve is opened by the fuel fill pressure. The valve also is incorporated with double-back redundant check valves that close when fuel tank pressure is greater than the pressure outside of the tank to prevent fuel from escaping.

Integrated Pressure Temperature Sensor — The integrated pressure temperature sensor (IPTS) is mounted on the left fuel rail and is used to monitor pressure and temperature of the fuel.

Manual Shutoff Valve — Manually operated valve that is used to seal the outlet of the fuel tank during shipping or service. The valve should always be open when the vehicle is operating. The valve is part of the tank supply circuit assembly.

Overfill Protection Device — The overfill protection device (OPD) is part of the fuel tank fill valve, a lever-actuated valve that shuts off filling when the fuel in the tank is at the 80% level. The lever is actuated by a float mechanism that is raised by the fuel.

Pressure Relief Valve — Automatically opens to relieve excessive pressure inside of the fuel tank.

Smart Relay Module — The smart relay module (SRM) controls the actuation of the three solenoid valves in the FRPCM. The SRM receives the signal from the fuel level sending unit and broadcasts the signal to the PCM and the instrument cluster. The SRM also reads the IPTS and sends the information to the PCM via the CAN bus.

Supply Solenoid “B” — A solenoid that is open (energized) when the engine is running, allowing fuel to flow from the fuel lines to the fuel rails. The solenoid is closed when the engine is turned off, preventing fuel from flowing from the fuel tank to the fuel rails. The solenoid is part of the FRPCM.

Supply Solenoid “A” (Tank Supply Circuit Assembly) — Mounted directly on the fuel tank and serves as the main interface between the tank and engine. The assembly consists of the fuel tank solenoid, the XfV and the manual shutoff valve.

MAINTENANCE REQUIREMENTS

Refer to the ROUSH CleanTech Supplemental Owner's Guide for recommended service intervals and required maintenance.

Intake Air Assembly

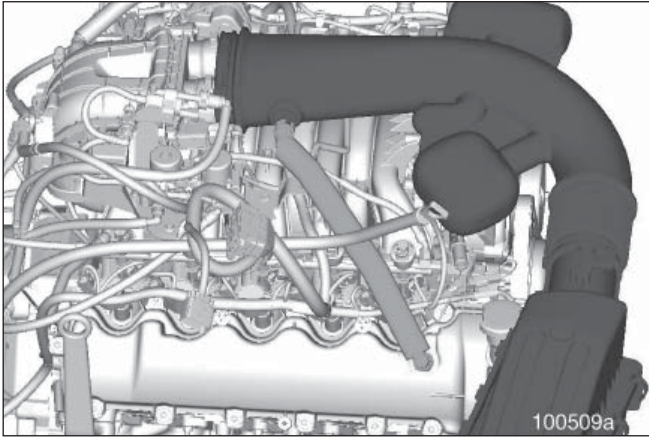

Figure 29 – Intake Air Assembly

The intake air assembly is common to base Ford vehicles. Consult the appropriate Ford Work Shop Manual for service.

In-Line Fuel Filter Replacement

⚠ DANGER

A trace amount of propane fuel will be released on loosening the fittings. It will settle to the lowest available surface before it dissipates into the atmosphere. Keep heat, sparks, flames, static electricity or other sources of ignition out of the area when venting or purging the fuel lines or tank.

Failure to heed this danger can result in severe personal injury or property damage.

1. Purge residual fuel from the fuel fill line by loosening the line fitting.
2. Disconnect the fuel fill line from the fuel filter inlet.

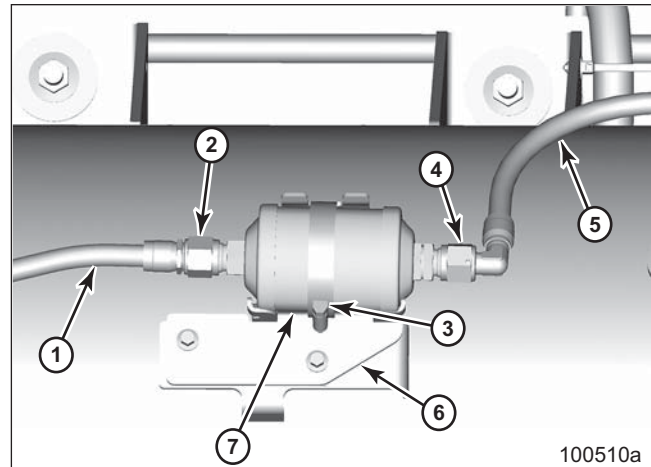

Figure 30 – In-Line Fuel Filter (Typical)

1. Fuel Fill Line (Fill Valve-to-Filter)	5. Fuel Fill Line (Filter-to-Tank)
2. Inlet Line Nut	6. Fuel Fill Bracket
3. Filter Retention Clamp	7. Fuel Filter
4. Outlet Line Nut	

3. Disconnect the fuel fill line from the fuel filter outlet.
4. Loosen the clamp retaining the fuel filter to the bracket.
5. Remove and discard the filter.
6. Place a new fuel filter in position on the filter bracket and tighten the retaining clamp to 4-5 Nm.
7. Connect the fuel fill lines to the filter inlet and outlet. Tighten the line fittings at the tank and fill valve to 41-49 Nm. Tighten the line fittings on the filter to 53-61 Nm.

PREPARING VEHICLE FOR SERVICE

Alert Messages

The following alert messages appear from time to time in appropriate places in this manual. Ensure that all personnel in the immediate area are aware of these messages. These messages consist of Dangers, Warnings and Cautions. Other messages may appear as Notes.

Propane is nontoxic, nonpoisonous, has the lowest flammability range of any alternative fuel and dissipates quickly when released into the atmosphere. When the ratio of propane to air is between 2.2% and 9.6%, propane burns in the presence of an ignition source at 940°F (504°C).

⚠ DANGER

Gasoline auto-ignition occurs at a much lower temperature: 430-500°F (221-260°C) or hotter. Keep away from heat, sparks, flames, static electricity and other sources of ignition. Failure to heed this danger can result in severe personal injury.

⚠ DANGER

Fuel supply lines remain pressurized after engine shutdown. Keep away from heat, sparks, flames, static electricity or other sources of ignition. Do NOT enter storage areas or confined spaces unless they are adequately ventilated. Failure to heed this danger can result in severe personal injury or death.

⚠ DANGER

Propane is heavier than air and seeks the lowest available level when released to the atmosphere. Keep heat, sparks, flames, static electricity or other sources of ignition out of the area when venting or purging the fuel lines or tank. Failure to heed this danger can result in severe personal injury or property damage.

⚠ WARNING

Liquid propane is cold. The temperature of propane in its liquid state is -44°F (-42°C). Wear eye and ear protection during venting and repair operations. Keep moisture away from the valves. Failure to heed this warning can result in personal injury.

NOTE

Identify the condition (good, stuck open, stuck closed or inoperable) of each solenoid valve prior to venting the fuel tank to ensure that the solenoid valves are not the reason for vehicle service and unnecessarily venting the tank.

Manual Fuel Shutoff

NOTE

This procedure ensures that no propane leaves the fuel tank during service activities.

1. Remove the manual shutoff valve access plug on the tank cover plate.

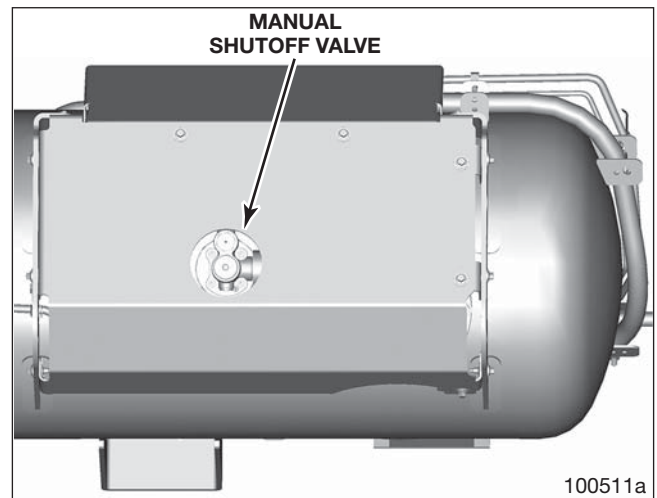

Figure 31 – Manual Shutoff Valve

2. Turn the knurled knob of the manual shutoff valve clockwise until it stops and is fully closed. The propane supply from the tank is now mechanically shut off.

NOTE

The manual shutoff valve can be hard to turn. From fully open to fully closed is approximately 3-1/2 turns.

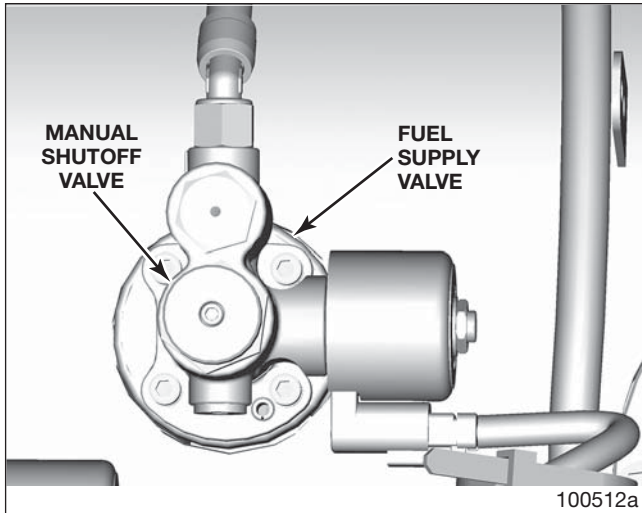

Figure 32 – Manual Shutoff Valve (Typical)

- When finished with the service or repair, open the manual shutoff valve.

Tank Cover Plate

NOTE

To access fuel system components, remove the tank cover plate as necessary.

- Remove the bolts and washers and remove the tank cover plate.

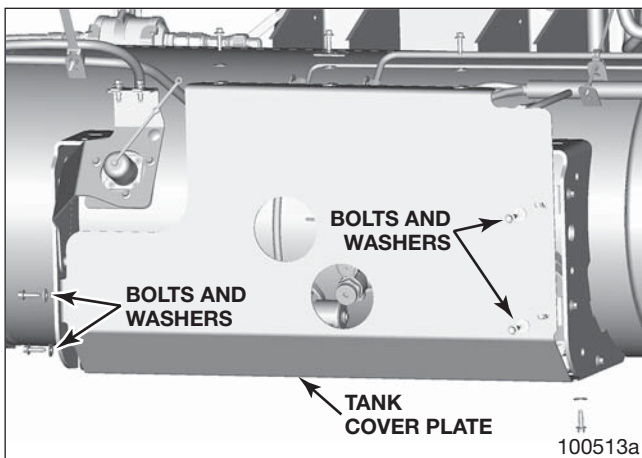

Figure 33 – F-650 LH Dual Tank Cover Plate

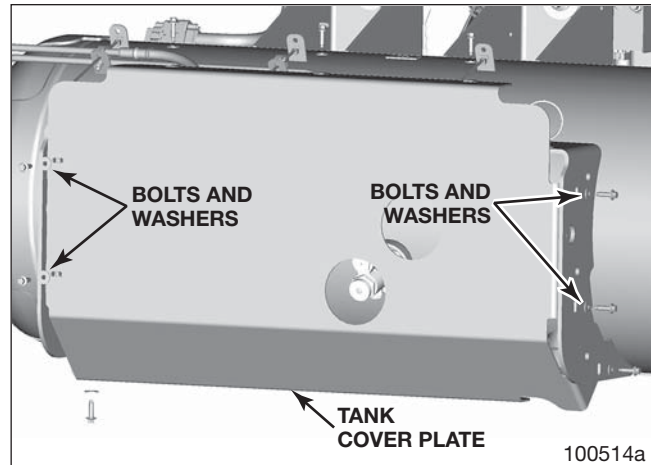

Figure 34 – F-650 RH Dual Cover Plate

- To install, reverse the removal procedure. Tighten fasteners to specification. Refer to *Specifications* for more information.

Fuel Line Purging and Fuel Tank Draining Procedures

During any fuel system maintenance or repair in which the fuel pressure must be released from the system or the system completely evacuated, use the following procedures.

⚠ DANGER

Technicians working with, or around, fuel systems should be properly trained to utilize extreme care and caution at all times. Failure to exercise extreme caution and care may lead to serious accidents which can result in property damage, personal injury and/or death.

⚠ WARNING

LPG is under pressure, wear adequate eye protection. When LPG is discharged into the atmosphere, the rapid change in pressure can cause a refrigerant condition in the fuel (quick cooling) and can harm your skin or cause serious burns much like frostbite. Always wear appropriate protective gloves. Failure to heed this warning can result in serious personal injury.

REPAIR PROCEDURES

! WARNING

Propane is heavier than air and seeks the lowest available level when released to the atmosphere. Keep heat, sparks, flames, static electricity or other sources of ignition out of the area when venting or purging the fuel lines or tank. Failure to heed this warning can result in severe personal injury or property damage.

! WARNING

When releasing the fuel pressure, be sure to place the discharge point of the drain hose in a safe area free from any combustible material or ignition source. Be sure that no one is in the immediate area of the discharge hose. Failure to heed this warning can result in severe personal injury.

! WARNING

Liquid propane is cold. The temperature of propane in its liquid state at atmospheric pressure is -44°F (-42°C). Wear eye and ear protection during venting and repair operations. Keep moisture away from the valves. Failure to heed this warning can result in personal injury.

FUEL LINE PURGING

Clearing the propane out of the fuel lines (purging) is required before working on many fuel system components. Following the suggested techniques for purging the fuel lines will reduce the amount of vapor released harmlessly into the atmosphere and will produce the least risk to life and property.

1. Close the manual shutoff valve on the tank supply valve. Refer to *Manual Fuel Shutoff* for more information.
2. Remove the Ford fuel pump fuse. This disconnects the power to the fuel pumps.

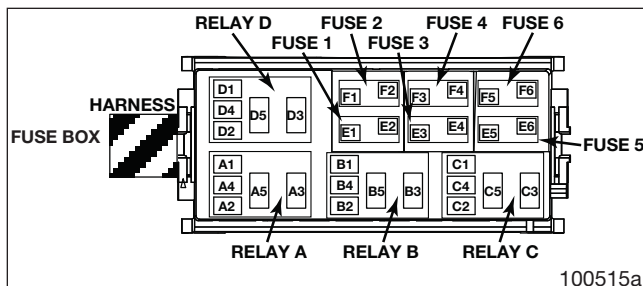

Figure 35 – Fuse Box

3. Start the engine and let it run until it stalls. This purges the fuel supply line of liquid propane.
4. Energize all of the fuel rail pressure control module (FRPCM) solenoids for 20 minutes.
5. Measure fuel pressure to ensure that the fuel rails are purged of propane (less than 25 psi).
6. Disconnect the negative battery cable from the battery.
7. Relieve pressure in the fuel return line by slowly loosening the quick-connect fitting in the return line under the vehicle.

! WARNING

Liquid propane is cold. The temperature of propane in its liquid state is -44°F (-42°C). Wear eye and ear protection during venting and repair operations. Keep moisture away from the valves. Failure to heed this warning can result in severe personal injury.

8. Connect the fuel return line quick-connect fitting.

! WARNING

When releasing the fuel pressure, be sure to keep the discharge point of the line in a safe area free from any combustible material or ignition source. Be sure that no one is in the immediate area of the fuel line. Failure to heed this warning can result in severe personal injury.

NOTE

There may still be a small amount of propane in the lines after completing this procedure. Open the lines slowly and cautiously to bleed off any remaining propane.

FUEL TANK DRAINING

! DANGER

Technicians working with, or around, fuel systems should be properly trained to utilize extreme care and caution at all times. Failure to exercise extreme care and caution may lead to serious accidents which can result in property damage, personal injury or death.

⚠ DANGER

Propane is nontoxic, nonpoisonous, has the lowest flammability range of any alternative fuel and dissipates quickly when released into the atmosphere. Propane vapor is heavier than air and seeks the lowest point. When the ratio of propane to air is between 2.2% and 9.6%, propane burns in the presence of an ignition source at 940°F (504°C) or hotter. Keep away from heat, sparks, flames, static electricity and other sources of ignition. Failure to heed this danger can result in severe personal injury or death.

The fuel tank on an LPA fuel system utilizes two electric fuel pumps to deliver fuel to the fuel injectors during normal operation. If you are shipping the tank, servicing one of the valves or to service in-tank components, you must follow the procedures listed.

⚠ DANGER

Draining the LPA tank should be performed by a trained technician only. When draining a fuel tank, use all the following precautions to prevent serious personal injury, death or property damage.

⚠ DANGER

Propane is heavier than air and seeks the lowest available level when released to the atmosphere. Keep heat, sparks, flames, static electricity or other sources of ignition out of the area when venting or purging the fuel lines or tank. Failure to heed this danger can result in severe personal injury or property damage.

⚠ WARNING

Liquid propane is cold. The temperature of propane in its liquid state is -44°F (-42°C). Wear eye and ear protection during venting and repair operations. Keep moisture away from the valves. Failure to heed this warning can result in personal injury.

- Wear protective eye wear, gloves and clothing.
- Perform the process in a well-ventilated area only.
- Remove all potential ignition sources from the area.

- Use only the recommended processes.
- Use the proper tools.
- Drain the tank on the vehicle into a tank of equivalent or larger capacity.

Using In-Tank Pumps

Use of the in-tank pumps to drain the tank is an acceptable method assuming at least one of the two pumps and the supply valve are functioning normally. Temperature can affect transfer rates.

NOTE

This method will not completely drain the tank and a final process of venting the tank will still be required. In some areas it is not allowed or may not be safe to vent the fuel to the atmosphere. In this case, the fuel must be burned off.

1. Move the vehicle to a well-ventilated area free of any external ignition sources.
2. Place the tank in which the fuel is to be captured close to the tank to be drained.
3. Purge the fuel lines by using the *Fuel Line Purging Procedure*.
4. Disconnect supply line from forward side of in-line filter at front of fuel tank.
5. Connect the fuel transfer hose to the receiving tank fill valve or other appropriate valve.
6. Connect the transfer hose to the forward side of filter that line was removed from in Step 4.
7. Disconnect the fuel pump wire harness in vehicle and connect a switch to the fuel pump wire connectors.
8. Open the manual supply valve on the tank to be drained.
9. Open the automatic supply valve on the tank to be drained, this requires 12V power to the supply solenoid.
10. Turn the switch on the jumper harness to the ON position, you should hear the pumps in the fuel tank running and fuel will begin to transfer to the capture fuel tank.
11. When the liquid propane level in the fuel tank drops below the fuel pump's pickup tube, the pump will make a different sound. Turn the switch off to stop the pump.

REPAIR PROCEDURES

NOTE

Running fuel pumps without liquid in them will cause damage to the pumps and lead to premature failure.

12. The remaining fuel in the tank will now need to be evacuated through the bleed valve.
13. Manually close the supply valve on the vehicle tank.
14. Loosen the fuel transfer hose and bleed off the fuel pressure.

WARNING

Fuel may be under pressure in the transfer line; use caution when disconnecting the fittings, slowly loosen the fittings and use gloves and protective eye wear.

15. Disconnect the transfer hose from the receiving tank and place the other end of the transfer hose in a safe, well ventilated location away from any area where the fuel could create a volatile condition.
16. Slowly open the manual supply valve and allow the tank to vent until the pressure has been released completely from the tank. If the excess flow closes during this operation, simply close the supply valve and re-open it slowly.

NOTE

The tank can be evacuated using a flare stand, if the service center is equipped with a stand and has received the proper training.

17. If using a flare stand to burn off the remaining fuel in the tank this would require approximately a 50-foot clearance from the vehicle, other vehicles, a building or any combustible materials. Slowly open the valve on the flare stand and light the escaping gas; open the valve little by little to decrease the time to evacuate.

CAUTION

Some states and municipalities may have regulations preventing the release of LPG into the atmosphere. Check with your local fire marshal or your local LPG supplier prior to venting or burning off a tank.

18. When the pressure in the tank has reduced to a point that it does not support the flame turn the liquid supply valve off and disconnect the hoses. Open the remote bleeder valve to vent the remaining pressure to the atmosphere.

WARNING

Do not have any sources of ignition within a minimum of 50 foot of the area.

19. Once the tank has vented, close the supply valve and bleeder valves on the tank.

NOTE

If you have any questions or concerns or you feel unqualified to perform the process of venting the tank, contact your local fuel system provider or ROUSH CleanTech (800) 59-ROUSH.

FUEL SYSTEM COMPONENT SERVICE

Fuel Tank

WARNING

Care must be taken while working with liquid propane. All steps must be followed to prevent personal injury and component damage.

NOTE

Locate a suitable place to put the fuel tank so that it can be worked on after being removed from the vehicle. The tank might also require temporary storage in preparation for shipment.

NOTE

Tank attachment points will vary by configuration.

1. Remove the tank cover plate. Refer to *Tank Cover Plate* for more information.
2. Purge the propane from the fuel lines and drain the fuel tank. Refer to *Fuel Line Purging and Fuel Tank Draining Procedure* for more information.

3. Purge the residual fuel from the fuel lines by loosening one of the fittings.
4. Disconnect the fuel fill line fitting from the fill valve and cut the tie strap of the edge clip.
5. If necessary, route the fuel fill line through the tank mounting bracket and over the frame rail so that the line is free.
6. Disconnect the fuel supply line and fuel return lines. Disconnect the transfer line on dual tank configurations. Cut any tie straps from the tank jumper harness as needed. Make sure all lines and harness are free so that the fuel tank can be removed.

⚠ WARNING

Take care when using lifting devices during service and maintenance procedures to avoid serious personal injury and damage to components. Inspect all lifting straps to make sure they are not damaged. Do not subject lifting straps to shocks or droploding.

7. Obtain a hoist capable of safely lifting 1,000 lb (373 kg). Attach the hoist to the fuel tank using lifting straps and chains. Support the tank while removing the tank mounting fasteners.
8. At each mounting point, remove the nuts, bolts, steel washers and black washers attaching the tank to the tank mounting brackets. Remove the rubber isolators and crush limiters as necessary.

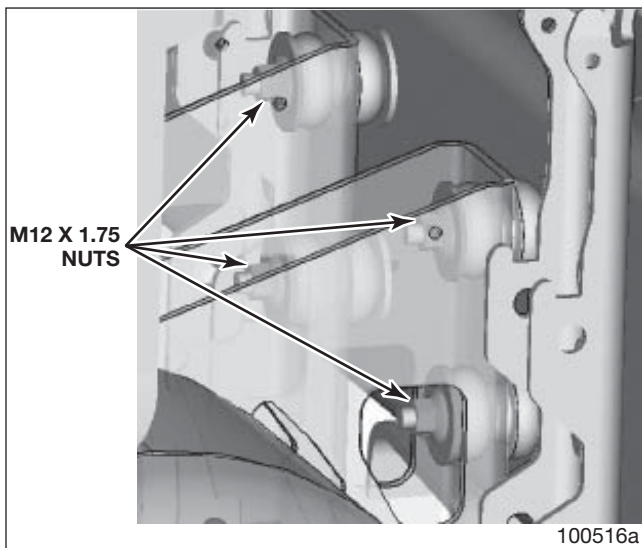

Figure 36 – Mounting Nuts

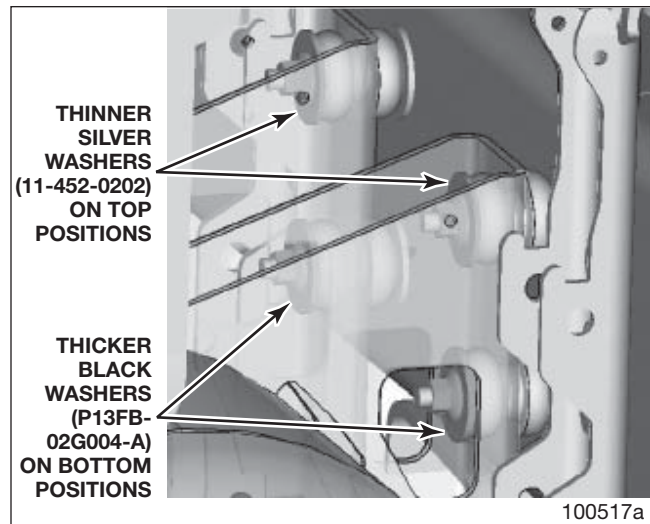

Figure 37 – Mounting Washers

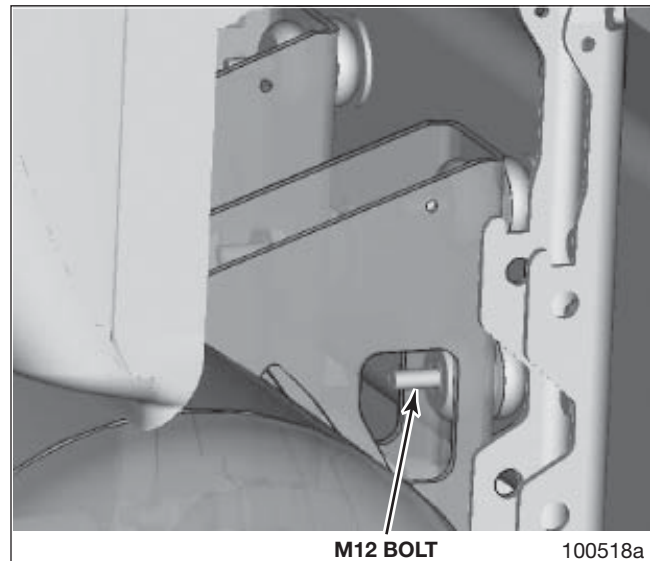

Figure 38 – Mounting Bolt

9. With the help of an assistant, slowly lower the tank and remove it from the vehicle. Make sure the tank, along with the fuel lines, fill line and electrical harness, are clear of any obstructions.
10. Place the tank on a safe work bench to perform tank service or other component service as necessary. Support the tank brackets on blocks so that the tank can be worked on from underneath.

NOTE

If replacing the fuel tank, the fuel lines, fill lines, electrical harnesses and fuel filter (and bracket) must be removed and transferred to the replacement tank. Refer to the appropriate *Repair Procedures* for more information.

11. Detach the hoist and remove the lifting straps.
12. Remove the washers.

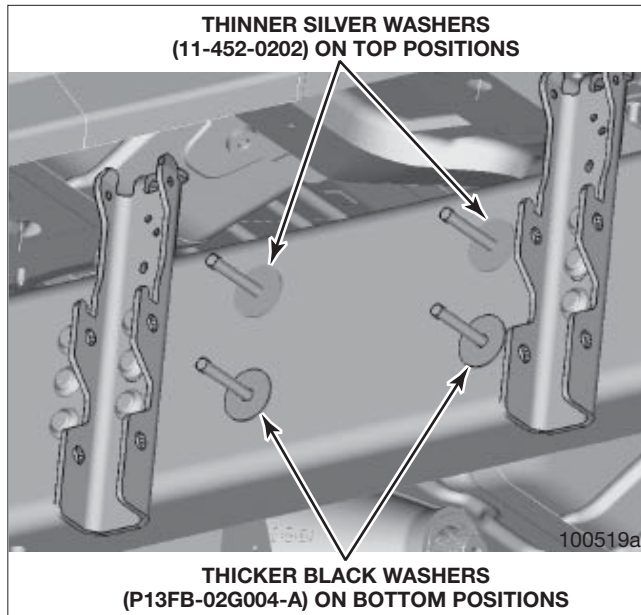

Figure 39 – Mounting Washers at Frame

13. Remove the M12 X 1.75 bolts from the doubler plates. Note the orientation of the doubler plates so the bolts can be reinstalled in the same position.

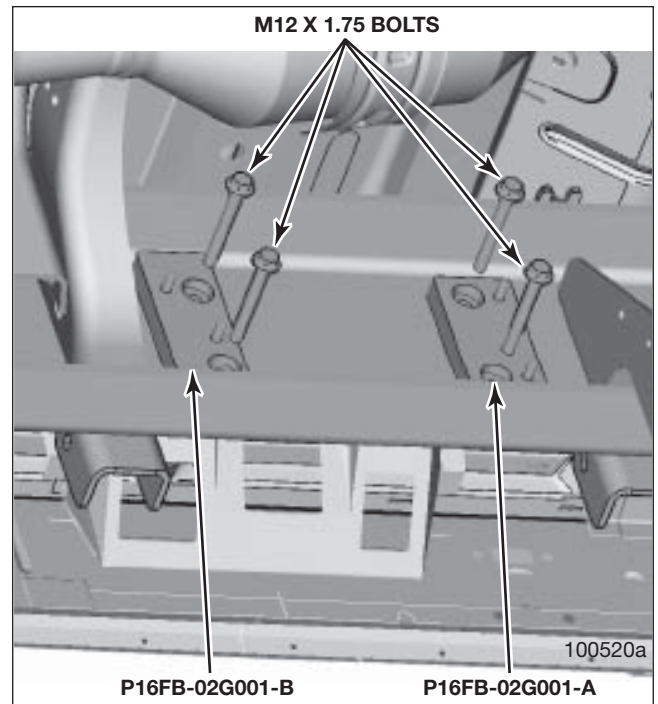

Figure 40 – Doubler Plates

14. Remove the rubber isolators and crush limiters as necessary.

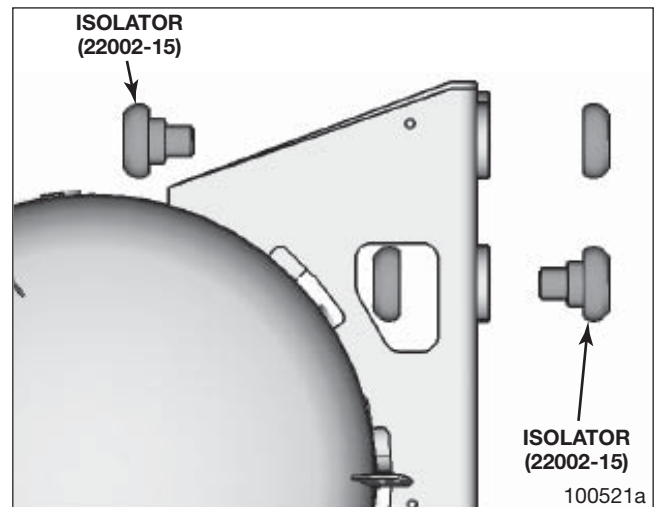

Figure 41 – Isolators and Crush Limiters

15. To install the fuel tank, reverse the removal procedure. Make all electrical connections and use new tie straps to secure components. Tighten all nuts, bolts, fittings and connections to specification. Refer to *Specifications* for more information.

NOTE

After all fuel system components have been installed and tightened to specification, the system must be bled, filled with propane and checked for leaks. Refer to *Preparing Vehicle for Use After Service*.

Fuel Tank Pressure Relief Valve

CAUTION

Be sure the tank has been completely drained before removing the pressure relief valve from the tank.

Removal

1. Purge the fuel lines using the *Fuel Line Purging Procedure*.
2. Drain the fuel tank using the *Fuel Tank Draining Procedure*.
3. Slowly remove the pressure relief valve from tank using caution as there still may be some residual pressure in the tank.

Replacement

1. Install the new pressure relief valve (thread sealant pre-applied) into the threaded coupling, torque to 120 Nm minimum plus 180 degrees.
2. Purge the fuel lines using the *Fuel Line Purging Procedure*.
3. Reconnect the battery.
4. Perform the *Fuel System Priming Procedure*.

Tank Supply Valve Assembly

Located on the bottom of the LH tank cylinder behind the supply circuit cover.

CAUTION

Be sure the tank has been completely drained before removing any of the supply valve components from the tank.

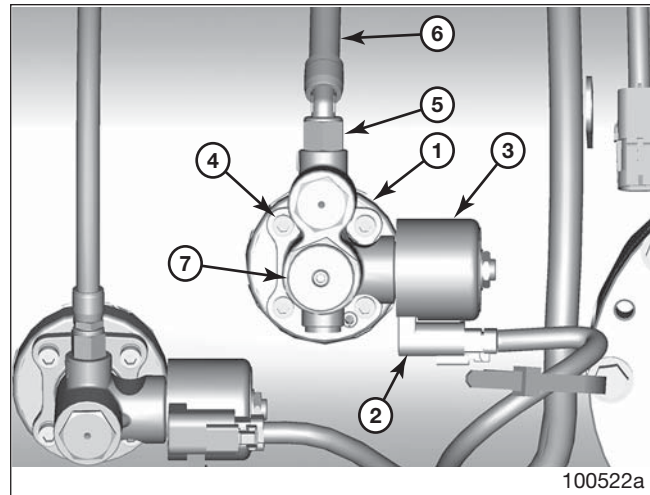

Figure 42 – Supply Circuit Assembly

1. Fuel Supply Valve	5. Fitting
2. Solenoid Electrical Connection	6. Fuel Supply Line
3. Supply Valve Solenoid	7. Manual Shutoff Valve
4. Supply Valve Bolt (4)	

Removal

1. Purge the fuel lines using the *Fuel Line Purging Procedure*.
2. Drain the fuel tank using the *Fuel Tank Draining Procedure*.

CAUTION

Ensure the battery ground wires are disconnected before proceeding.

3. Disconnect the chassis flex line from the supply line on the tank using the appropriate disconnect tool.
4. Remove the supply line bolt from the front tank support.
5. Remove the supply line at the valve using the appropriate disconnect tool.
6. Disconnect the supply solenoid electrical connection.
7. Slowly loosen each bolt a small amount until the valve is loose and it is confirmed that no pressure is present in the tank.
8. Pull the supply circuit assembly away from the tank.
9. Disconnect the internal fuel pump supply line by depressing the colored tabs on either side of the quick connect fitting and pulling it off the stem.

NOTE

Retain the fuel supply line with a clip to prevent it from slipping back into the fuel tank.

10. Remove and discard the O-ring from the bottom of the supply valve.

Replacement

NOTE

When replacing the supply circuit assembly, the tank seat O-ring must be replaced.

1. Inspect the O-ring sealing surface and remove any debris.
2. Apply silicone O-ring lubricant (Parker Super Lube or equivalent) to the O-ring and install to the supply solenoid.
3. Lubricate the tip of the brass stem quick connect with a small amount of motor oil.
4. Connect the internal fuel pump supply line, push on until a “click” is heard, then tug to insure it is secured.
5. Slide the supply valve assembly to the tank seat.
6. While holding the supply circuit valve assembly, install the four bolts and hand tighten.
7. Torque the bolts using the sequence and torques shown in Figure 43.
 - a. Initial Torque: Crossing pattern
2.5 +/-0.5 Nm
 - b. Final Torque: Crossing pattern 10 +/-1 Nm
8. Install the threaded fitting of the supply line to the supply valve, torque to 29 to 33 Nm.
9. Close the remote bleeder valve.
10. Connect the wiring harness to the tank solenoid coil.
11. Secure the supply line to the front mounting bracket on the tank.
12. Connect the chassis flex line to the tank supply line.
13. Purge the fuel tank using the *Fuel Tank Purging Procedure*.
14. Connect the vehicle battery.
15. Fill the tank with 10 gallons of propane.
16. Check the supply valve and tank lines for leaks using an electronic leak detector or leak detection solution.

17. Reinstall the supply circuit cover and hand tighten the thumb screws.

18. Perform the *Fuel System Priming Procedure*.

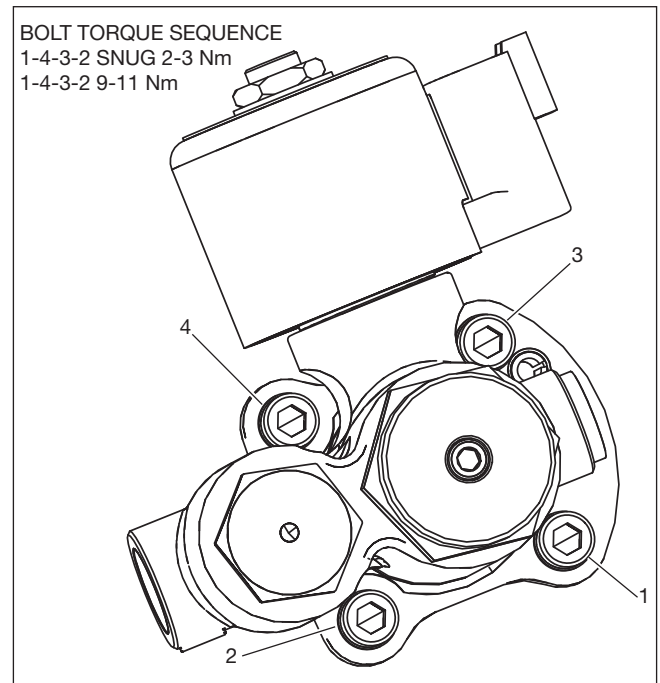

Figure 43 – Supply Circuit Torque Sequence

Fuel Tank Return Valve

Located on the bottom of the LH tank cylinder behind the supply circuit cover.



Be sure the tank has been completely drained before removing the return line or valve from the tank.

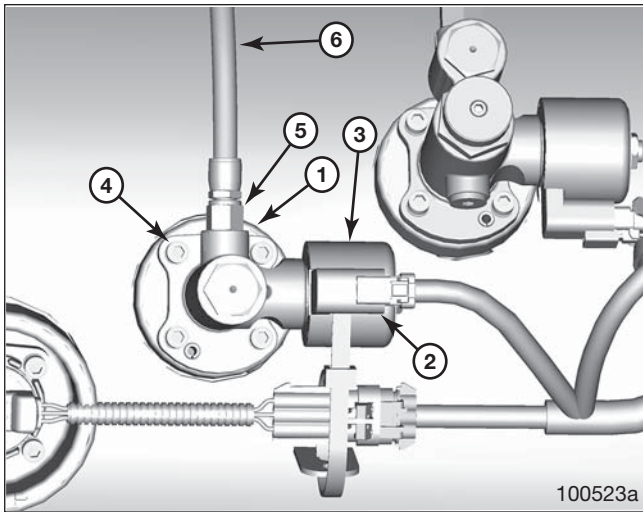

Figure 44 – Tank Return Circuit Assembly

1. Fuel Return Valve	4. Return Valve Bolt (4)
2. Solenoid Electrical Connection	5. Fitting
3. Return Valve Solenoid	6. Fuel Return Line

Removal

1. Purge the fuel lines using the *Fuel Line Purging Procedure*.
2. Drain the fuel tank using the *Fuel Tank Draining Procedure*.
3. Disconnect the chassis flex fuel line from the hard lines on the tank
4. Remove the supply and return line bolts from the front tank support
5. Remove the fuel supply and return lines from the valves.
6. Slowly loosen the bolts one at a time until the valve is loose and it is confirmed that no pressure is present in tank.
7. Remove the return hose from the return valve quick connect fitting.

NOTE

Retain the fuel return line with a clip to prevent it from slipping back into the fuel tank.

Replacement

1. Slide the return valve assembly to the tank seat.
2. While holding the return valve assembly, install the four bolts and hand tighten.

3. Torque the bolts using the sequence and torques shown in Figure 43.
 - a. Initial Torque: Crossing pattern 2.5 +/-0.5 Nm.
 - b. Final Torque: Crossing pattern 10 +/-1 Nm.
4. Install the threaded fitting of the return line to the return valve, torque to 29 to 33 Nm.
5. Secure the fuel return line to the front tank support.
6. Lubricate the end of the fuel tank hard lines with oil and connect to the chassis flex lines and tug on them gently to confirm they are secure.
7. Purge the fuel tank using the *Fuel Tank Purging Procedure*.
8. Check line connections for leaks using an electronic leak detector or leak detection solution.
9. Reinstall the supply circuit cover apply anti-seize and hand tighten the thumb screws.
10. Connect vehicle batteries.
11. Perform the *Fuel System Priming Procedure*.

Tank Bleeder Valve

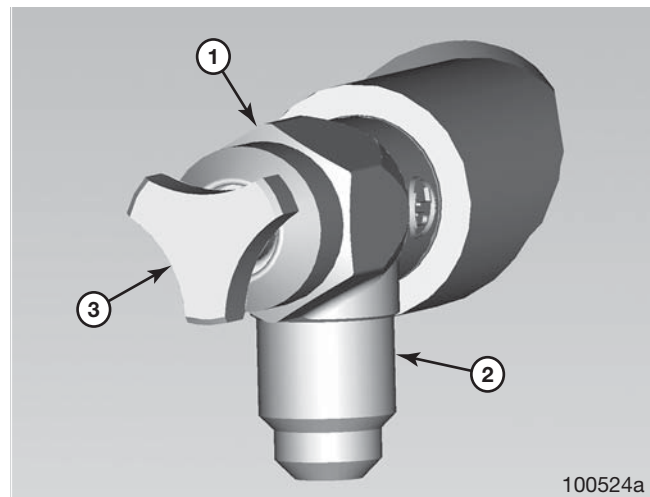

Figure 45 – Tank Bleeder Valve

1. Bleeder Valve	3. Bleeder Valve Knob
2. Tighten to this Orientation	

CAUTION

Be sure the tank has been completely drained before removing the fill valve from the tank.

Removal

1. Purge the fuel lines using the *Fuel Line Purge Procedure*.
2. Drain the fuel tank using the *Fuel Tank Draining Procedure*.
3. Remove the bleeder line from the tank bleeder valve.
4. Slowly remove the bleeder valve using caution as there may still be residual pressure in the tank.

Replacement

1. Apply pipe thread sealant (PLS-2 or Everseal 183) ONLY to the threads going into the tank.
2. Install the new bleeder valve assembly into the tank. Torque to 20 +/-4.0 Nm minimum, plus orientation, reverse torque not permissible (see Figure 45).
3. Reinstall the bleeder line to the valve and torque to 18.5 +/-3.0 Nm.
4. Purge the fuel tank using the *Fuel Tank Purging Procedure*.
5. Reconnect the battery.
6. Fill the tank and leak check the fitting using an electronic leak detector or an approved leak detection solution.

Fuel Pump Assembly (In-Tank)

Removal

1. Purge the fuel lines using the *Fuel Line Purge Procedure*.
2. Drain the fuel tank using the *Fuel Tank Draining Procedure*.

CAUTION

Ensure the battery ground wires are disconnected before proceeding.

3. Slowly remove the tank service cover from tank, loosening bolts in a star-pattern a small amount each time until the cover is loose. This will ensure no pressure is present.

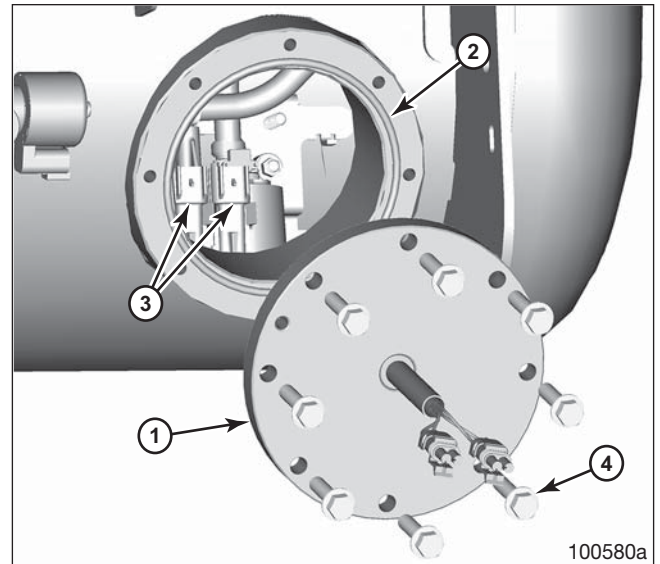

Figure 46 – Fuel Tank Service Cover (Typical)

1. Fuel Tank Service Cover	3. Fuel Pump Electrical Connectors
2. Service Cover O-ring	4. Service Cover Bolt (8)

4. Reach into the fuel tank and disconnect the fuel pump electrical connectors.
5. Release the pump hose quick connects from the in-tank filters.
6. Remove the center bolt and the two nuts that secure the pump housing to the tank bracket.
7. Remove the pump assembly from the fuel tank.

NOTE

Pumps are to be serviced as an assembly.

Replacement

1. Attach the new pump assembly to the tank bracket using the center bolt (5.8 +/-0.3 Nm) and two nuts (8.5 +/-0.5 Nm).
2. Attach the pump hose quick connects to the in-tank filters.
3. Connect the fuel pump electrical connectors.
4. Lubricate the tank supply cover O-ring with a small amount of motor oil and install it to the tank.

NOTE

Replacing the service cover O-ring whenever the cover is removed is recommended.

5. Install the tank service cover on the tank with the eight (8) cover bolts. Torque the bolts in the star pattern shown in Figure 47 as follows.

Step 1 — Tighten bolts 1-4 to 2-3 Nm
 Step 2 — Tighten bolts 1-4 to 38.6-42.6 Nm
 Step 3 — Tighten bolts 5-8 to 38.6-42.6 Nm

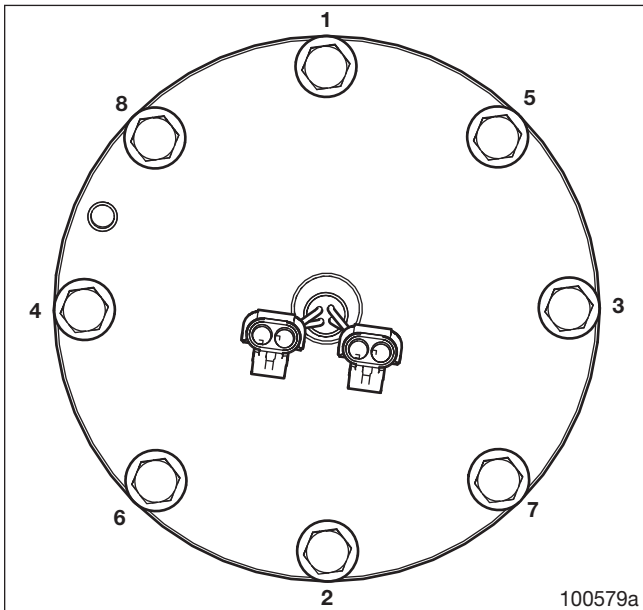

Figure 47 – Fuel Tank Service Cover Tightening (Typical)

6. Purge the fuel tank using the *Fuel Tank Purging Procedure*.
7. Reconnect the battery.
8. Check the supply valve and tank lines for leaks using an electronic leak detector or leak detection solution.
9. Reinstall the supply circuit cover and hand tighten the thumb screws.
10. Perform the *Fuel System Priming Procedure*.

Fuel Level Sender

Removal

1. Purge the fuel lines using the *Fuel Line Purge Procedure*.
2. Drain the fuel tank using the *Fuel Tank Draining Procedure*.

CAUTION

Ensure the battery ground wires are disconnected before proceeding.

3. Identify the location of the sending unit and remove any covers to access the sending unit for removal.
4. Disconnect the wiring connector to the fuel level sender.
5. Open the tank bleeder valve.
6. Slowly loosen each of the four fasteners a small amount each time until the sending unit assembly is loose to ensure no pressure is present in the tank.
7. Slide the level sender out of the tank.

Replacement

1. Install the new fuel level sender into the tank aligning it properly, see Figure 48. Apply silicone lubricant to the O-ring on the sender.
2. Secure the level sender to the tank with four bolts hand tight.
3. Torque the bolts using the sequence shown in Figure 49.
 - a. Initial Torque: Crossing pattern 2.5 +/-0.5 Nm
 - b. Final Torque: Crossing pattern 10 +/-1 Nm
4. Connect the wiring to the fuel level sender.
5. Close the tank bleeder valve.

NOTE

Since the tank was opened to replace the level sender, perform the *Fuel Tank Purging Procedure*.

6. Reconnect the vehicle batteries.
7. Leak check all fuel line joints with an electronic leak detector or leak detection solution.
8. Perform the *Fuel System Priming Procedure*.

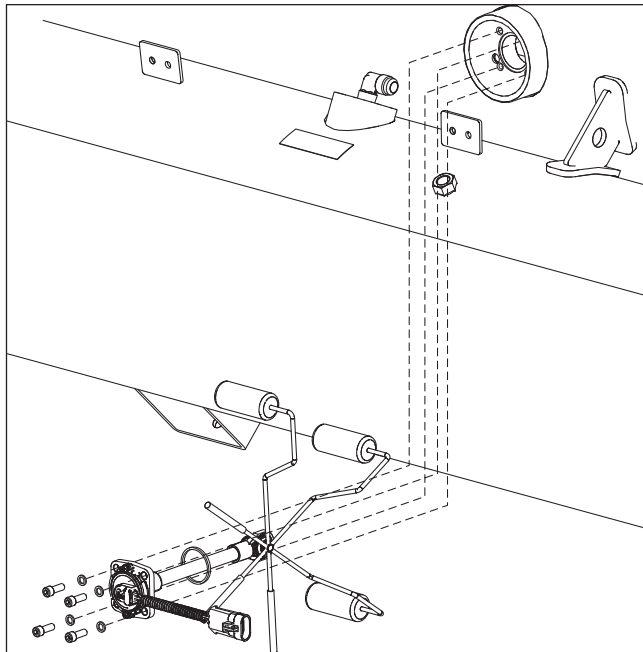

Figure 48 – Fuel Level Sender Installation

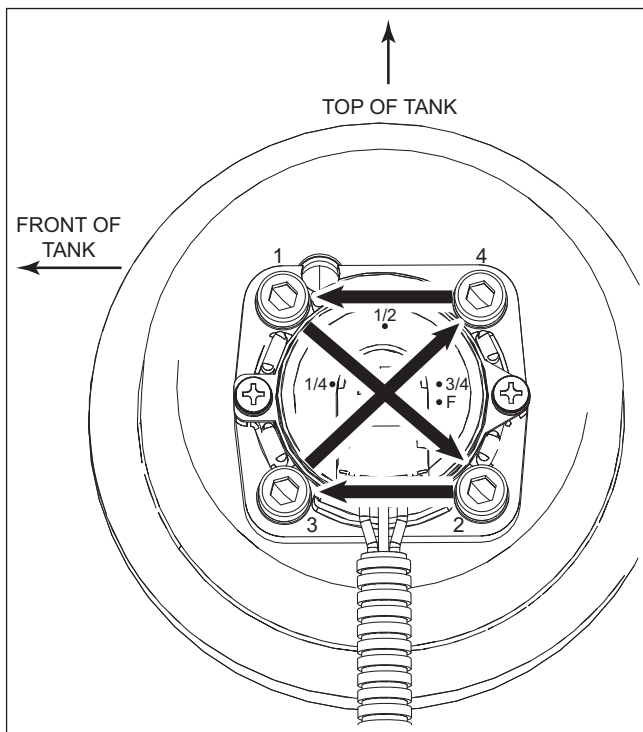

Figure 49 – Fuel Level Sender Torque Sequence

Fuel Tank Wiring

Two wiring harnesses are used on the fuel tank assembly; the fuel tank jumper harness and the tank solenoid/sender harness. The tank harness connects the following components from the fuel tank to the frame harness:

- Fuel pumps through the tank service flange
- Tank supply solenoid “A”
- Tank return circuit assembly “flow control solenoid” (drivers tank only)
- Fuel level sending unit

The tank harness connects to the frame harness at the inboard frame side of the tank near the top rear of the tank for dual tank systems and on the frame inboard side for single tanks.

Mechanical Fill Valve/Overfill Protection Device



A trace amount of propane fuel is released when loosening the fittings. Propane settles to the lowest available surface before dissipating into the atmosphere. Keep heat, sparks, flames, static electricity or other sources of ignition out of the area when venting or purging the fuel lines or tank. Failure to heed this danger can result in severe personal injury or property damage.

Removal



Make sure the tank has been completely drained before removing any fuel tank components. Failure to heed this warning can result in serious personal injury or damage to components.

1. Purge the propane from the fuel lines and tank. Refer to the *Fuel Line Purging and Fuel Tank Draining Procedures* for more information.
2. Remove the negative battery cable from the battery.
3. Remove the fuel fill line from the mechanical fill valve 90-degree elbow.

NOTE

Note the orientation of the elbow so that it can be installed in the same direction. Applications vary.

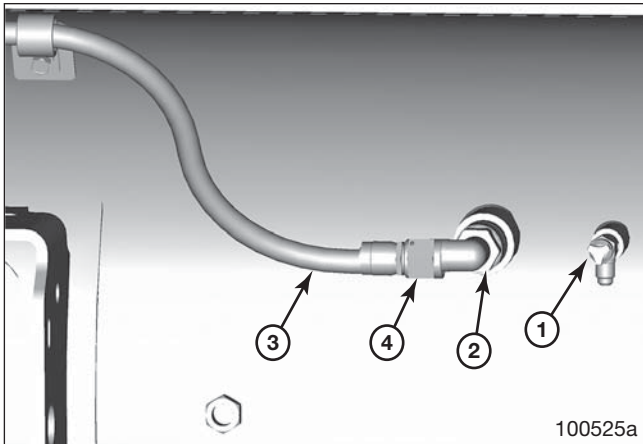

Figure 50 – Mechanical Fill Valve/OPD – F-650 Single Tank/F-59 Saddle Tank

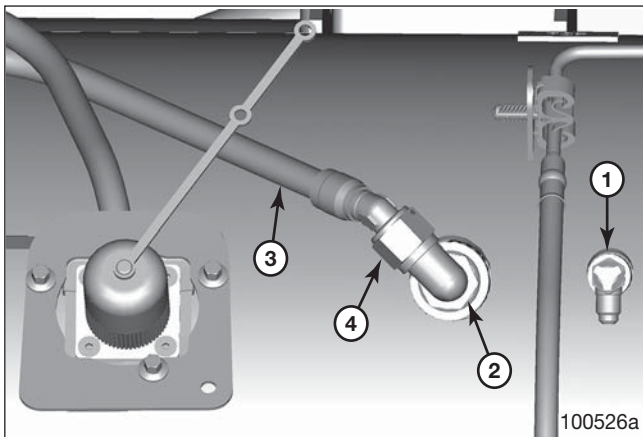

Figure 51 – Mechanical Fill Valve/OPD – F-650 LH Dual Tank

- | | |
|---|--------------------------------------|
| 1. Bleeder Valve | 3. Fuel Fill Line from Filter Outlet |
| 2. Mechanical Fill Valve/OPD (with 90-degree elbow) | 4. Fill Line Fitting |

4. Separate the 90-degree elbow from the mechanical fill valve.
5. Slowly remove the mechanical fill valve/OPD from the tank using caution as there may still be residual pressure in the tank.

Installation

1. Install the mechanical fill valve into the fuel tank. For valve P/N 66-1157B, tighten the valve to 71-79 Nm minimum. For valve P/N A10110100, tighten the valve to 100-108 Nm minimum. After reaching the minimum torque, further tighten the valve until the mark or notch is oriented vertically, or until the correct orientation is made.

CAUTION

The valve must **NOT** be tightened to align the notch vertically any more than one full turn after the initial minimum torque is achieved. Only rotate the valve enough to obtain the correct orientation of the notch. Do **NOT** rotate the valve counterclockwise (or loosen) to orient the notch. If the valve has been tightened (rotated) more than one full turn after reaching initial torque, damage to the valve can occur. Replace the valve with a new valve.

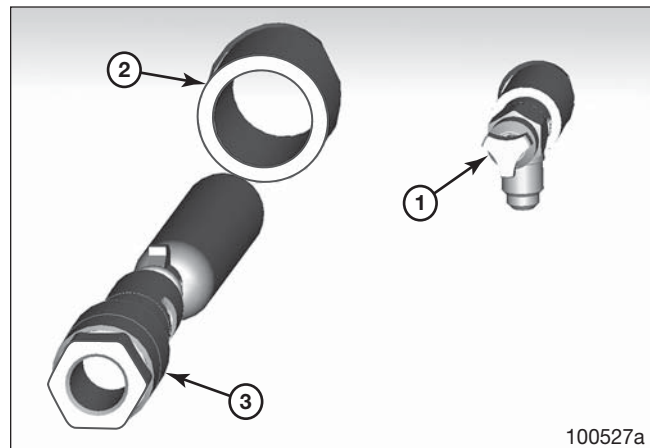

Figure 52 – Mechanical Fill Valve/OPD Installation

- | | |
|-------------------------------|------------------|
| 1. Fill Valve Opening in Tank | 3. Bleeder Valve |
| 2. Mechanical Fill Valve/OPD | |

NOTE

A mark or notch on the mechanical fill valve must face vertically upwards for the valve to work properly when installed and tightened to specification. The notch provides for ease of visibility during installation and is located on the face of the valve at the hex end. Use the notch to correctly orient the valve.

NOTE

For ease of visibility, highlight the mark at the end of the fitting with a marker before it is installed.

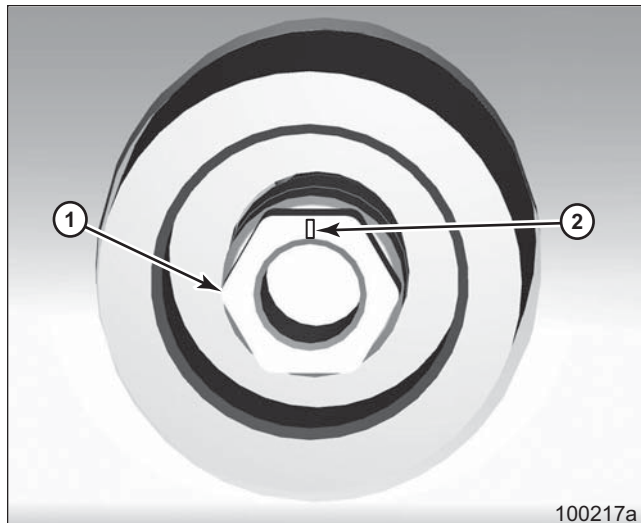

Figure 53 – Mechanical Fill Valve/OPD Orientation

1. Mechanical Fill Valve/OPD	2. Notch on Face of Fill Valve Must be Oriented Vertically
------------------------------	--

- Clean the threads of the 90-degree elbow and apply pipe thread sealant (PLS-2 or equivalent) to the threads of the elbow.
- Install the 90-degree elbow into the mechanical fill valve/OPD. For valve P/N 66-1157B, tighten the 90-degree elbow to 31-35 Nm minimum. For valve P/N A10110100, tighten the 90-degree elbow to 51-55 Nm minimum. Further tighten the elbow until it is oriented to align with the fuel fill line needed for the vehicle application.

CAUTION

Use a backup wrench on the mechanical fill valve to prevent the valve from rotating when tightening the 90-degree elbow. The elbow must NOT be tightened any more than one full turn after the initial minimum torque is achieved. Only rotate the elbow enough to obtain the correct orientation. Do NOT rotate the elbow counterclockwise (or loosen) to orient the elbow. If the elbow has been tightened (rotated) more than one full turn after reaching initial torque, damage to the mechanical fill valve/OPD can occur. Replace the valve with a new valve.

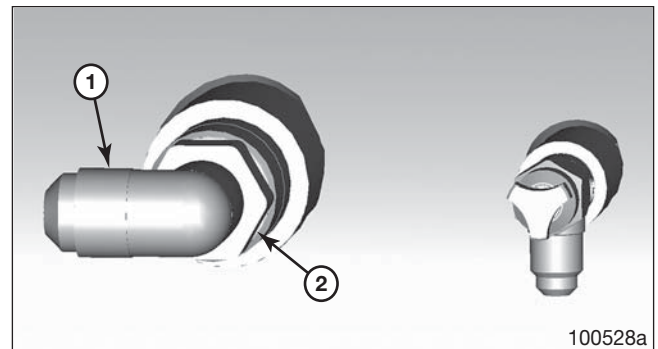

Figure 54 – F-650 Single Tank/F-59 Saddle Tank 90-Degree Elbow Orientation

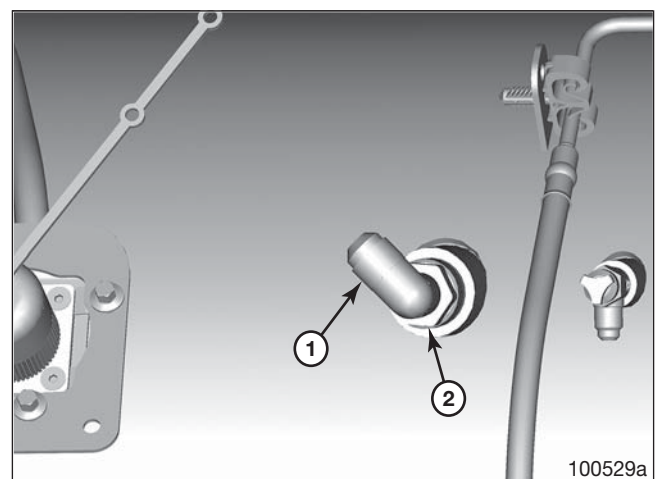

Figure 55 – F-650 LH Dual 90-Degree Elbow Orientation

1. 90-Degree Elbow Fitting	2. Mechanical Fill Valve/OPD
----------------------------	------------------------------

NOTE

Elbow orientation varies by application. Rotate the elbow to match the original orientation.

- Connect the fuel fill line (from fuel filter outlet) to the 90-degree elbow and tighten to 41-49 Nm.
- Purge the fuel tank. Refer to the *Fuel Tank Purging Procedure* for more information.
- Connect the negative battery cable to the battery.
- Fill the tank and leak check the valve and fittings using an electronic leak detector or leak detection solution.

Fuel Fill Line (Fuel Fill Valve-to-Filter)

⚠ DANGER

A trace amount of propane fuel is released when loosening the fittings. Propane settles to the lowest available surface before dissipating into the atmosphere. Keep heat, sparks, flames, static electricity or other sources of ignition out of the area when venting or purging the fuel lines or tank. Failure to heed this danger can result in severe personal injury or property damage.

Removal

1. Disconnect the fuel filler line from the fuel filter inlet.

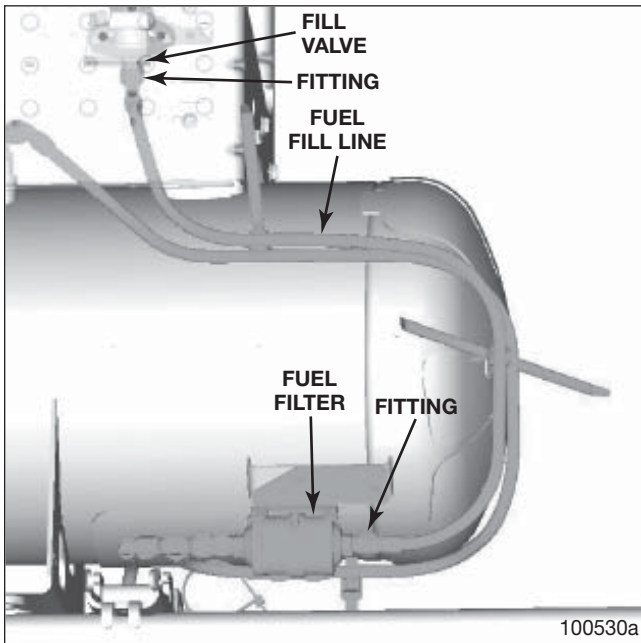

Figure 56 – F-650 LH Dual Tank

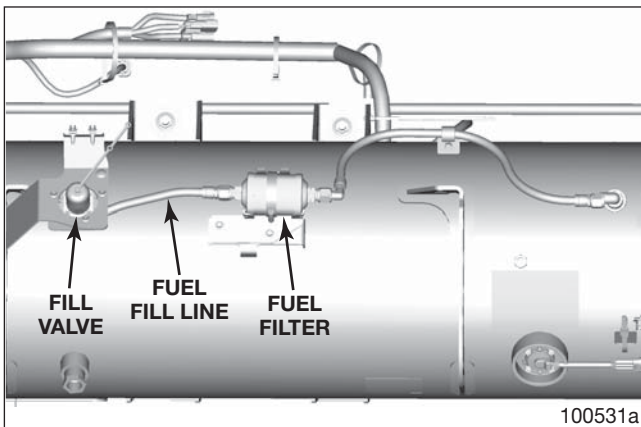

Figure 57 – F-650 Single and F-59 Saddle Tank

2. Disconnect the fuel filler line from the fuel fill valve.
3. Cut the zip ties and remove the two M6x45 bolts and M6 nuts securing the fill line to the tank tabs.
4. Remove the fuel fill line.
5. Remove the bolt and nut on the P-clamp securing the line to the tank. Remove the P-clamp from the line.

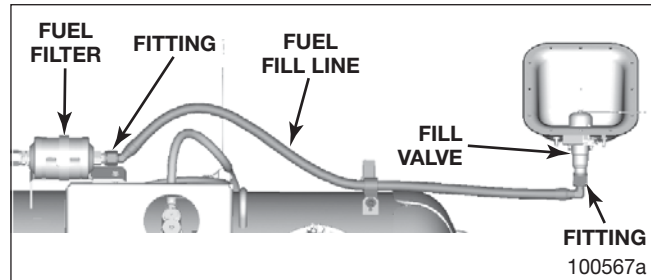

Figure 58 – F-59 Driver Side Fill System

6. Remove the two bolts and nuts from the P-clamps, securing the fill line across the crossmember. Remove the P-clamps from the line.

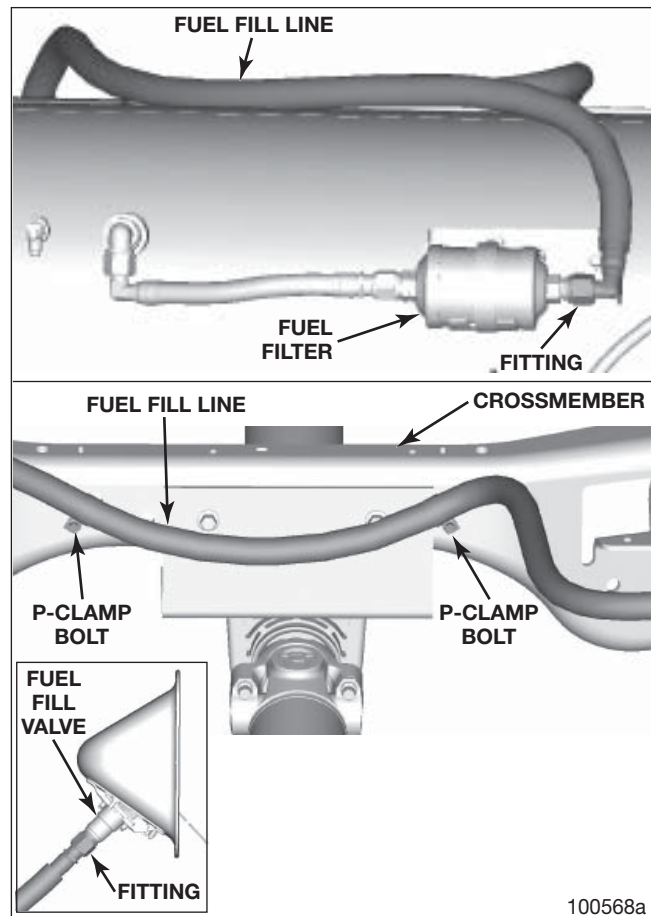

Figure 59 – F-59 Passenger Side Fill System

Installation

1. Route the fuel fill line from the fuel filter to the fuel fill valve.
2. Connect the fuel fill line to the fuel valve. Torque the fitting to 41-49 Nm.
3. Connect the fuel fill line to the fuel filter inlet. Torque the fitting to 53-61 Nm.

Retain both fill lines to the tank tabs as shown using two dual clamp zip ties, two M6x45 bolts and two M6 nuts.

Fuel Fill Line (Filter-to-Tank)



A trace amount of propane fuel is released when loosening the fittings. Propane settles to the lowest available surface before dissipating into the atmosphere. Keep heat, sparks, flames, static electricity or other sources of ignition out of the area when venting or purging the fuel lines or tank. Failure to heed this danger can result in severe personal injury or property damage.

Removal

1. Close the manual shutoff valve on the tank. Refer to *Manual Fuel Shutoff* for more information.
2. Disconnect the fuel fill line from the fuel filter.

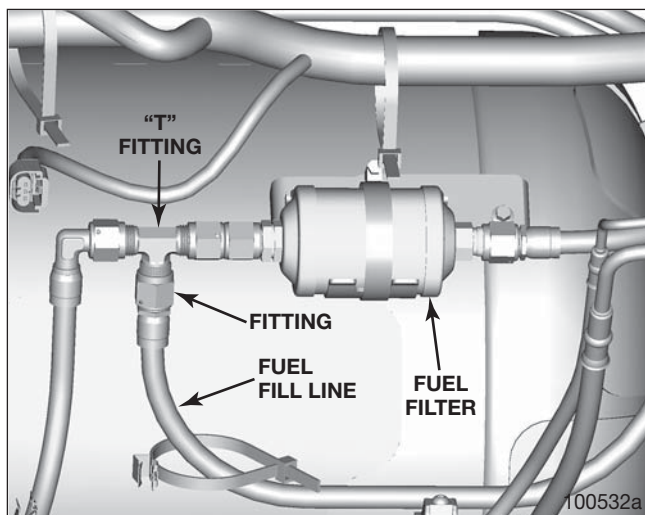

Figure 60 – F-650 LH Dual Tank

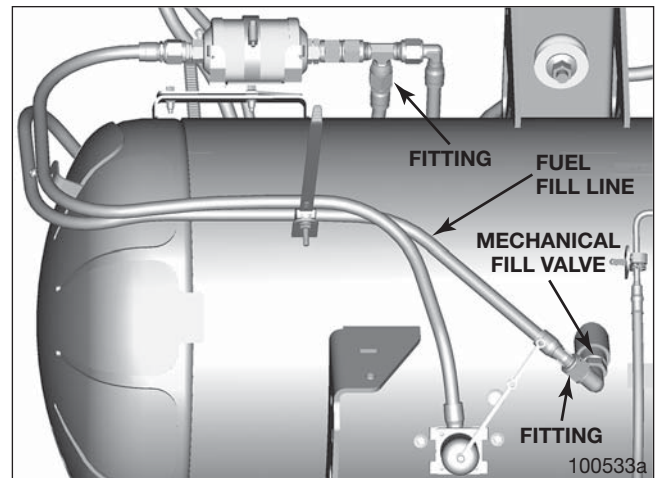

Figure 61 – F-650 LH Dual Tank

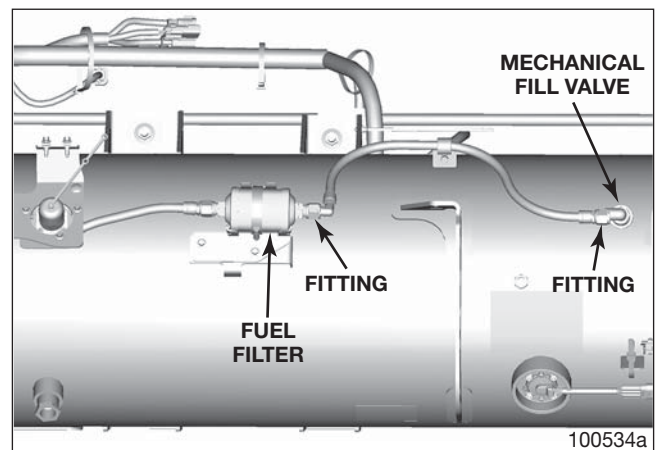

Figure 62 – F-650 Single and F-59 Saddle Tank

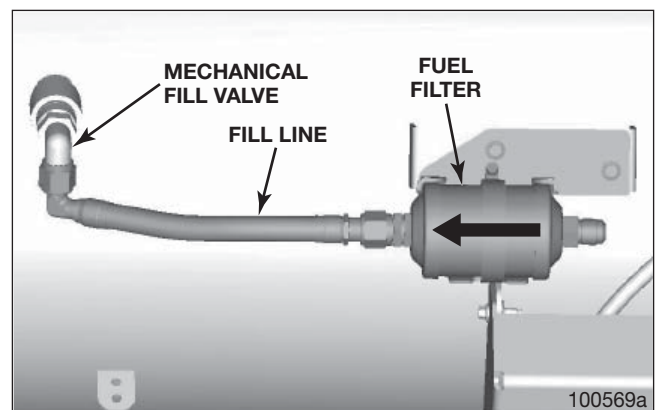

Figure 63 – F-59 Fuel Filter and Fill Line (Driver Side Fill)

3. Disconnect the fuel fill line from the mechanical fill valve.
4. For LH dual tank, clip the zip tie and remove the fuel fill line from the tank. For F-650 single and F-59 saddle tank, remove the line from the P-clip and remove the line from the tank.

Installation

1. Route the fuel fill line between the fuel filter and mechanical fill valve on the tank.
2. Connect the fuel fill line to the mechanical fill valve. Torque the fitting to 53-61 Nm.
3. Connect the fuel fill line to the fuel filter outlet. Torque the fitting to 53-61 Nm.
4. For LH dual tank, secure the line with a zip tie. For F-650 single and F-59 saddle tank, secure the line to the tank with a P-clamp.

Fuel Filler Valve (ACME)



A trace amount of propane fuel is released when loosening the fittings. Propane settles to the lowest available surface before dissipating into the atmosphere. Keep heat, sparks, flames, static electricity or other sources of ignition out of the area when venting or purging the fuel lines or tank. Failure to heed this danger can result in severe personal injury or property damage.

Removal

1. Disconnect the fuel filler line from the fuel filler valve.
2. Remove the three M5x0.9x16 bolts on the mounting bracket. Remove the fill valve assembly.

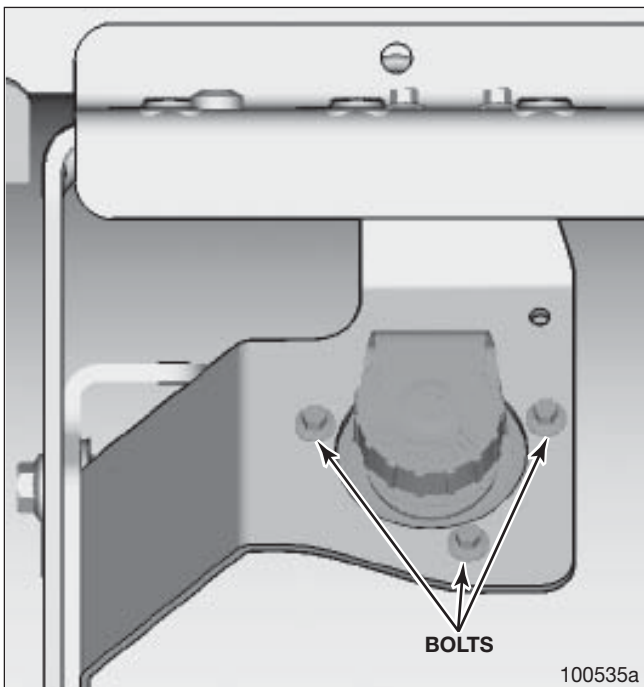

Figure 64 – Fill Valve Removal

3. Remove the nut and washer from the fill valve and remove the fill valve from the bracket.

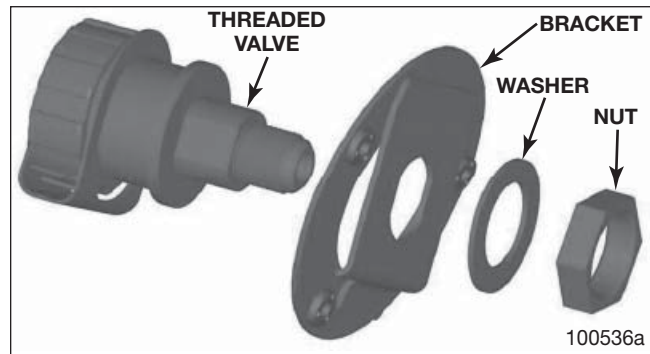

Figure 65 – Fill Valve Assembly

Installation

1. Remove the nut and washer from fuel fill valve and assemble the valve to the fuel fill bracket.
2. Support the fill valve and bracket assembly and tighten nut securely.
3. Install the fuel fill valve assembly to the tank mounting bracket using three M5x0.9x16 bolts. Torque the bolts to 5-7 Nm.
4. Connect the fuel fill line to the fuel fill valve. Torque the fitting to 41-49 Nm.

Fuel Filler Valve (EURO)

Removal

1. Disconnect the fuel filler line from the fuel filler valve.
2. Remove the three M5x0.9x16 bolts on the mounting bracket. Remove the fill valve assembly.

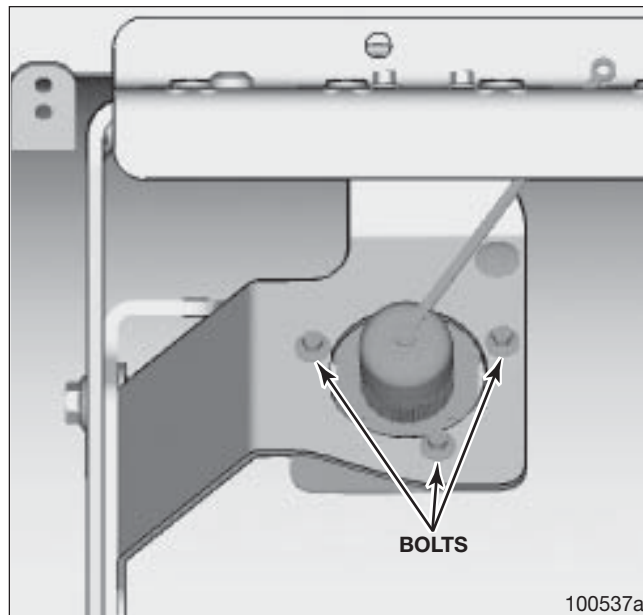

Figure 66 – Fill Valve Removal (EURO)

3. Remove the plastic rivet retaining the cap to the bracket. Remove the cap from the valve assembly.

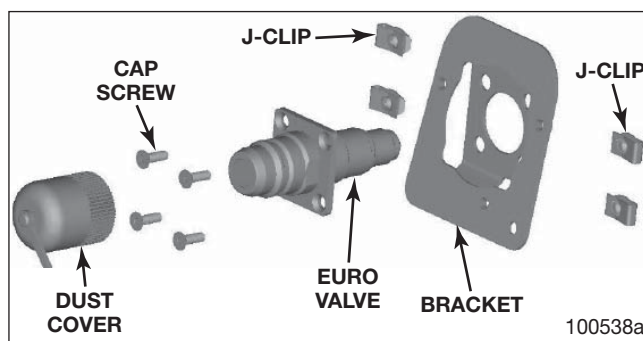

Figure 67 – Fill Valve Assembly (EURO)

4. Remove the M5x0.8x16 countersunk socket cap screws and remove the fill valve from the bracket.
5. Remove the four J-clips from the bracket.

Installation

1. Attach four M5 J-clips to the Euro valve bracket.
2. Attach the Euro valve to the bracket using four M5x0.8x16 countersunk socket cap screws. Torque the bolts to 5-7 Nm.
3. Install the fuel fill valve assembly to the body mounting bracket using three M5x0.9x16 bolts. Torque the bolts to 5-7 Nm.
4. Thread on the valve dust cover and retain the tether to the bracket using a nylon rivet.
5. Connect the fuel fill line to the valve. Torque the fitting to 41-49 Nm.

In-Line Fuel Filter

⚠ DANGER

A trace amount of propane fuel is released when loosening the fittings. Propane settles to the lowest available surface before dissipating into the atmosphere. Keep heat, sparks, flames, static electricity or other sources of ignition out of the area when venting or purging the fuel lines or tank. Failure to heed this danger can result in severe personal injury or property damage.

Removal

1. Purge the residual fuel from the fuel fill line. Refer to the *Fuel Line Purging* procedure.
2. Disconnect the fuel fill line from the fuel filter inlet.

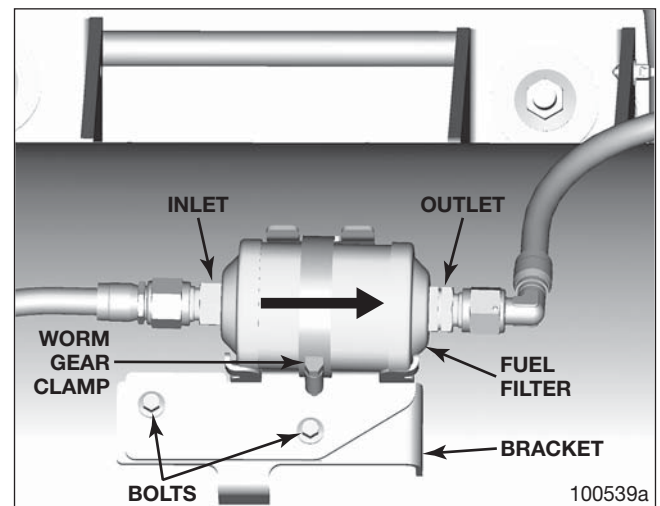

Figure 68 – F-650 Single and F-59 Saddle Tank

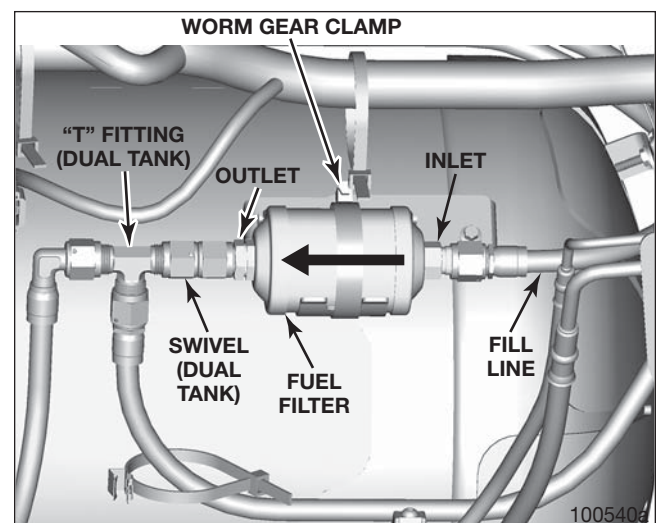

Figure 69 – F-650 LH Dual Tank

3. For F-650 dual tank, loosen the dual female swivel fitting on the filter assembly and remove the T-fitting along with the connected lines from the filter. For F-650 single and F-59 saddle tank, disconnect the fuel fill line from the fuel filter outlet.
4. Remove the two M6x16 bolts from the tank filter bracket and remove the bracket and filter from the tank.
5. Remove the two M6 J-clips from the tank.

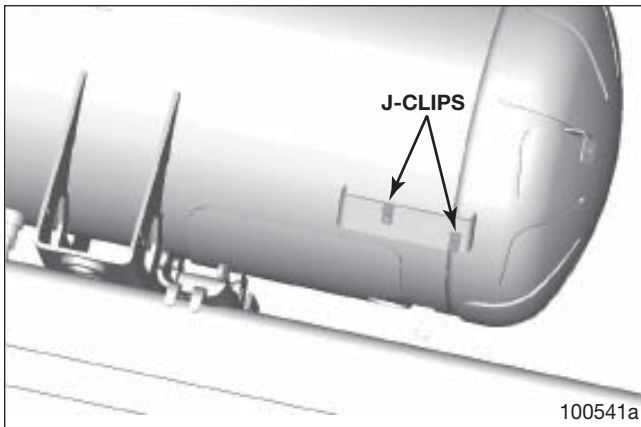

Figure 70 – F-650 LH Dual Tank Filter Mounting

6. Loosen the worm gear clamp and remove the fuel filter from the filter bracket.

Installation

1. Assemble the fill filter to the fuel filter bracket using a worm gear clamp. Make sure that the fuel flow direction on the filter is oriented correctly. Tighten the clamp to secure the filter to the bracket.
2. Install two M6 J-clips on the LH fuel tank inboard filter mounting bracket.
3. Install the assembly on the tank filter bracket as shown using two M6x16 bolts into the J-clips you installed during step 1. Torque 8-12 Nm.
4. For F-650 dual tank, install the dual female swivel and connected lines to the filter, torque to 53-61 Nm. For F-650 single and F-59 saddle tank, install the fuel fill line to the fuel filter outlet, torque to 53-61 Nm.
5. Connect the fuel fill line to the fuel filter inlet. Torque the fitting to 53-61 Nm.

Supply Filter

Removal

1. Disconnect the supply line from the supply filter.

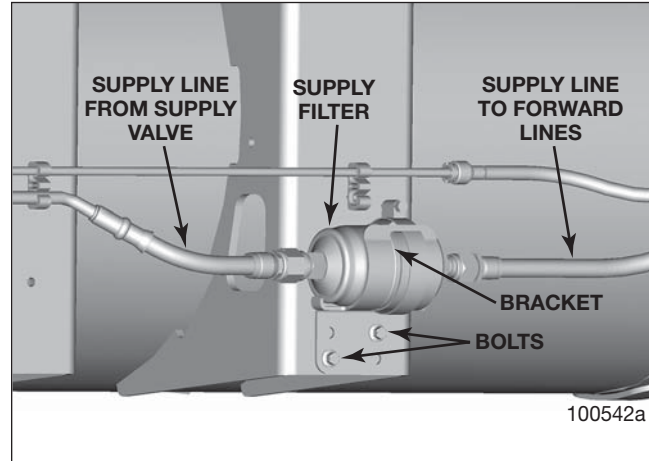

Figure 71 – Supply Filter Assembly

2. Disconnect the supply flexline from the supply filter.
3. Remove the two M6x16 bolts from the LH tank filter bracket and remove the bracket and filter from the tank.
4. Remove the four edge clips on the rearmost LH fuel tank mounting bracket as shown.
5. Loosen the worm gear clamp and remove the supply filter from the supply filter bracket.
6. Remove the four edge clips on the rearmost LH fuel tank mounting bracket as shown.

Installation

1. Assemble the supply filter to the supply filter bracket using a worm gear clamp. Make sure that the fuel flow direction on the filter is oriented correctly as shown. Tighten the clamp to secure the filter to the bracket.
2. Install four edge clips on the rearmost LH fuel tank mounting bracket as shown.
3. Attach the supply filter assembly to the LH tank's forward most mounting bracket using two M6x16 bolts and two M6 nuts. Torque to 8-12 Nm.
4. Thread the rear supply flexline into the supply line filter. Using two wrenches, torque to 24-32 Nm.
5. Thread the tank supply line into the supply line filter. Torque to 53-61 Nm.

REPAIR PROCEDURES

Fuel Supply and Return Lines

1. Purge the propane from the fuel lines. Refer to the *Fuel Line Purging* procedure for more information.
2. Remove the tank cover plate. Refer to the *Tank Cover Plate* procedure for more information.
3. Close the manual shutoff valve on the tank. Refer to *Manual Fuel Shutoff* for more information.
4. If necessary, raise the fuel tank to gain access to the intank fuel supply and return lines. Refer to *Fuel Tank* for more information.

NOTE

Removing or disconnecting fuel lines requires the use of the appropriate Jiffy-Tite disconnect tool. Refer to *Tools and Equipment, Special Tools* for more information.

Rear Supply and Return Lines

WARNING

Technicians working with, or around, fuel systems should be properly trained to utilize extreme care and caution at all times. Failure to exercise extreme caution and care may lead to serious accidents which can result in property damage, personal injury and/or death.

WARNING

LPG is under pressure, wear adequate eye protection. When LPG is discharged into the atmosphere, the rapid change in pressure can cause a refrigerant condition in the fuel and can harm your skin or cause serious burns, always wear gloves.

NOTE

Removing or disconnecting fuel lines requires the use of the appropriate Jiffy-Tite disconnect tool. Refer to *Tools and Equipment, Special Tools* for more information.

NOTE

When removing lines, slowly disconnect at the fuel line joints, using the appropriate disconnect tool, allowing any excess propane to dissipate into the atmosphere.

NOTE

The fuel supply and return lines are made of special material and should only be replaced or repaired using original equipment parts.

Removal

1. Disconnect the return line from the return valve on the outboard side of the tank.

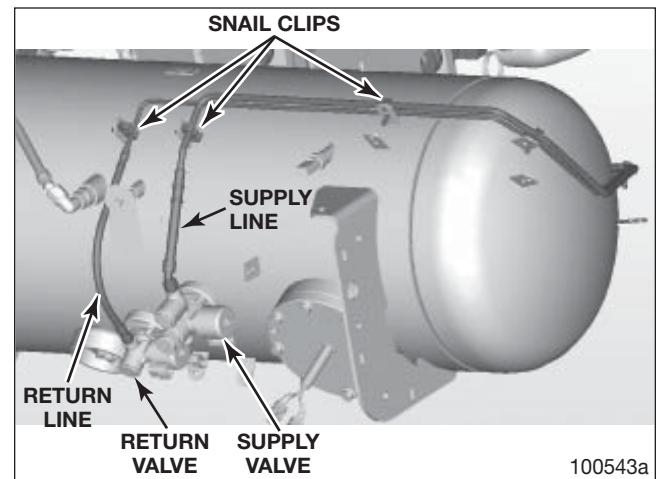

Figure 72 – Front View, All Models

2. Disconnect the rear return line from the forward fuel return line.
3. Remove the fuel return line from the snail clips on the fuel tank.

NOTE

On F-650 single tanks, the supply and return lines are mounted on the outside of the tank mounting brackets.

4. Dual Tank Only: Cut the zip ties retaining the fuel return line where it passes through the tank mounting bracket on each side.
5. Remove the rear return line from the fuel tank. Make sure to clear the tank mounting bracket when removing the line.

6. Disconnect the supply line from the supply valve on the outboard side of the tank.
7. Disconnect the supply line from the supply line filter.
8. Remove the fuel supply line from the four snail clips on the rear of the fuel tank.
9. Dual Tank Only: Cut the zip ties retaining the fuel supply line where it passes through the tank mounting bracket on each side.
10. Remove the rear supply line from the fuel tank. Make sure to clear the tank mounting bracket when removing the line.

Installation

1. Route the rear supply line through the tank mounting bracket and along the rear end of the fuel tank as shown. For F-650 single tanks, route the line on the outside of the outside of the tank mounting bracket.
2. Dual Tank Only: Retain the fuel supply line where it passes through the tank mounting bracket on each side using two previously installed edge clips with zip ties.

3. Retain the fuel supply line on the rear of the fuel tank using four previously installed snail clips.
4. Thread the supply line into the supply line filter. Torque to 53-61 Nm.
5. Thread the supply line into the supply valve on the outboard side of the tank. Torque to 29-33 Nm. Make sure the line does not touch or rub other lines/brackets.
6. Route the rear return line through the tank mounting bracket and along the rear end of the fuel tank as shown. For F-650 single tanks, route the line on the outside of the outside of the tank mounting bracket.
7. Dual Tank Only: Retain the fuel return line where it passes through the tank mounting bracket on each side using two previously installed edge clips with zip ties.
8. Retain the fuel return line on the fuel tank using the five previously installed snail clips.
9. Connect the rear return line to the forward fuel return line.
10. Thread the return line into the return valve on the outboard side of the tank. Torque to 18-20 Nm. Make sure the line does not touch or rub other lines/brackets.

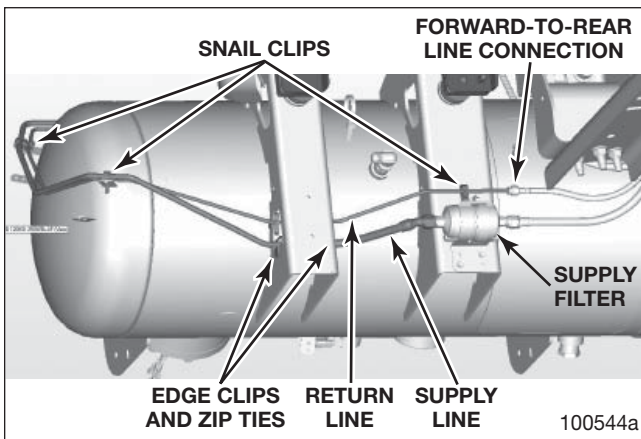

Figure 73 – F-650 Dual Tank Rear

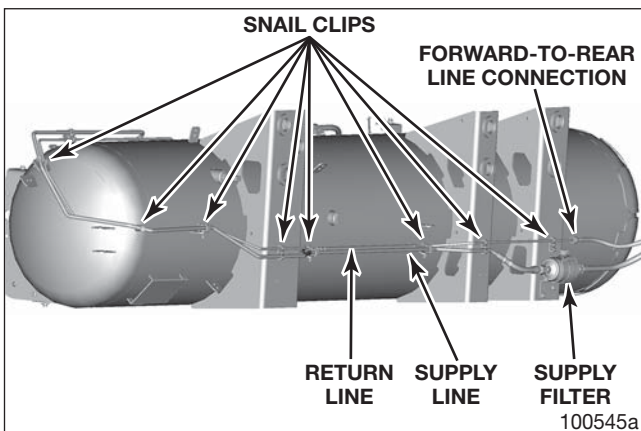

Figure 74 – F-650 Single Tank Rear

F-59 Only

Removal

1. Purge the fuel lines using the *Fuel Line Purging Procedure*.
2. Disconnect the return line from the return valve on the outboard side of the tank.

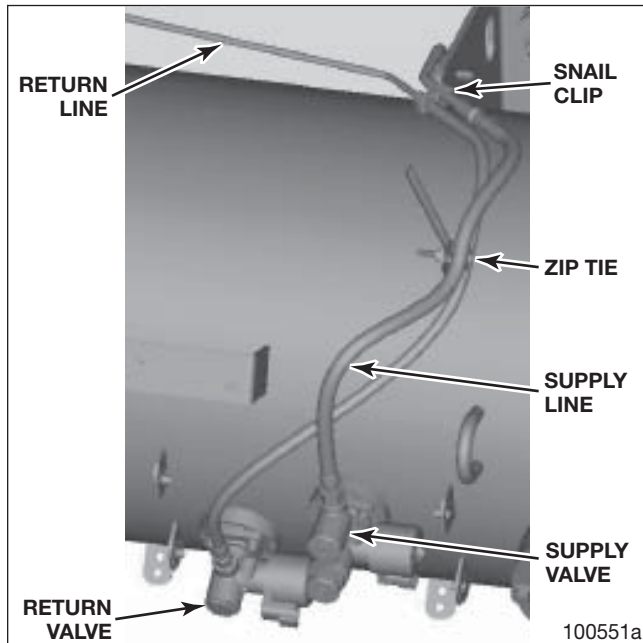

Figure 75 – F-59 Rear Supply and Return Lines

3. Cut the zip tie retaining the supply and return lines on the front of the tank.
4. Disconnect the rear return line from the forward fuel return line on the inboard side of the tank.

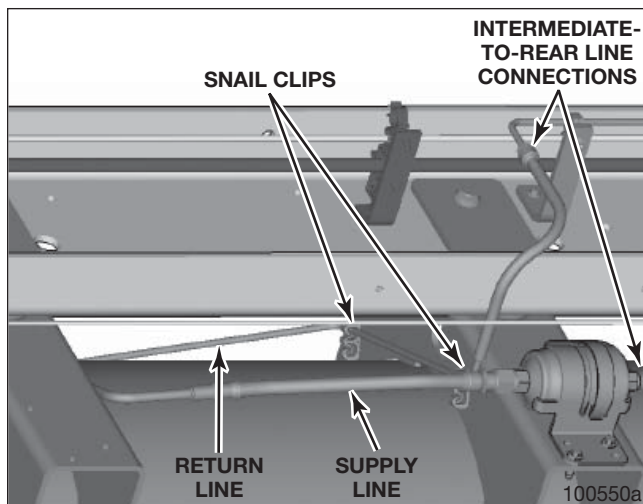

Figure 76 – F-59 Rear Supply and Return Lines

5. Remove the fuel return line from the three snail clips on the fuel tank.

6. Remove the rear return line from the fuel tank.
7. Disconnect the supply line from the supply valve on the outboard side of the tank.
8. Disconnect the supply line from the supply line filter on the inboard side of the tank.
9. Remove the fuel supply line from the two snail clips on the fuel tank.

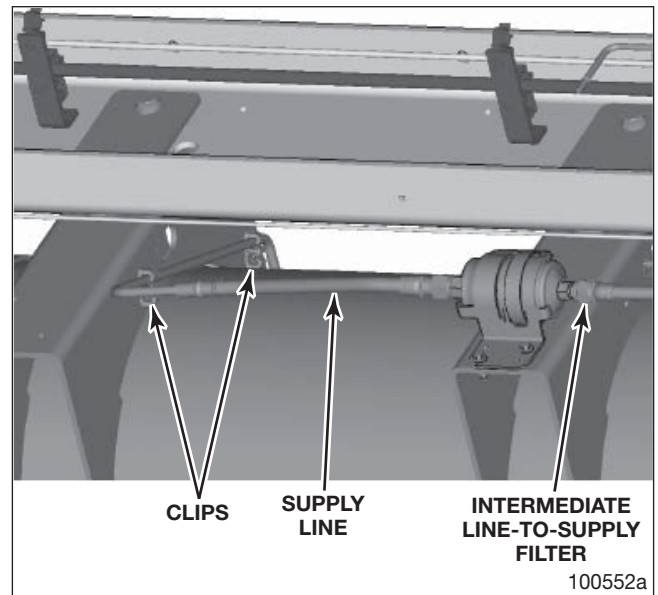

Figure 77 – F-59 Rear Supply and Return Lines

10. Remove the rear supply line from the fuel tank.

Installation

1. Place the return line in position on the tank and install it into the three snail clips. Figure 75 and Figure 76.
2. Place the supply line in position on the tank and install it into the two snail clips. Figure 76 and Figure 77.
3. Thread the return line into the return valve on the outboard side of the tank. Torque to 18-20 Nm. Make sure the line does not touch or rub other lines/brackets.
4. Thread the supply line into the supply valve on the outboard side of the tank. Torque to 29-33 Nm. Make sure the line does not touch or rub other lines/brackets.
5. Thread the supply line into the supply line filter. Torque to 53-61 Nm.
6. Connect the rear return line to the forward return line. Torque the fitting.
7. Secure the lines together to the tank using a zip tie as shown in Figure 75.

**Crossover Fuel Fill Line and Transfer Line
(F-650 Dual Tanks Only)**

Removal

1. Disconnect the transfer fuel fill line from the fill valve on the inboard of the LH fuel tank.

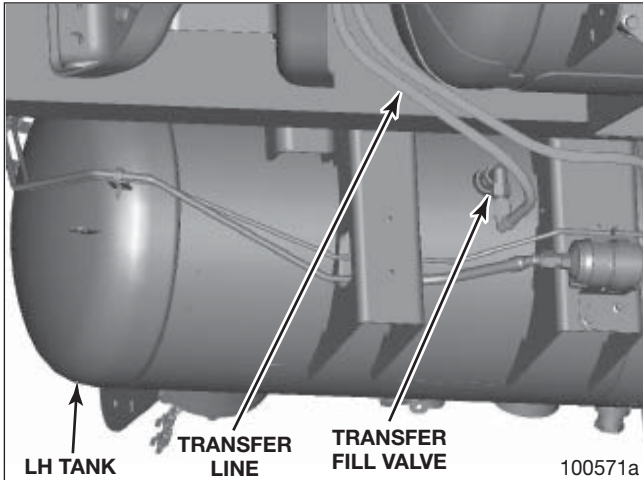

Figure 78 – Transfer Lines

2. Disconnect the end of the transfer line from the RH tank supply valve.

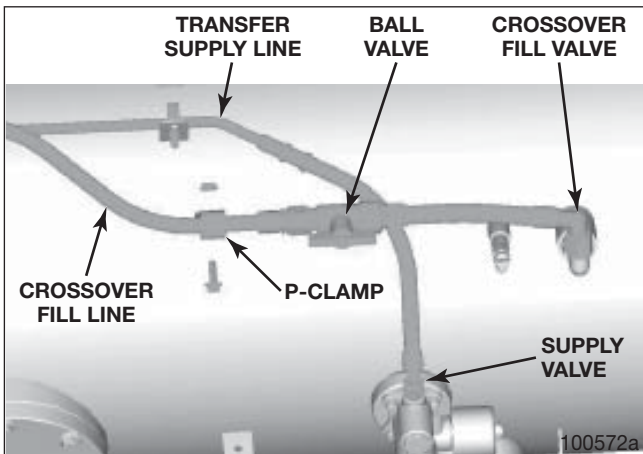

Figure 79 – RH Tank Crossover and Transfer Lines

3. Remove the M6x20 bolt and M6 nut and remove the crossover fill line from P-clamp.
4. Disconnect the ball valve from the crossover fuel fill line.
5. Pull the fuel lines out of the snail clips and remove the fuel lines from around the tank as shown.

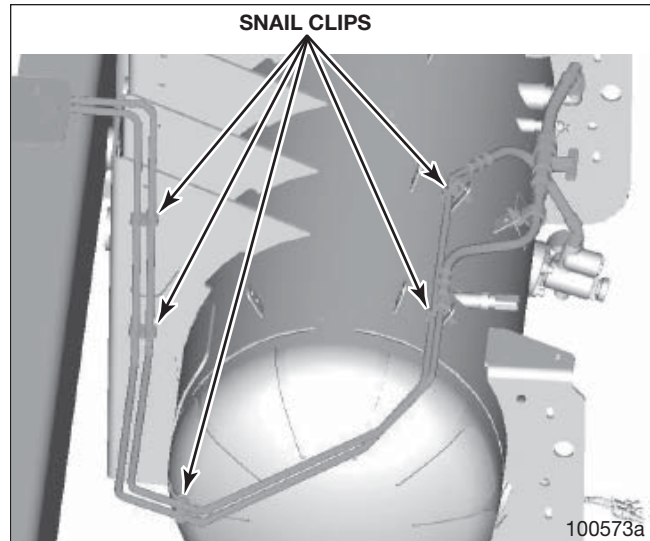

Figure 80 – Snail Clips

6. Remove both lines from the metal edge clip and zip tie at the cross member.

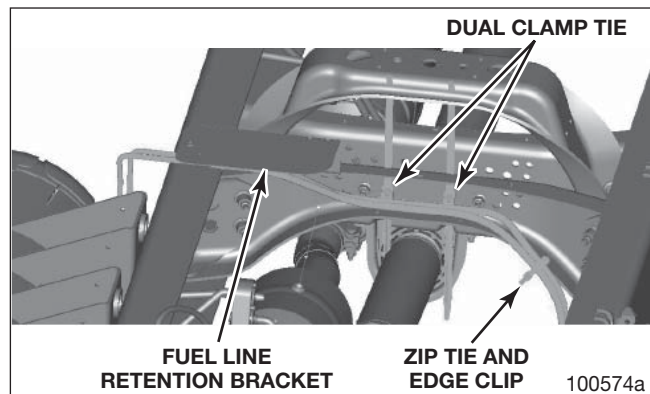

Figure 81 – Lines Across Cross Member

7. Remove both the lines from the two locations at the bottom of the dual clamp tie.
8. Remove both lines from the snail clip on the fuel line retention bracket. Also remove the convolute heat wrap from both fuel lines between the retention bracket and dual clamp zip ties.

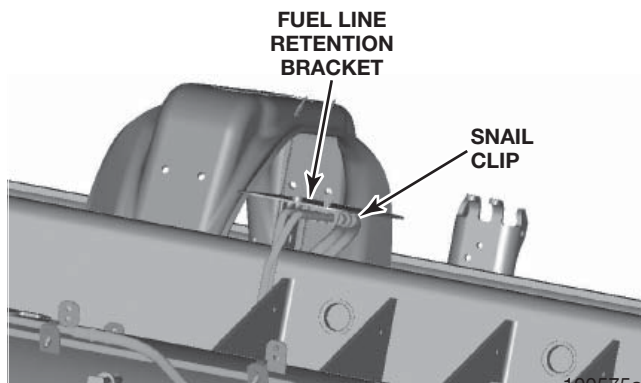

Figure 82 – Remove Lines

9. Remove the fuel fill line and transfer line.
10. Disconnect the ball valve. Figure 79.
11. Disconnect the fuel fill line from the fill valve on the RH fuel tank.

Installation

1. Install the fuel fill line to the fill valve on the RH fuel tank and torque to 41-49 Nm.
2. Install the ball valve and torque to 41-49 Nm.
3. Install the fuel fill line and transfer line as shown. Start by routing the long flex ends of each fuel line from the RH tank side (passenger side) and the feed over the frame rail.
4. Hand tighten the fuel transfer fill line to the OPD valve present on the inboard of the LH fuel tank.
5. Leave the LH side of the fill line loose. You will install this later.
6. Retain both lines using a metal edge clip and zip tie to the cross member to protect the lines from rubbing on the lower flange of the cross member where they pass over it.
7. Retain both the lines at two locations to the bottom of the dual clamp tie as shown. Note that the RCT electrical harness is retained on the top of the dual clamp tie, so make sure to only use the bottom. Also, make sure the dual clamp ties align with the OEM mounting holes on the cross member and then tighten the zip tie but do not fasten it to the cross member until you have installed the electrical harness.
8. Install a snail clip into the fuel line retention bracket and then snap the fuel lines in the clips.

NOTE

The fill line is in front and the transfer line routes behind it.

9. Install the fuel lines around the tank as shown by snapping them into the snail clips.
10. Thread the fuel fill line into the ball valve and torque to 41-49 Nm.
11. Retain the fill line using a P-clamp as shown using an M6x20 bolt and M6 nut. Torque to 8-12 Nm.
12. Thread the end of the transfer line into the RH tank supply valve. Torque to 29-33 Nm.
13. Torque the LH end of the transfer line to 41-49 Nm.

Intermediate Supply and Return Lines (F-59 Only)

WARNING

Technicians working with, or around, fuel systems should be properly trained to utilize extreme care and caution at all times. Failure to exercise extreme caution and care may lead to serious accidents which can result in property damage, personal injury and/or death.

WARNING

LPG is under pressure, wear adequate eye protection. When LPG is discharged into the atmosphere, the rapid change in pressure can cause a refrigerant condition in the fuel and can harm your skin or cause serious burns, always wear gloves.

NOTE

Removing or disconnecting fuel lines requires the use of the appropriate disconnect tool. Refer to *Tools and Equipment, Special Tools* for more information.

NOTE

When removing lines, slowly disconnect at the fuel line joints, using the appropriate disconnect tool, allowing any excess propane to dissipate into the atmosphere.

NOTE

The fuel supply and return lines are made of special material and should only be replaced or repaired using original equipment parts.

Removal and Replacement

1. Disconnect the forward supply and return lines from the intermediate lines.

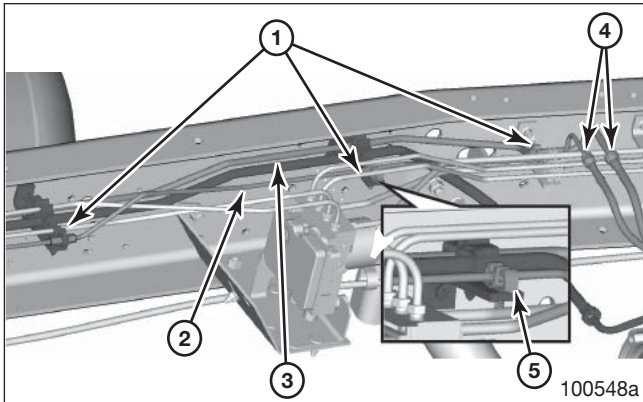

Figure 83 – Forward Supply and Return Lines

1. Clips and Retainers	4. Intermediate-to-Forward Line Connections
2. Return Line	5. Snail Clip
3. Supply Line	

2. Disengage the intermediate supply and return lines from the clips securing them along the frame rail.
3. Disconnect the intermediate supply and return lines from the rear supply and return lines.

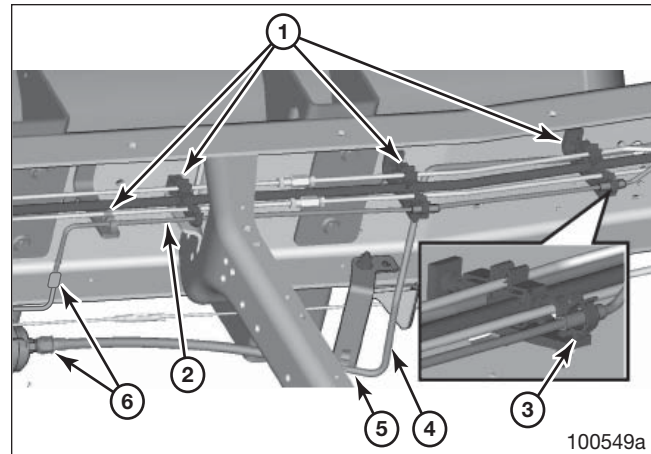

Figure 84 – Intermediate Supply and Return Lines

1. Clips and Retainers	4. Supply Line
2. Return Line	5. Support Bracket Retainer
3. Clip	6. Intermediate-to-Rear Line Connections

4. Disengage the intermediate supply and return lines from the clips securing them along the frame rail.
5. Remove the supply line from the retainer on the support bracket.
6. Remove the intermediate supply and return lines from the frame rail.
7. To install the intermediate supply and return lines, reverse the removal procedure. Make sure all fuel lines are retained securely in all clips and retainers.

Forward Supply and Return Lines

⚠ WARNING

Technicians working with, or around, fuel systems should be properly trained to utilize extreme care and caution at all times. Failure to exercise extreme caution and care may lead to serious accidents which can result in property damage, personal injury and/or death.

⚠ WARNING

LPG is under pressure, wear adequate eye protection. When LPG is discharged into the atmosphere, the rapid change in pressure can cause a refrigerant condition in the fuel and can harm your skin or cause serious burns, always wear gloves.

REPAIR PROCEDURES

NOTE

Removing or disconnecting fuel lines requires the use of the appropriate Jiffy-Tite disconnect tool. Refer to *Tools and Equipment, Special Tools* for more information.

NOTE

When removing lines, slowly disconnect at the fuel line joints, using the appropriate disconnect tool, allowing any excess propane to dissipate into the atmosphere.

NOTE

The fuel supply and return lines are made of special material and should only be replaced or repaired using original equipment parts.

Removal and Replacement

1. Disconnect the forward fuel supply and return lines from the FRPCM.

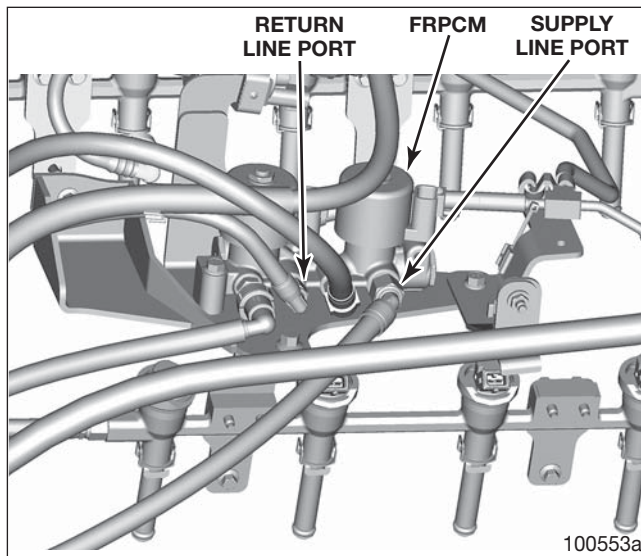

Figure 85 – FRPCM Connections

2. Cut any tie straps and disengage any clips securing the forward fuel lines to the engine, transmission and along the frame rails.

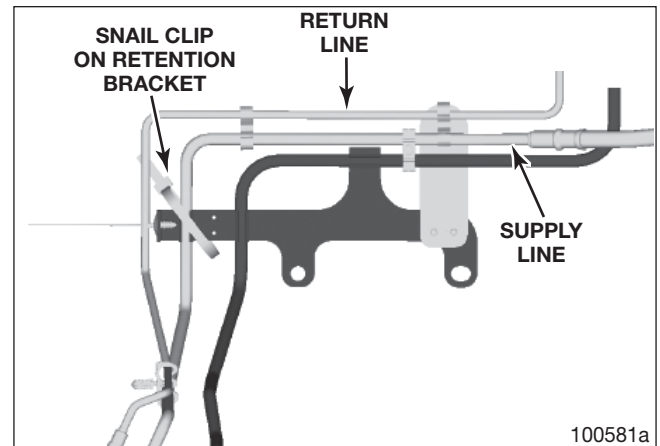

Figure 86 – Supply and Return Lines

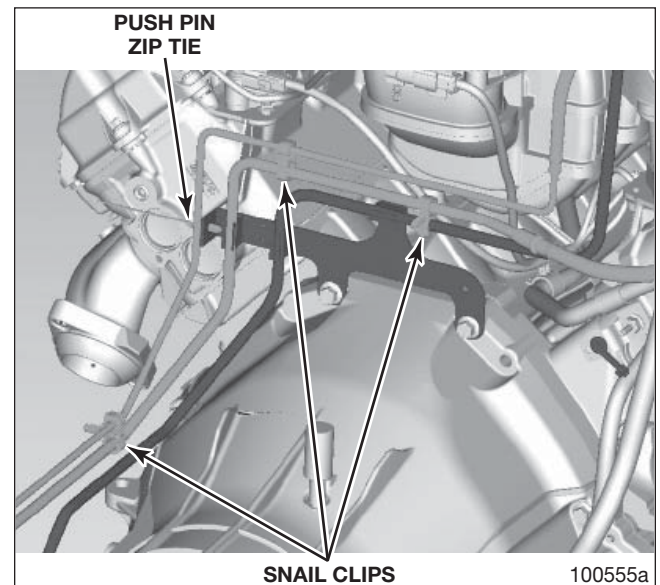

Figure 87 – Supply and Return Lines Retained in Transmission Bracket

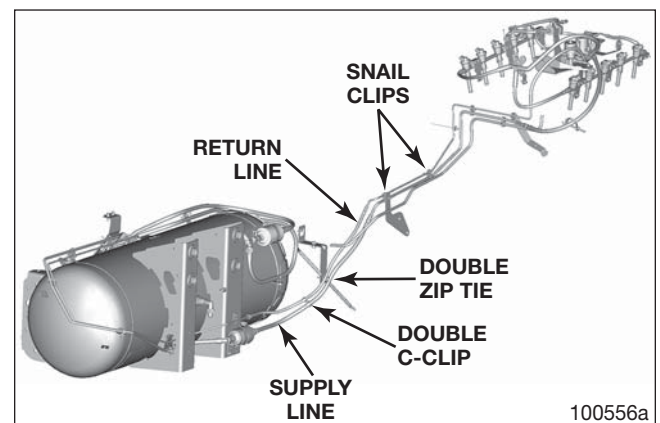

Figure 88 – F-650 LH Dual Tank Supply and Return Lines

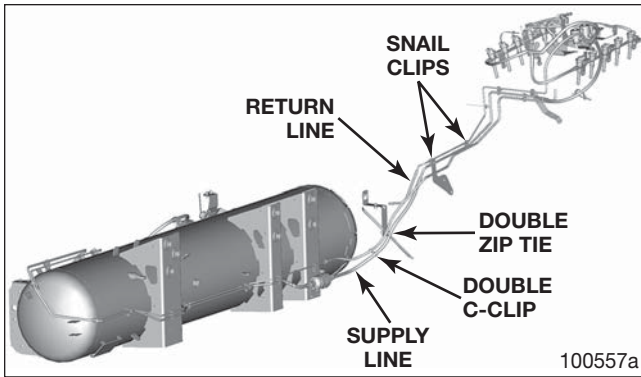

Figure 89 – F-650 Single and F-59 Saddle Tank Supply and Return Lines

3. Disconnect the forward fuel lines from the rear fuel lines.
4. Remove the forward fuel lines.
5. To install the forward fuel lines, reverse the removal procedure. Make sure all fuel lines are retained correctly and all quick-connect fittings are securely engaged. Ensure the forward lines to the FRPCM are installed to the correct port on reassembly.

NOTE

The forward line should route over the engine supply line.

Fuel Rail Pressure Control Module

Removal

1. Purge the propane from the fuel lines. Refer to the *Fuel Line Purging* procedure for more information.
2. Close the manual shutoff valve on the tank. Refer to *Manual Fuel Shutoff* for more information.
3. Disconnect the supply solenoid and bleed solenoid electrical connectors from the FRPCM. Figure 90.

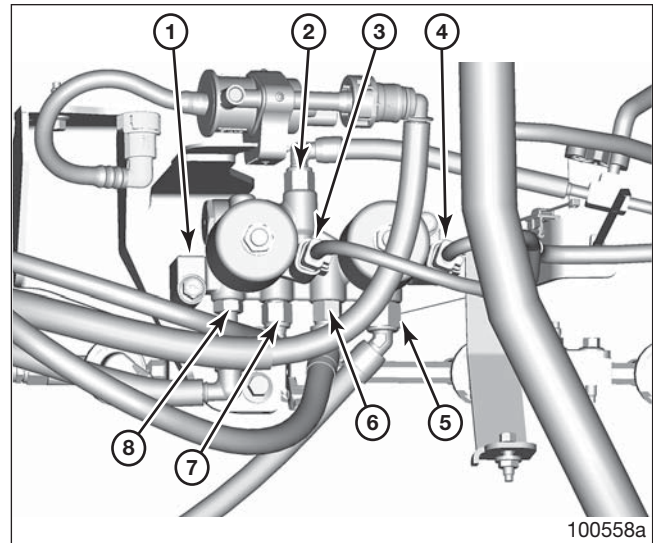

Figure 90 – FRPCM Connections

1. FRPCM	5. Fuel Supply
2. Engine Return	6. Engine Supply
3. Bleed Solenoid Connector	7. Fuel Return
4. Supply Solenoid Connector	8. Vapor Bleed

4. Note the location of the fuel return, engine supply and fuel supply ports on the front of the FRPCM. Disconnect lines from the FRPCM.
5. Disconnect the vapor hose assembly from the vapor management purge valve and vapor/bleed port on the FRPCM. Move the line out of the way or remove it to gain access.

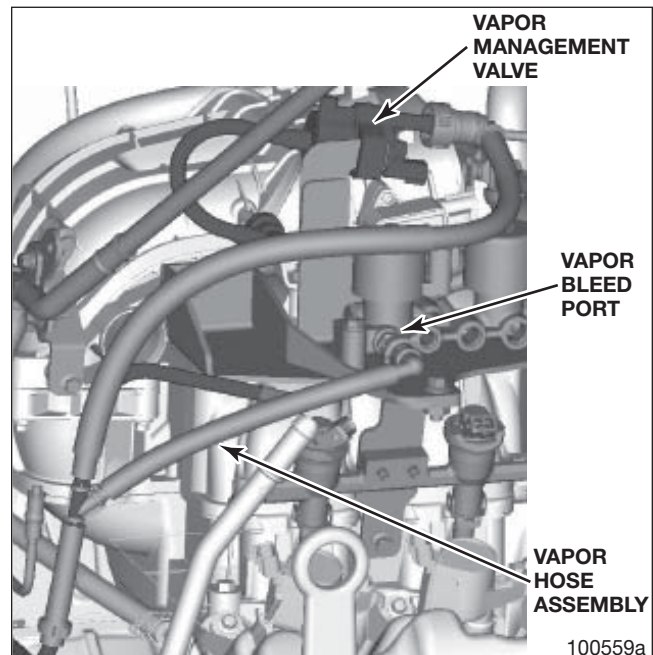

Figure 91 – Vapor Hose Assembly

6. Remove the vapor management valve from the bracket.
7. Note the location of the engine return line on the opposite side of the module. Disconnect the line. If necessary, remove the engine return line from the FRPCM bracket clip.

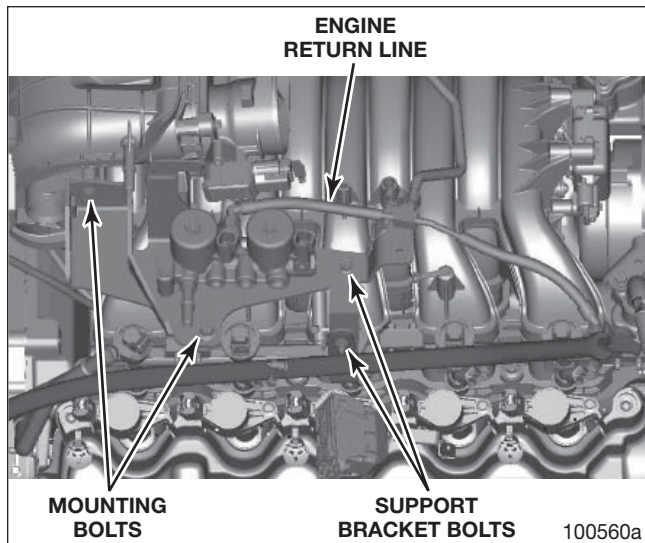

Figure 92 – FRPCM

8. Remove the two support bracket bolts and two FRPCM mounting bolts. Remove the FRPCM.
9. Remove the two flange head bolts and serrated nuts and remove the FRPCM from the bracket.

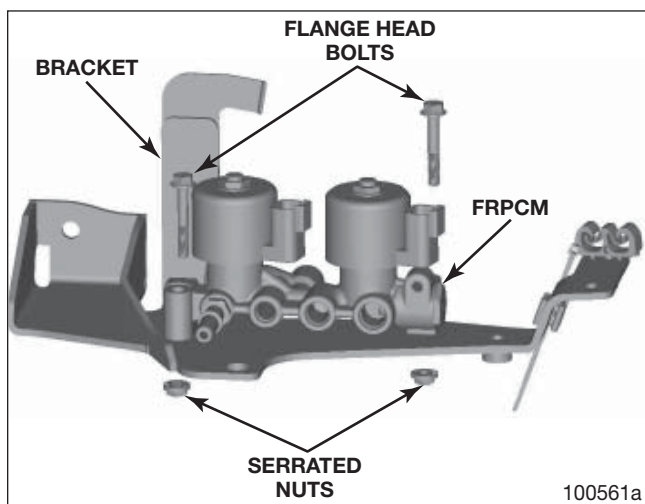

Figure 93 – FRPCM

Installation

1. Install the FRPCM on the bracket and secure it with two flange head bolts and serrated nuts. Figure 93. Torque the bolts to 8-12 Nm.
2. Place the FRPCM in position on the engine. Install two support bracket bolts and FRPCM mounting bolt. Torque the bolts to 8-12 Nm.
3. Install the M8 x 1.25 x 20 flange head bolt to the side of the fuel rail mounting bracket. Torque the bolt to 20-30 Nm.
4. Install the engine return line on the FRPCM. Connect the line to the port on the FRPCM. Secure the engine return line in the FRPCM bracket clip. Figure 92.
5. Install the fuel return, engine supply and fuel supply lines to the FRPCM. Ensure the lines are connected to the correct ports shown in Figure 90.

NOTE

All FRPCM lines on the side with bleed port must be torqued at the time of installation and they must be installed in the order listed below if the bleed port is installed.

6. Torque the line fittings as follows:
 - Forward return line: 18-20 Nm
 - Engine supply line: 23-26 Nm
 - Forward supply line: 29-33 Nm
 - Engine return line: 20-22 Nm
7. Install the vapor management valve on the bracket.
8. Install the vapor hose assembly on the vapor management purge valve and vapor/bleed port on the FRPCM. Torque the vapor/bleed port to 18-20 Nm. Figure 91.
9. Connect the supply solenoid and bleed solenoid electrical connectors to the FRPCM. Ensure the connectors are installed in the correct positions shown in Figure 90.

Fuel Rail Service

CAUTION

When removing or replacing any fuel delivery components which include: fuel rails, injectors, or supply lines, thoroughly clean the work area with solvents and compressed air to remove any debris or contaminants. Always insure your hands are clean when handling fuel injection components to prevent contaminating the fuel delivery systems.

CAUTION

Contamination may cause the injectors to stick, leak, or become damaged, delivering incorrect amounts of fuel and causing the fuel control system to be non-compliant.

NOTE

Always cap any open ports after disconnecting fuel lines, removing injectors or the fuel rails to prevent contamination of the fuel delivery system.

When removing the fuel rails use the following procedure.

Removal

1. Purge the fuel lines using the *Fuel Line Purging Procedure*.

CAUTION

Ensure the battery ground wires are disconnected before proceeding.

2. Disconnect the injection pressure and temperature sensor (IPTs) electrical connector.
3. Disconnect the fuel injector electrical connectors.
4. Disconnect the fuel rail supply and return hoses from the fuel rails.

NOTE

The fuel rail return line and tee assembly connects the two fuel rails at the front with a tee connection to the FRPCM fuel return port. The fuel rail supply line and tee assembly connects the two fuel rails at the rear with a tee connection to the FRPCM fuel supply port.

5. Remove the bolt connecting the right side fuel rail to the FRPCM bracket.
6. Remove the two bolts connecting the FRPCM bracket to the intake manifold.
7. Remove the fuel rail mounting brackets from the intake manifold.
8. Remove the fuel rail assembly.

Replacement

1. Lubricate the injector spacer lower O-rings using SAE 5W20 motor oil or equivalent.

NOTE

It is recommended to replace the fuel rail O-rings during servicing.

2. Position the fuel rail assemblies onto the intake manifold and fully seat the injector spacers.
3. Install and tighten the fuel rail to the intake manifold mounting brackets to the specified torque.
 - a. M5 Bolt: 5.8 +/-1.2 Nm
 - b. M6 Bolts: 10 +/-2 Nm
4. Install the two bolts connecting the FRPCM bracket to the intake manifold. Torque to 10 +/-2 Nm.
5. Install the bolt connecting the right side fuel rail to the FRPCM bracket. Torque to 25 +/-5 Nm.
6. Install the fuel rail supply and return lines on the fuel rail. Torque to: fuel rail supply line 23-26 Nm, fuel rail return line 20-22 Nm.
7. Connect the fuel injector electrical connectors.
8. Connect the IPTs electrical connector.
9. Connect the vehicle batteries.
10. Open the manual shut-off valve on the fuel tank and install the supply circuit cover.
11. Perform the *Fuel System Priming Procedure*.
12. Check the fuel line and rail connections for leaks using an electronic leak detector or leak detection solution.

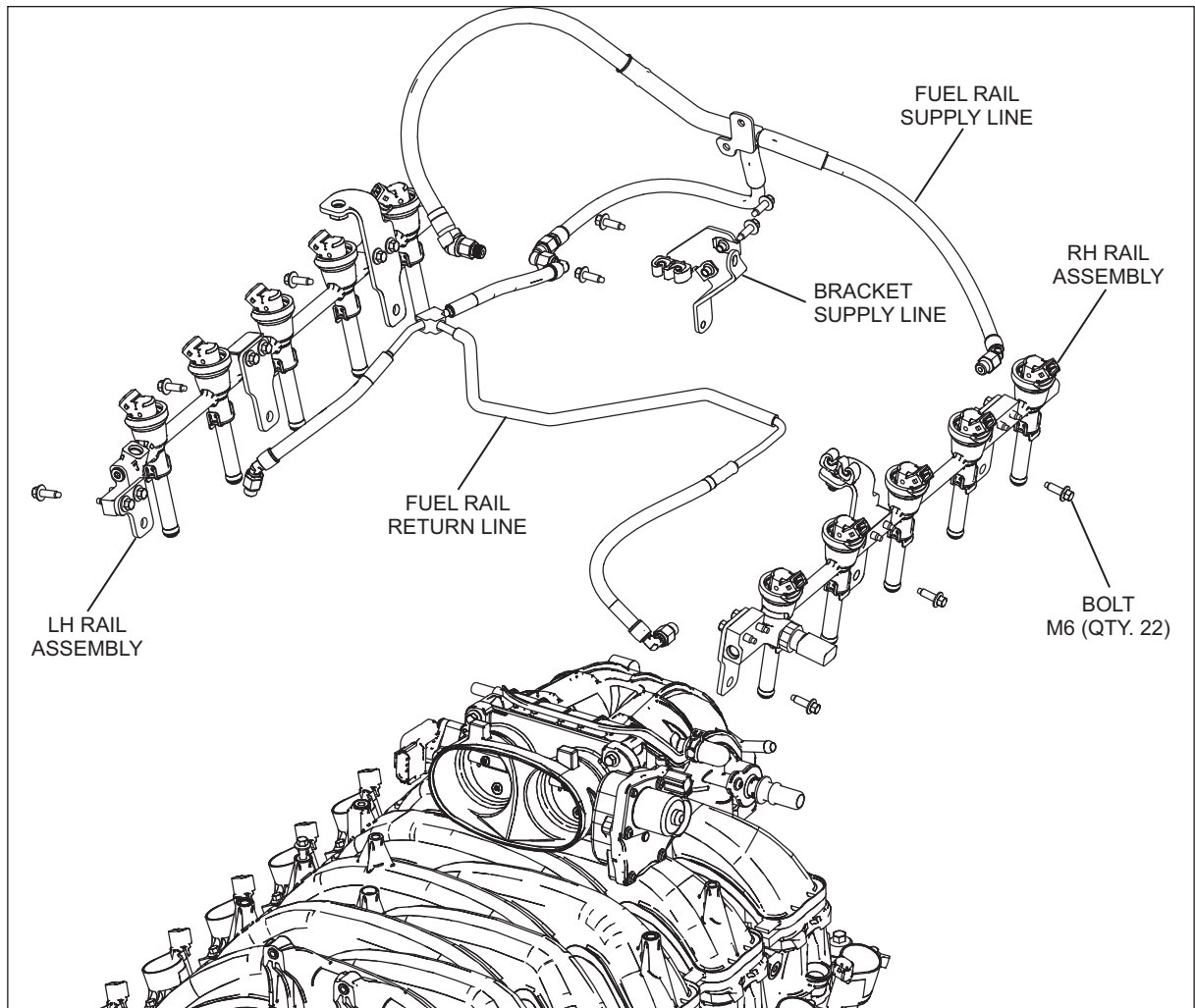

Figure 94 – Fuel Rail and Line Assembly

Fuel Injector

NOTE

It is possible to service the injector on the vehicle. However, clean the area thoroughly and blow the area clean with compressed air before starting.

⚠ CAUTION

When removing or replacing any fuel delivery components which include: fuel rails, injectors, or supply lines, thoroughly clean the work area with solvents and compressed air to remove any debris or contaminants. Always insure your hands are clean when handling fuel injection components to prevent contaminating the fuel delivery systems.

If replacing one or more injectors, use the following procedure.

Removal

1. Purge the fuel lines using the *Fuel Line Purging Procedure*.

⚠ CAUTION

Ensure the battery ground wires are disconnected before proceeding.

2. To release any residual propane in the lines, disconnect one of the fuel lines connected to the fuel rail. Once pressure is released, reconnect the line. Torque to: fuel rail supply line 23-26 Nm, fuel rail return line 20-22 Nm.
3. Disconnect the fuel injector electrical connector.
4. Remove the fuel injector retention C-clip.

- Using a twisting motion, pull the fuel injector straight upward out of the fuel rail (a pair of pliers might be necessary to help remove the fuel injector). Use care to prevent damage to the fuel injector.
- Repeat steps 2-5 as needed for the remaining fuel injectors.

Replacement**NOTE**

Before removing the injector assembly from the package, clean the work area and your hands. Do not remove the protective caps until it is necessary.

- Lubricate the upper and lower injector O-rings using SAE 5W20 motor oil or equivalent.
- Install the fuel injector into the fuel rail, so that the electrical connection faces away from the intake manifold when the injector is fully seated. Place the injector in position, then push straight down to ensure it is fully seated.
- Install the fuel injector retention C-clip and ensure it is fully engaged in the groove.
- Connect the fuel injector electrical connector.
- Repeat steps 1-4 as needed for the remaining fuel injectors.
- Connect the vehicle batteries.
- Perform the *Fuel System Priming Procedure*.
- Check the fuel line and rail connections for leaks using an electronic leak detector or leak detection solution.

Injection Pressure Temperature Sensor**Removal**

- Disconnect the vehicle battery and refer to the *Fuel Line Purging Procedure*.
- Once the system is properly drained, remove the connector from the IPTS and remove the sensor from the fuel rail.

Replacement

- Install the new IPTS into the fuel rail assembly and torque to 7 +/-1 Nm.
- Reinstall connector to the IPTS.
- Perform the fuel system priming procedure and ensure there are no leaks present from the fuel system.
- Reconnect vehicle battery and clear all DTCs.



Figure 95 – Injection Pressure Temperature Sensor

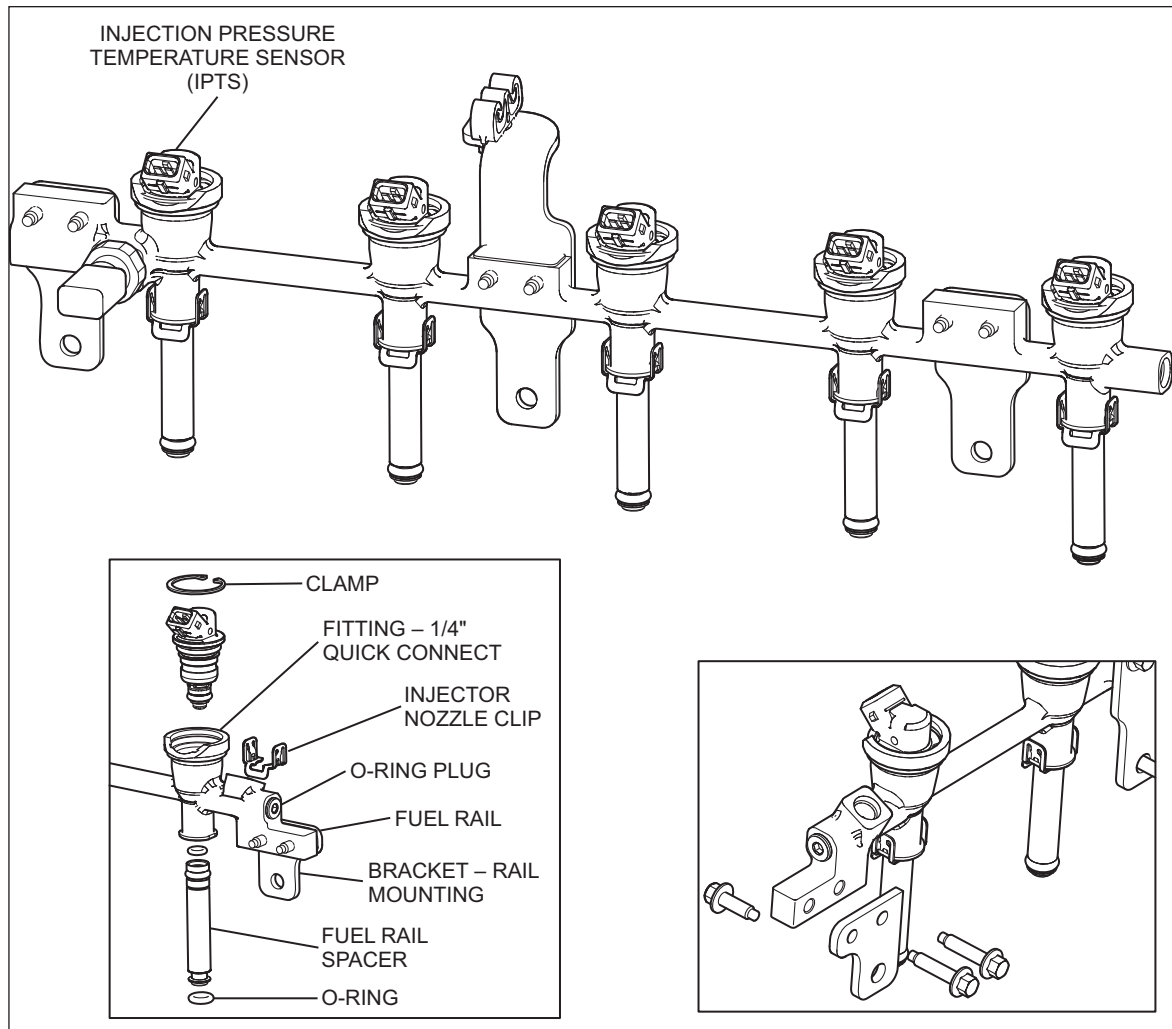

Figure 96 – Fuel Rail Assembly Detail

Smart Relay Module

The LPA fuel system includes a SRM. The SRM, also referred to as the Gateway module, serves several functions:

- Reads IPTS and transmits values to the PCM.
- Reads fuel level sender and broadcasts the value to the instrument cluster and the PCM.
- Monitors the second fuel pump monitor line and transmits the status to the PCM.
- Receives solenoid state commands from the PCM and opens and closes the solenoids accordingly.

Removal

NOTE

The SRM assembly is mounted to the cooling reservoir bracketry on the passenger side of the engine compartment on F-650/F750 vehicles. The SRM is mounted above the engine on the body near the brake booster on F-59. Replacement is similar on all platforms.

1. Disconnect the negative battery cable from the battery.
2. Disconnect the main harness connector at the SRM.

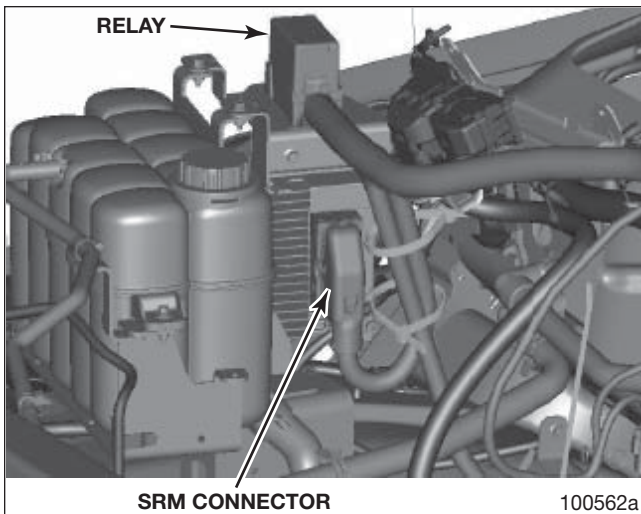

Figure 97 – Disconnect Main Harness Connector

CAUTION

Do NOT pry on the locking lever or damage can occur. If the lever does not move freely, push in on the top of the connector to reduce the load.

3. Remove the socket head cap bolt from the upper right side of the SRM bracket and remove the ground eyelet from the bracket.

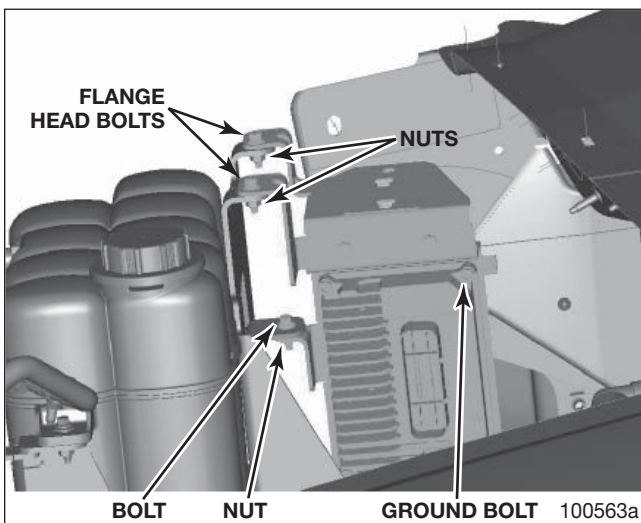

Figure 98 – SRM Bracket Mounting

4. Remove the two M6x16 flange head bolts from the upper part of the SRM bracket-to-cooling reservoir bracket.
5. Remove the M6x16 bolt and M6 nut from the lower part of the SRM bracket-to-cooling reservoir bracket.

6. Remove the SRM and bracket together as an assembly from the vehicle.
7. Remove the two bolts and nuts and remove the SRM and bracket from the cooling bracketry.

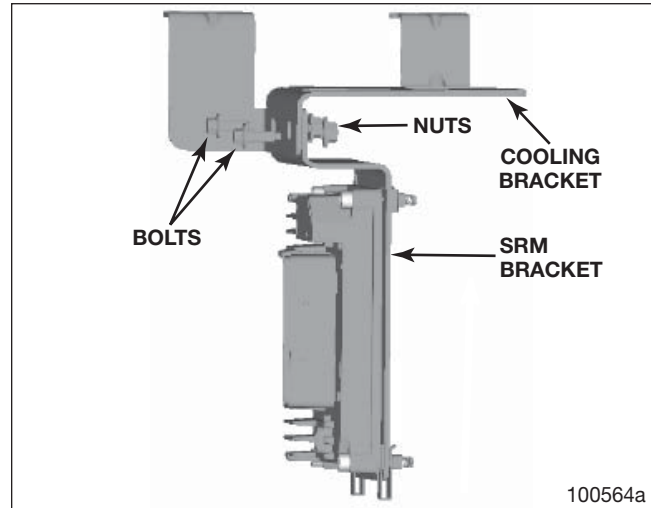

Figure 99 – SRM Bracketry

8. Remove the M6x35 socket head cap bolts from the SRM. Remove the SRM from the bracket.

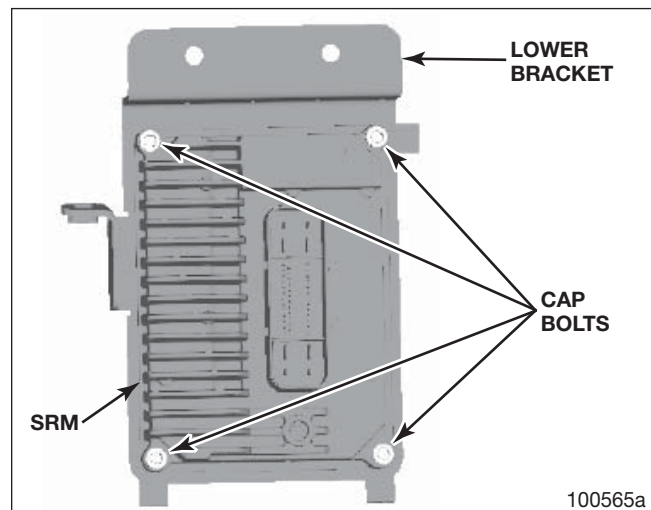

Figure 100 – SRM

Installation

1. Position the SRM on the mounting bracket. Secure the SRM to the bracket using three M6x35 socket head cap bolts. The upper right hand bolt will be used to secure the ground eyelet later. Torque to 5-7 Nm. Figure 100.
2. Place the SRM and bracket into the mounting position on the cooling reservoir bracketry.

3. Install two M6x16 flange head bolts to attach the upper part of the SRM bracket to the cooling reservoir bracketry. Torque to 8-12 Nm. Figure 99.
4. Install the M6x16 bolt and M6 nut to attach the lower part of the SRM bracket to the cooling bracketry. Torque to 8-12 Nm. Figure 98.
5. Install the upper right-hand M6x35 socket head cap bolt with the ground eyelet. Torque to 5-7 Nm.
6. Connect the main harness connector to the SRM. Figure 97.
7. Reconnect the negative battery cable.

Tank Pressure Temperature Sensor

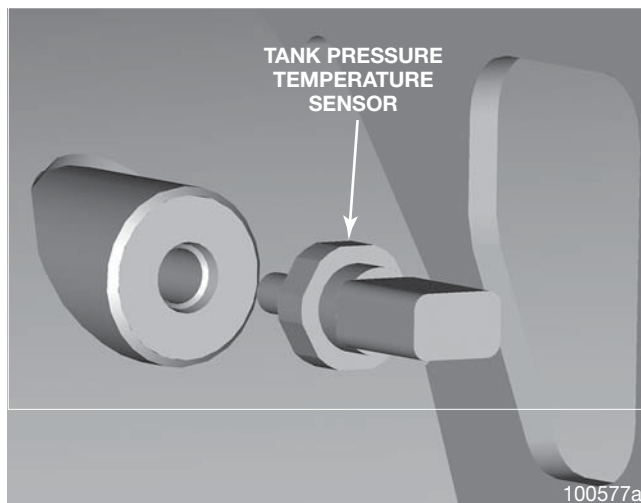

Figure 101 – Tank Pressure Temperature Sensor

Removal

1. Disconnect the vehicle battery and refer to *Fuel Tank Evacuation Procedure*.
2. Once the tank is properly drained, remove the connector from the TPTS and remove the sensor from the fuel tank.

Replacement

1. Install the new TPTS into the fuel tank assembly and torque to 7 +/-1 Nm.
2. Reinstall the connector to the TPTS.
3. Perform the *Fuel Tank Purge Procedure* and ensure there are no leaks present from the fuel tank assembly.
4. Reconnect vehicle battery and clear all DTCs.

PREPARING VEHICLE FOR USE AFTER SERVICE

Operating the Manual Shutoff Valve

1. After fuel system service is complete, open the manual shutoff valve on the tank by turning it counterclockwise until it stops.

NOTE

The manual shutoff valve can be hard to turn. From fully open to fully closed is approximately 3-1/2 turns.

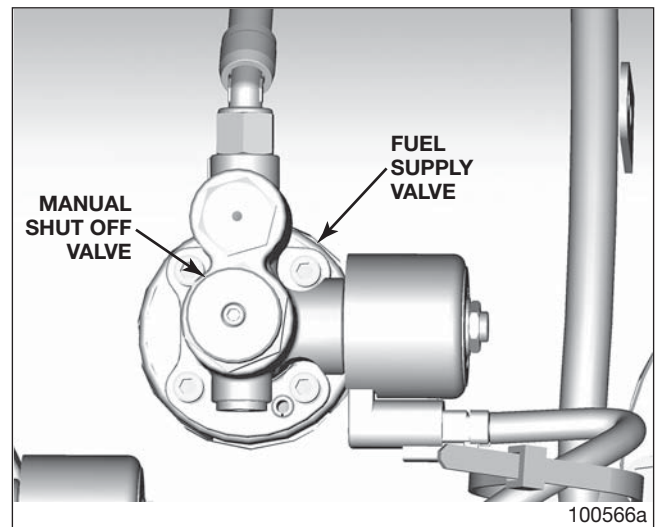

Figure 102 – Manual Shutoff Valve
(Typical, Under Vehicle Tank Shown)

2. Follow the *Fuel Tank Purging Procedure* and the *Fuel Delivery System Priming Procedure* in this section.
3. Leak check the fuel lines and fuel rails with an electronic leak detector or leak detection solution. Repair as necessary.
4. Install the tank cover plate onto the tank. Refer to *Tank Cover Plate* for more information.
5. Start and run the engine and check for diagnostic trouble codes. Repair as necessary.

NOTE

Starting the engine for the first time after the fuel supply line has been evacuated may cause the excess flow valve to close, which may cause the engine to run rough or stall. If this occurs, turn off the ignition and wait about 30 seconds, then restart. This may have to be repeated multiple times until the fuel supply line comes up to pressure.

For any questions, please contact ROUSH CleanTech Customer Service at 800-59-ROUSH (597-6874).

Fuel Tank Purging Procedure

The following procedure is required to purge the air from the fuel tank after servicing.

1. Fill the tank with one gallon of propane and cycle the ignition key to the crank position and then to the off position. (Do not allow the vehicle to start during this step.)
2. Inspect and monitor the tank for any leaks.
3. Open the bleeder valve for 20 minutes or until propane stops bleeding, whichever comes first. Close the bleeder valve.
4. Fill with 25+ gallons of propane.
5. Close the bleeder valve.

NOTE

When filling an empty tank, start filling at a slow rate to build up pressure inside the tank. An initial fast fill may trip the OPD, creating a slow or no fill condition.

6. Perform a final leak inspection at all fuel fill and fuel line connections to ensure no leaks are present using an electronic leak detector or leak detection solution.
7. Install the supply circuit cover on the tank. Apply anti-seize to the thumb screws and hand tighten.

Fuel System Priming Procedure

After performing any fuel system service work, air will have entered the system through the open connections and ports. You will need to prime the fuel system to expel all the air from the fuel lines and rails. To prime the fuel system, turn the ignition key to the Key On Engine Off (KOEO) position, NOT THE START POSITION.

See *Fuel System Description and Operation* at the beginning of this chapter for detailed operation of the purge cycle.

1. Make sure the battery is connected.
2. Check to make sure there is fuel in the tank and the manual shutoff valve is closed.
3. Turn the key to the KOEO position for 5 seconds.
4. Turn the key to the start position. When the "Start In Progress" light comes on, slowly open the manual shutoff valve.
5. If the vehicle does not start, close the manual shutoff valve and repeat the process.

Torque Chart

Fuel Tank and Vehicle Components		
Component	Quantity	Torque (Nm)
Remote Fill Valve	1	Hand Tight + 1/4 to 1/2 turn
Remote Pressure Relief Outlet	1	Hand Tight + 1/4 turn
Remote Bleeder Valve		Hand Tight + 1/4 to 1/2 turn
Fuel Fill Line	1	At Filter: 57 +/-4 At Valve: 45 +/-4
Fill Filter Clamp Bolt	1	23.0 +/-1.4
Bleeder Hose	1	18.5 +/-3.0
Fuel Tank Assembly	1	-----
Fuel Tank Line Bolts – M6	2	11 +/-1
Component	Quantity	Torque (Nm)
Pressure Relief Outlet	1	95 +/-5
Fuel Level Sender Screws – 1/4"	4	See Procedure
Bleeder Nozzle	1	20 +/- 4 MIN plus Orientation
Tank Access Cover Bolts – 3/8"	8	See Procedure
Fuel Filler – Tank OPD	1	P/N 66-1157B: • Valve 71-79 Nm MIN plus Orientation • 90-Degree Elbow 31-35 Nm MIN plus Orientation P/N A10110100: • Valve 100-108 Nm MIN plus Orientation • 90-Degree Elbow 51-55 Nm MIN plus Orientation
Fuel Return Circuit Screws – 1/4"	4	See Procedure
Fuel Supply Circuit Screws – 1/4"	4	See Procedure
Fuel Pump Housing to Tank Bolt – M5	1	5.8 +/-0.3
Fuel Pump Wiring Bolts - M4	3	2.7 +/-0.4
Fuel Pump Housing to Tank – M6 nuts	2	8.5 +/-0.5
Fuel Pump Housing – #6 Screw	4	0.56 +/-0.056
Pressure Relief Valve	1	213.5 Min.
Supply Circuit Cover – M5 Thumb Screw	4	Hand Tight
Fuel Rail and Line Assembly		
Component	Quantity	Torque (Nm)
Fuel Rail & Supply Line Bolts – M6	22	11 +/-1
O-Ring Plug	1	8.9 +/-0.9
Fitting – 1/4" and 3/8" Threaded	4	19 +/-1
Fuel Pressure and Temperature Sensor	1	7 +/-1

Evaporative System and Forward Fuel Components		
Component	Quantity	Torque (Nm)
Vapor Canister Bracket Bolts – Self Threading	3	2.75 +/-0.25
Vapor Canister Bracket Bolts – M6	2	6.0 +/-0.3
Vapor Canister to Frame Fasteners – M10	4	65.0 +/-13.3
Smart Relay Module Bolt – 1/4"	4	11.5 +/-0.5
FRPCM Bracket Assembly Bolts		
M6 Bolts	2	10 +/-2
M8 Bolt	1	25 +/-5
Bleeder Port	1	19 +/-1
FRPCM Line Fittings		
Forward Return Line	1	18-20
Engine Supply Line	1	23-26
Forward Supply Line	1	29-33
Engine Return Line	1	20-22

TOOLS AND EQUIPMENT

Special Tools

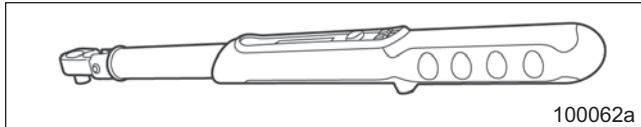

Figure 103 – Torque Wrench (2 required, 22 Nm and 200 Nm)

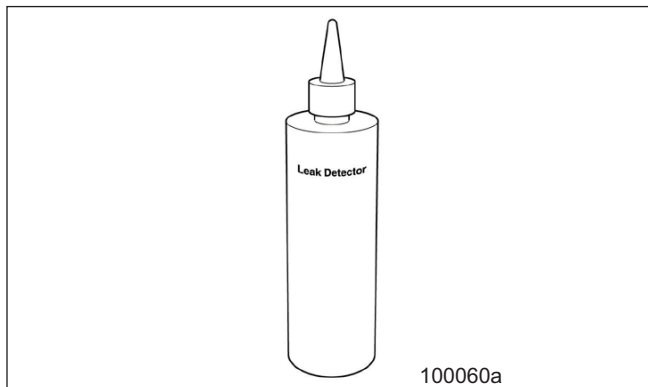

Figure 104 – Liquid Leak Detector

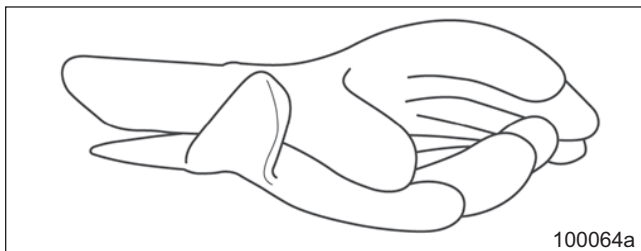

Figure 105 – Gloves (Approved for propane)

Quick Disconnect Tools

The fuel lines in the LPA system use quick connect fittings, which require special tools to disconnect the supply lines. The supply lines use the 3/8” tool which can be purchased from any automotive service tool supplier.



Figure 106 – Quick Disconnect Tools

Electronic Leak Detector

If purchasing an electronic leak detector, it is recommended to use a tester capable of detecting down to 35 PPM of propane vapor.

Flare Tower

A flare stand/tower can be used to burn off vented propane during servicing. If using a flare tower we recommend purchasing one from a reputable supplier, such as:

www.flameengineering.com/Propane_Flare.htm



Do not attempt to build your own flare tower. Failure to exercise extreme caution and care may lead to serious accidents which can result in property damage, personal injury and/or death.



Some states and municipalities may have regulations preventing the release of LPG into the atmosphere. Check with your local fire marshal or your local LPG supplier prior to venting or burning off a tank.

©2016 by ROUSH CleanTech. All rights reserved.

The information in this publication was accurate and effective at the time the publication was approved for printing and is subject to change without notice or liability. ROUSH CleanTech reserves the right to revise the information herein and to make changes and discontinue production of described parts at any time.